



SECTION III: NOTICE INVITING BID

	<p>RAJASTHAN STATE ROAD TRANSPORT CORPORATION OFFICE OF THE GENERAL MANAGER (B/B) HEAD OFFICE, JAIPUR TEL No. 0141-2374672 Email:-rsrtc.edeng@gmail.com</p>
--	--

NIB NO. RSRTC/ED(Engg.)/Bus Body/2024-25/657 Date: 16.12.24

Fabrication of bus bodies for BS VI 3x2 Super Express Blue Line bus with Passenger seats

S. No	Group of item	Eligibility for firms	Estimated value of Bus body fabrication. Rs. (in lacs)	Estimated quantity	Cost of bid documents (non-refundable) Rs.	Bid processing fee Rs. (non-refundable)	Bid Security for financial bid in Rs. (in lacs)	Pre-bid meeting date
								Last date of bid submission
								Opening date of Technical bid
1	Fabrication of BS VI 3x2 Super Express Blue Line bus bodies with passenger seats	Bus Body fabricator who have valid and latest bus code accreditation certificate as per AIS052 and CMVR regulation or prevailing latest bus body code at the time of fabrication	3456	288	59000	2500	69.12	30.12.2024 12.00 Hrs
								05.02.2025 17.00 Hrs
								07.02.2025 11.00 Hrs

If any holiday comes on above dates then next working date will be treated for the same. For bidding process bidder shall obtain the user ID and password for participating in e-bidding system through website <https://eproc.rajasthan.gov.in> or from e-procurement cell RISL, Yojana Bhawan, Tilak Marg, C- Scheme, Jaipur and contact on (Help Desk be contacted directly in the following mobile nos. 0120-4200462, 0120-4001002 , 91-8826246593. 10.00 AM to 06.00 PM on all working days)& also local no. 0141-4022688 working hour Monday to Friday 9.30 AM to 06.00 PM on all working days.The help desk can also be reached by mail support-eproc@nic.in.

NOTE:-

- The detailed notification/bid documents can be downloaded from website <https://eproc.rajasthan.gov.in> & <https://sppp.rajasthan.gov.in> Details of this bid notification and pre-qualification criteria can also be seen in NIB exhibited on website <https://transport.rajasthan.gov.in/rsrtc> & <https://sppp.rajasthan.gov.in> Bids are to be submitted online in electronic format on website <https://eproc.rajasthan.gov.in>.



2. Corrigendum's/modifications/corrections if any, will be published on the website- <https://eproc.rajasthan.gov.in>, <https://transport.rajasthan.gov.in/rsrtc> & <https://sppp.rajasthan.gov.in>
3. Conditional / incomplete bid will be rejected.
4. Bidders who wish to participate in this bid will have to register on <https://eproc.rajasthan.gov.in>, before request of documents. To participate in online bids Bidders will have to procure digital signature certificate (type II or type III) as per information technology Act-2000 using which they can sign their Electronic Bids. Bidders can procure the same from any CCA approved certifying agency i.e. TCS safe crypt, Ncode etc. or they may contact e-procurement cell, Department of IT & C, government of Rajasthan for further assistance. Bidders who already have a valid Digital Certificate need not procure a new Digital Certificate.
5. Bidders shall submit their offer (Technical & financial) online in Electronic formats both technical and financial proposal, however hard copy of Bid fee (Bid Documents Fee, Bid Processing fee and bid security) shall be submitted manually or through courier in the office of General Manager (B/B) RSRTC, Room no. 208, Head Office, Parivahan Marg, Jaipur-302001 before **one day before the day of opening of technical bid upto 05.00 PM**. Scanned copy of Demand Draft & other bid fees should also be uploaded along with the online bid.
6. RSRTC, reserves the right to accept or reject any or all the bids without assigning reasons thereof.
7. RSRTC reserves the right for verification of any information/ documents furnished by the bidder in the interest of the corporation.
8. Bid security in the shape of demand draft/Bank Guarantee payable to **FA RSRTC, Jaipur** (In case of BG it should be issued from branch of Scheduled bank) and Bid document fee in the shape of demand draft payable to **FA RSRTC, Jaipur** and Bid Processing fee in the shape of demand draft payable to **Managing Director RISL, Jaipur** should be submitted before opening of technical bid.
9. Before electronically submitting the bid it should be ensured that all the documents including conditions of contract are digitally signed by the bidder.
10. Training for the Bidders on the usage of e-bidding system is also being arranged by RISL on regular basis. Bidders interested on training may contact e-procurement cell RISL for booking the training slot.
11. Bidders are also advised to refer "Bidders manual" available under "downloads" section for further details about the e-bidding process.

Bid documents can be downloaded from online website <https://eproc.rajasthan.gov.in>

For further details bidder may visit online website <https://eproc.rajasthan.gov.in> or from e-procurement cell RISL, Yojana Bhawan, Tilak Marg, C- Scheme, Jaipur-302005 and contact on (Help Desk be contacted directly in the following mobile nos. **0120-4200462, 0120-4001002, 91-8826246593**. 10.00 AM to 06.00 PM on all working days) & **also local no. 0141-4022688 working hr. Monday to Friday 9.30 AM to 06.00 PM** on all working days. The help desk can also be reached by mail support-eproc@nic.in.

GENERAL MANAGER (B/B)



GENERAL MANAGER (B/B)

RAJASTHAN STATE ROAD TRANSPORT CORPORATION,

HEAD – OFFICE, PARIVAHAN MARG,

JAIPUR – 302001

TELEPHONE NO. 0141 – 2374672

Email-rsrtc.edeng@gmail.com

**BID DOCUMENT FOR FABRICATION OF BUS BODIES FOR
BS VI 3x2 SUPER EXPRESS BLUE LINE BUSES WITH PASSENGER SEATS
FOR 2024-25
OPEN COMPETITIVE BIDDING**



S. no.	Section	Description of contents	Page No.
1	I	Definitions	3-4
2	II	Important Dates and Timeline	5
3	III	Notice Inviting Bid	6-7
4	IV	Introduction And Scope of Work	8
5	V	Instructions to Bidders	9-11
6	VI	Qualification and Evaluation Criteria	12-14
7	VII	Bidding Process	15-17
8	VIII	Bid Specifications	18-28
9	IX	General Terms and Conditions of contract	29-41
10	X	Various Annexures	42-63
		ANNEXURE "A" Technical bid application	42
		ANNEXURE 'B' Declaration by the Bidder	43
		ANNEXURE "C" Compliance with the code of integrity and No conflict of interest	44
		ANNEXURE "D" Bid Security format in case of Bank Guarantee	45
		Annexure "E" Grievance redressal during procurement process:	46-47
		FORM No. 1 [See rule 83] Appeal under the Rajasthan Transparency in Public Procurement Act, 2012	48
		Annexure "F" Additional Condition of Contract	49
		ANNEXURE "G" Format of Bank Guarantee for 10% Performance Security	50
		ANNEXURE "H" Authority Letter	51
		ANNEXURE - "I" Details of bidder organizational set up & addresses of factory	52-53
		ANNEXURE - "J" Financial turnover status	54
		ANNEXURE-"K" Factory area and plant & machinery	55-56
		ANNEXURE -'L' Working experience & production capacity	57
		ANEXXURE -"M" Information regarding litigation/ debaring/ Expelling of bid	58
		ANNEXURE-"N" Joint venture data	59
		ANNEXURE-"O" AFFIDAVIT (To be given separately by each partner of joint venture)	60
		ANNEXURE-"P"Declaration by the Bidder regarding Qualifications	61
		ANNEXURE "Q" Financial parameter sheet	62
		ANNEXURE "R" Trust bond receipt	63
11	XI	Check List	64
12		Drawings	65-75



SECTION-I DEFINITIONS

S.no.	Defined Term	Meaning
1.	ASRTU	Association of State Road Transport Undertaking
2.	Bid	A formal offer made by the Bidder in pursuance of the Invitation to Bid comprising of the Technical Bid and Financial Bid.
3.	Bid Document	This Bid document issued by RSRTC including the Invitation to Bid, any amendments thereto that set out the terms and conditions of the Bidding Process.
4.	Bid Document Fees	Fee payable by the Bidder through demand draft (DD) only, to purchase the Bid Document.
5.	Bid Processing Fees	Fee payable by the Bidder through demand draft (DD) only, for processing of the Bid Document.
6.	Bid Security Deposit	An interest free security deposit provided to RSRTC by a Bidder for securing the fulfilment of obligations in terms of the Bid Document.
7.	Bidder	Any firm participating in the Bidding Process.
8.	Bidding Process	The process of Bidding starting from the issuance of Invitation to Bid till acceptance of the Bid or cancellation of the Bidding Process, as the case may be.
9.	BOQ	Bill of Quantity
10.	CIRT	Central Institute of Road Transport
11.	LOA	Letter of Acceptance
12.	LOI	Letter of Intent
13.	ROC	Registrar of Companies
14.	RSRTC	Rajasthan State Road Transport Corporation
15.	RTPP Act 2012	Rajasthan Transparency in Public Procurement Act, 2012
16.	RTPP Rules 2013	Rajasthan Transparency in Public Procurement Rules, 2013
17.	Successful Bidder	The Bidder whose Bid accepted by RSRTC in terms of the Bid Document.
18.	Fee Documents	Comprises of Bid Document Fee, bid processing fee in shape of DD and Bid Security deposit in shape of DD/ BG required to be submitted in accordance with this Bid Document.
19.	Technical Bid	Comprises of all the documents and annexures required to be submitted in accordance with this Bid Document.
20.	Financial Bid	Comprises of Bill of Quantity (BOQ) required to be submitted in accordance with this Bid Document.
21.	FOC	Free of charge
22.	STU	State Transport Undertaking
23.	PSU	Public Sector Undertaking
24.	PDI	Pre-Delivery Inspection



S.no.	Defined Term	Meaning
25.	ITB	Instruction to Bidder
26.	AIS	Automotive Industry Standards
27.	FES	Front End Structure
28.	JV	Joint Venture
29.	OEM	Original Equipment Manufacturer
30.	NABL	National Accreditation Board For testing & Calibration Laboratories
31.	EPDM	Ethylene Propylene Diene Monomer
32.	NIB	Notice Inviting Bid



SECTION II: IMPORTANT DATES AND TIMELINE

S. No.	Particulars	Date
1.	Bid Publish Date	17.12.2024
2.	Pre-Bid conference Date & Time	24.12.2024, 12.00 Hrs
3.	Bid Submission Start Date	24.01.2025, 17.00 Hrs
4.	Bid Submission End Date	05.02.2025, 17.00 Hrs
5.	Date and time of opening of Technical Bid	07.02.2025, 11.00 Hrs

NOTE:

1. The Technical Evaluation Committee or other committee may visit the Bidder's premises, if required.
2. On receiving the Evaluation Committee's report, the Financial Bids of only technically qualified Bidders shall be opened.
3. The rights to accept or reject any or all the Bids without assigning any reasons thereof are reserved with RSRTC.
4. Sealed envelope consisting of bid fee, processing fee and bid security is to be submitted to undersigned office **one day before the day of opening of technical bid upto 05.00 PM.**

-Sd/-
General Manager (B/B)
Rajasthan State Road Transport Corporation



SECTION III: NOTICE INVITING BID

	<p>RAJASTHAN STATE ROAD TRANSPORT CORPORATION OFFICE OF THE GENERAL MANAGER (B/B) HEAD OFFICE, JAIPUR TEL No. 0141-2374672 Email:-rsrtc.edeng@gmail.com</p>
---	--

NIB NO. RSRTC/ED(Engg.)/Bus Body/2024-25/

Date:

Fabrication of bus bodies for BS VI 3x2 Super Express Blue Line bus with Passenger seats

S. No	Group of item	Eligibility for firms	Estimated value of Bus body fabrication. Rs. (in lacs)	Estimated quantity	Cost of bid documents (non-refundable) Rs.	Bid process ing fee Rs. (non-refundable)	Bid Security for financial bid in Rs. (in lacs)	Pre-bid meeting date
								Last date of bid submission
								Opening date of Technical bid
1	Fabrication of BS VI 3x2 Super Express Blue Line bus bodies with passenger seats	Bus Body fabricator who have valid and latest bus code accreditation as per AIS052 and CMVR regulation or prevailing latest bus body code at the time of fabrication	3456	288	59000	2500	69.12	30.12.2024 12.00 Hrs
								05.02.2025 17.00 Hrs
								07.02.2025 11.00 Hrs

If any holiday comes on above dates then next working date will be treated for the same. For bidding process bidder shall obtain the user ID and password for participating in e-bidding system through website <https://eproc.rajasthan.gov.in> or from e-procurement cell RISL, Yojana Bhawan, Tilak Marg, C- Scheme, Jaipur and contact on (Help Desk be contacted directly in the following mobile nos. 0120-4200462, 0120-4001002, 91-8826246593. 10.00 AM to 06.00 PM on all working days)& also local no. 0141-4022688 working hour Monday to Friday 9.30 AM to 06.00 PM on all working days. The help desk can also be reached by mail support-eproc@nic.in



NOTE:-

1. The detailed notification/bid documents can be downloaded from website <https://eproc.rajasthan.gov.in> & <https://sppp.rajasthan.gov.in> Details of this bid notification and pre-qualification criteria can also be seen in NIB exhibited on website <https://transport.rajasthan.gov.in/rsrtc> & <https://sppp.rajasthan.gov.in> Bids are to be submitted online in electronic format on website <https://eproc.rajasthan.gov.in>.
2. Corrigendum's/modifications/corrections if any, will be published on the website- <https://eproc.rajasthan.gov.in>, <https://transport.rajasthan.gov.in/rsrtc> & <https://sppp.rajasthan.gov.in>
3. Conditional / incomplete bid will be rejected.
4. Bidders who wish to participate in this bid will have to register on <https://eproc.rajasthan.gov.in>, before request of documents. To participate in online bids Bidders will have to procure digital signature certificate (type II or type III) as per information technology Act-2000 using which they can sign their Electronic Bids. Bidders can procure the same from any CCA approved certifying agency i.e. TCS safe crypt, Ncode etc. or they may contact e-procurement cell, Department of IT & C, government of Rajasthan for further assistance. Bidders who already have a valid Digital Certificate need not procure a new Digital Certificate.
5. Bidders shall submit their offer (Technical & financial) online in Electronic formats both technical and financial proposal, however hard copy of Bid fee (Bid Documents Fee, Bid Processing fee and bid security) shall be submitted manually or through courier in the office of General Manager (B/B) RSRTC, Room no. 208, Head Office, Parivahan Marg, Jaipur-302001 before **one day before the day of opening of technical bid upto 05.00 PM**. Scanned copy of Demand Draft & other bid fees should also be uploaded along with the online bid.
6. RSRTC, reserves the right to accept or reject any or all the bids without assigning reasons thereof.
7. RSRTC reserves the right for verification of any information/ documents furnished by the bidder in the interest of the corporation.
8. Bid security in the shape of demand draft/Bank Guarantee payable to **FA RSRTC, Jaipur** (In case of BG it should be issued from branch of Scheduled bank) and Bid document fee in the shape of demand draft payable to **FA RSRTC, Jaipur** and Bid Processing fee in the shape of demand draft payable to **Managing Director RISL, Jaipur** should be submitted before opening of technical bid.
9. Before electronically submitting the bid it should be ensured that all the documents including conditions of contract are digitally signed by the bidder.
10. Training for the Bidders on the usage of e-bidding system is also being arranged by RISL on regular basis. Bidders interested on training may contact e-procurement cell RISL for booking the training slot.
11. Bidders are also advised to refer "Bidders manual" available under "downloads" section for further details about the e-bidding process.

Bid documents can be downloaded from online website <https://eproc.rajasthan.gov.in>

For further details bidder may visit online website <https://eproc.rajasthan.gov.in> or from e-procurement cell RISL, Yojana Bhawan, Tilak Marg, C- Scheme, Jaipur-302005 and contact on (Help Desk be contacted directly in the following mobile nos. **0120-4200462, 0120-4001002, 91-8826246593**. 10.00 AM to 06.00 PM on all working days) & **also local no. 0141-4022688 working hr. Monday to Friday 9.30 AM to 06.00 PM** on all working days. The help desk can also be reached by mail support-eproc@nic.in.

GENERAL MANAGER (B/B)



SECTION IV: INTRODUCTION & SCOPE OF WORK

Rajasthan State Road Transport Corporation has been established on 1st October 1964 under the Road Transport Act 1950 with the objective of providing economic, adequate, punctual and efficient services to the travelling public in the state. Currently, almost 3600 buses across 52 depots are plying approx. 13 lacs kilometers and carrying approx. 7.5 lac passengers per day.

RSRTC is committed to provide high quality services, consistently and constantly improving the services for the satisfaction of the passengers. To fulfill the commitment, RSRTC has incorporated Ordinary, Express, Deluxe, A.C., A.C. Sleeper and various models of Super Luxury Buses in its fleet for all categories of passengers.

RSRTC is inviting online bids from bus body makers, who have latest bus body code accreditation certificate as per AIS052 & CMVR (Revised or amended up to date) for FABRICATION OF 3x2 Super Express Blue Line PASSENGER BUSES of wheel base 5100mm to 5500 mm to Rajasthan State Road Transport Corporation (RSRTC) on the terms and conditions of this bid. The fabricator must provide all relevant certificates/ type approval which are necessary for registration of buses by transport department.



SECTION V: INSTRUCTIONS TO BIDDERS

The Law relating to procurement “RTPP Act 2012 & Rules 2013” under the said Act have come into force which are available on the website of State Public Procurement Portal <https://sppp.rajasthan.gov.in>. If there is any discrepancy between the provisions of the Act & the Rules and this Bidding Document, the provisions of the Act and the Rules shall prevail. Therefore, bidders are advised to acquaint themselves with the provisions of RTPP Act, 2012 and RTPP Rules, 2013 prior to bidding process.

1. This Bid is invited in Open Competitive bid system i.e. Technical Bid and Financial Bid. Both the Bids (Technical and Financial) have to be prepared and submitted online only by the Bidders.
2. The Bidder should ensure that the Bid is submitted as per stipulated timeline and not to wait till last moment to safeguard their own interest. RSRTC does not take any responsibility for non-submission of Bid due to any reason i.e. non-working of e-system/slow running of network etc. The Bidder should ensure that his hardware and software is compatible to the online system.
3. RSRTC shall not take the responsibility for any delay in receipt of the Fee Documents which are to be submitted in original before opening of technical bid.
4. Each Bidder has to submit the ‘Technical Bid’ and ‘Financial Bid’ separately on the e-proc portal as per the instructions given in this Bid Documents.
5. Breach of this Bid Document and/or RTPP Act 2012 and/or RTPP Rules 2013 as on the date of the submission of this Bid will render the Bidder ineligible to continue in the Bidding process.
6. The Bidder must ensure that no conflict of interest subsists or occurs as a result of submission of its Bid pursuant to this Bid Document.
7. Those Bidders who will qualify as per the qualification criteria for the Technical Bid, only their Financial Bids will be opened.
8. The Bidder shall not quote its offer/commercials directly or indirectly in the Technical Bid, failing which the Financial Bid may not be opened and its Bid may be rejected.
9. RSRTC at its sole discretion and without assigning any reasons there of reserves the right to accept or reject any/all Bids at any stage.
10. The Bidder shall bear all costs associated with the preparation and submission of its Bid and RSRTC will in no case be responsible or liable for these costs, regardless of the conduct or outcome of the Bidding process.
11. Bids containing deviations from Bid Document, terms and other requirements (i.e. conditional bids) are liable to be rejected.
12. This Bid Document incorporates all the general instructions, standard terms and conditions of contract, all annexures, schedule of rates i.e. BOQ, Bid-fees, bid security and other correspondence related to this Bidding process.
13. The Bidders are requested to read all instructions, forms, terms and conditions, specifications and other information mentioned in the bid documents carefully.
14. The Bidder must provide all information and data during this Bidding process, in a manner that is true, correct, accurate and complete and no such information, data or statement provided by the Bidder is inaccurate or misleading in any manner.
15. Failure to furnish all information required or submission of Bid not substantially responsive to the Bid Document in every respect will be at the Bidder’s risk and may result in rejection of Bid.
16. Every term shall be mentioned in proper detail and shall be no ambiguity in term in the Bidder’s response to the Bid.
17. **Pre- Bid Conference:** The bidder or his authorized representative is invited to attend the pre-bid conference as per the date and time mentioned in the NIB. The purpose of Pre-Bid conference is to clarify issue and to answer question on any matter related to this procurement process that may be raised at that stage. However, RSRTC reserve the right to either provide or deny providing any clarifications to any of the queries of the Bidders without assigning any reasons whatsoever.



18. RSRTC reserves the right to also make correction/addition/deletion in the Bid Document and accordingly corrigendum will be issued by the RSRTC and same will be available on the <https://eproc.rajasthan.gov.in>, <https://sppp.rajasthan.gov.in> <https://transport.rajasthan.gov.in/rsrtc> portals. Corrigendum, if any issued by RSRTC shall form part of the Bid.
19. Bidder is requested to follow e-tendering instructions and submit their Bid as per the instructions. No complaint or request in this regard will be entertained.
20. Each page of the Bid documents submitted by the Bidder should be duly Stamped & signed by the authorized signatory of the Bidder while uploading the bid on the e-proc portal.
21. This Bid Document shall be governed and interpreted according to the **Laws of India**.
22. **Acceptance of the successful Bid and Issuance of Letter of Intent:**
- (i) The Work order will be placed by RSRTC as per the quoted rates/ finalized rates thereafter, to the Successful Bidder in the Financial Bid.
 - (ii) If the issuance of work order is likely to take time, in the meanwhile a Letter of Intent (LOI) / Letter of Acceptance (LOA) may be sent to the successful Bidder for supply as a token of acceptance of bid.
23. **Signing of contract/agreement and award of contract:**
- (i) Pursuant to the Successful Bidder being notified that its Bid has been accepted by RSRTC, the successful Bidder and RSRTC shall enter into a written contract for fabrication of buses on a non-judicial stamp of Rs 500 within 15 days of issuance of LOI/LOA to the Successful Bidder.
 - (ii) Any cost required to be incurred for such Procurement Contract will be borne by the Successful Bidder including the applicable stamp duty etc.
 - (iii) Until the execution of the Procurement Contract, the terms and conditions of the LOI/LOA/ work order/ Bid documents shall prevail.
24. **Validity of Bid:** The submitted Bid must be valid for 90 days from the last date of submission of Bid (“Validity Period”). The Bidder shall not be entitled, during the Validity Period, to revoke its Bid or cancel the offer or to vary any terms thereof. In case of the Bidder revoking its Bid or cancelling the offer or varying any terms in regards thereof during the Validity Period, the Bid Security Deposit of such Bidder will be forfeited.
25. **Bid security deposit:**
- A. The Bidder shall submit the bid security deposit in accordance with the following conditions:
- i) Bid Security shall be 2% of the estimated value of subject matter of procurement as mentioned in the NIB.
 - ii) In case of Small-Scale Industries of *Rajasthan*, it shall be 0.50% of the estimated value of the bid.
 - iii) Bid Security of a Bidder lying with the RSRTC in respect of other Bids awaiting decision shall not be adjusted towards the Bid Security of this Bid. The Bid Security originally deposited may, however, be taken into consideration in case Bids are re-invited.
 - iv) The Bid Security may be given in the form of demand draft or bank guarantee [to be confirmed by bank], in specified format, and issued from Rajasthan based branch of Scheduled Bank and must be valid till at-least 120 days from the last date of bid submission. Bank guarantee issued from the branch of a bank operational outside Rajasthan state, will not be acceptable. Also, it must be assured that the Bank guarantee must be issued from the Bank account of participating Bidder only.
 - v) The Bid Security of unsuccessful Bidders be refunded soon after final acceptance of the successful Bid, signing of agreement and pursuant to submission of Performance Security.



- vi) RSRTC shall return the bid security after the earliest of the following events, namely-
 1. The expiry of validity of bid security
 2. The execution of agreement for procurement and performance security is furnished by the successful bidder.
 3. The cancellation of the procurement process; or
 4. The withdrawal of bid prior to the deadline for presenting bids, unless the bidding documents stipulate that no such withdrawal is permitted.
- vii) No interest will be paid by the RSRTC on the amount of Bid Security.

B. The Bid Security taken from a Bidder shall be forfeited in the following cases, namely:

- i) when the Bidder withdraws or modifies his Bid after opening of Bids; or
- ii) when the Bidder does not execute the work order/agreement within specified time period; after issue of letter of acceptance/placement of supply order; or
- iii) when the Bidder fails to commence the supply of the Goods or Related Services as per supply order within the time specified; or when the bidders fails to make complete supply of acceptable goods.
- iv) when the Bidder does not deposit the performance Security in the specified time after the supply/work period order is placed; or
- v) If the Bidder breaches any provision of the Code of Integrity prescribed for Bidders specified in the Act, Chapter VI of the RTPP Rules,2013.

C. In case of the successful Bidder, the amount of Bid Security in the shape of DD may be adjusted in arriving at the amount of the Performance Security, or refunded if the successful Bidder furnishes the full amount of Performance Security.

26. Bid document fee and processing fee:

- i. The bid documents fees Rs. 50000/- with 18% GST Extra (i.e. Rs. 59000/-) to be paid in the form of Demand Draft in favor of **FA RSRTC JAIPUR.**
- ii. The bid processing fees Rs. 2500/- to be paid in the form of Demand Draft in favor of **Managing Director RISL Jaipur.**

27. Language:

- i. The work order/contract as well as all correspondence and documents related to the Contract exchanged by the Bus body fabricaror and the RSRTC, shall be written in the English language.
- ii. If the bidder has submitted any required documents other than English language, then it will be the responsibility of the bidder to submit required documents in translated version while submitting the bid & bidder shall bear all costs of translation to the governing language and all risks of the accuracy of such translation..



SECTION VI: QUALIFICATION AND EVALUATION CRITERIA

The following criteria must be strictly fulfilled by the Bidder. The Bidder must submit documentary evidences in support of their claim for fulfilling the criteria. The Bids received without the documentary evidences are liable to be rejected. All the conditions mentioned below are mandatory to qualify the Bid. Non-compliance of any condition shall lead to non-responsiveness of the Bid.

Sr. No.	Basic Requirement	Specific Requirements	Documents Required
1.	Eligibility	Bidder should have Bus Body manufacturing plant who have latest bus code accreditation certificate AIS052 (revised or amended upto date) issued by ARAI, CIRT and any other testing agency approved as per CMVR Rule no. 126 by government of india for FABRICATION OF 3X2 SUPER EXPRESS BLUE LINE (Wheel Base 5100mm to 5500 mm) PASSENGER BUSES on TATA/LEYLAND/EICHER OR ANY OTHER SUITABLE CHASSIS. In case of joint venture, all members/ individuals or joint venture firm shall provide latest bus code accreditation certificate AIS052 (revised or amended upto date) issued by ARAI, CIRT and any other testing agency approved as per CMVR RULE No. 126 by government of india.	Copy of bus body accreditation certificate and type approval certificate for the bus body fabrication on chassis wheel base 5100 -5500 mm as per AIS052 of type II 3x2 layout .
2.	General Requirement/ Legal Entity	The bidder eligible for participating in the bidding process shall be a Company incorporated under the provisions of Indian Companies Act, 1956/2013 and/ or the firm may be Partnership/ Proprietary/ Joint venture. Bidder must be legally competent to enter into contract as per prevailing Indian laws.	Certificate of Incorporation/ Certificate of Registration issued by the Registrar of Companies is to be enclosed. In case of firm is in partnership/ proprietary/ Joint Venture, certified copy of the deed/GST/ MSME Aadhar no./Udhyog Aadhar/ Business reg. number is to be enclosed.



Sr. No.	Basic Requirement	Specific Requirements	Documents Required
3.	Turnover	The average annual turnover of the bidder, from the body fabrication during last three financial years (i.e. 2021-22, 2022-23, 2023-24) shall be 33.33% and above of the estimated cost of bus body fabrication mentioned in NIB.	1.Audited and Certified Balance Sheet for last three financial years (i.e. 2021-22, 2022-23, 2023-24) should be enclosed. 2.Profit-Loss Account or Turnover certificate for last three financial years (2021-22, 2022-23, 2023-24) duly certified by the CA should be enclosed.
4.	Bus body Fabricator Experience	Bidder shall be Bus body Fabricator of Minimum 100 Nos. bus bodies in last three financial years (i.e. 2021-22, 2022-23, 2023-24) for any STU or Government Department / PSU or Chassis Manufacturer/ any Private Fleet Owner who has attached buses to Govt./STU's with proof of copies of work orders and satisfactory work completion certificate from concerned.	Attach Necessary Copies of work orders and satisfactory work completion certificate from concerned
5.	Tax Registration	The Bidder should have registration number of: (i) GST (ii) Income Tax PAN	Copies of: GST Registration Certificate & PAN
6.	Black listing & Litigation	Bidder should not have been blacklisted/debarred by any State / Central Government Office/ Department / PSU / STU/ Agencies or any Autonomous bodies during last three financial years i.e. 2021-22, 2022-23, 2023-24 and current financial year	An undertaking in this regard has to be submitted as per Annexure- B
7.	Tools and plants	<ol style="list-style-type: none">i. Shower testing of complete vehicle :ii. Battery chargers of suitable capacity.iii. Air compressor of high capacity along with tyre inflating arrangementsiv. Panel stretching machine.v. Press brake machine of capacity min 120 MT (assorted).vi. Shearing machine of	Regarding these tool & plants availability self declaration certificate has to be given by bidder.



Sr. No.	Basic Requirement	Specific Requirements	Documents Required
		capacity 6 mm thick vii. MIG welding equipments viii. DG set min 200 KVA (assorted) ix. Suitable painting booth and spray painting arrangement x. Suitable fixture for bending of roof sticks, pillars etc. xi. Pneumatic riveting machine xii. Portable drill machine, grinders and other hand tools required for fabrication work. xiii. Roof panel rolling machine. xiv. Dry film thickness measuring equipments, gloss measuring equipment and additional testing facilities xv. Hardness testing machine, Paint thickness , Micrometer ,Vernier Calipers Any required & necessary tools for body building.	
8.	Minimum bus body building capacity for RSRTC (Minimum number of chassis that may be given to bus body fabricator for bus body fabrication per Month)	150 NOs., 3X2 SUPER EXPRESS BLUELINE in a month for RSRTC	Undertaking

EVALUATION CRITERIA

The item wise lowest price quoted for the supply location i.e. Jaipur, Rajasthan in the BOQ (bill of quantity), shall be the criteria for evaluation, however the quantity may be divided among more than one Bidders at the price and conditions of the lowest evaluated Bid as below-

1. In case of TWO bidders the quantity may be divided by 70(L1):30(L2)
2. In case of THREE bidders the quantity may be divided by 50(L1):30(L2):20(L3).
3. In case of MORE THAN THREE bidders the quantity will be decided by procurement entity i.e. RSRTC.



SECTION VII :- BIDDING PROCESS

1. This Bid is invited in Open Competitive bid system i.e. Technical Bid and Financial Bid. Both the Bids (Technical and Financial) have to be prepared and submitted online by the Bidders through e-procurement portal (<https://eproc.rajasthan.gov.in>) only.
2. **All the technical bid documents along-with copy of all fees (bid documents fee, bid processing fee & bid security) shall be uploaded only in e-procurement portal. No hard copy of technical bid documents will be accepted except fees documents.**
3. Sealed envelope consisting of Fee Documents should be submitted in physical form before opening of Technical Bid. On the top of the sealed envelope, the following should be mentioned:
 - (i) Tender ID
 - (ii) Name of Tendered Item
 - (iii) Bidder Name
 - (iv) Last date of Bid Submission
4. The Bid will be opened on the date, specified in the Bid Document unless otherwise extended. The following procedure will be adopted for opening the Bid submitted by the Bidders:
 - (i) Technical Bid submitted by the Bidder will be opened online and the evaluation committee will evaluate documents submitted by the respective Bidders based on the qualification criteria. If a Bidder fails to furnish any of the required documents for fulfilling technical qualification then evaluation committee by its discretion if found suitable, may request to submit the shortfall documents (if any), and same has to be uploaded by the bidder on portal within specified time limit. If Bidder fails to submit the required shortfall documents, then Technical Bid of those bidders will be rejected and their financial bid will not be opened . The decision of the Evaluation Committee will be final and binding in this regard.
 - (ii) The Bidders who meets qualification criteria prescribed in this Bid Document and whose Technical Bids are found to be responsive Financial Bids of only those bidders will be opened online.
5. The Evaluation/ Procurement Committee shall evaluate the Financial Bid and on the basis of evaluation criteria as specified in this Bid Document will declare the Successful Bidder and the successful bidder has to enter into a contract with RSRTC specifying the terms and conditions of fabrication of buses as per bid specifications to RSRTC.



FEE DOCUMENTS

Part I - The Fee Cover shall comprise the following:

Sr. No	Particulars
1.	Bid Document Fee Rs 50000/- plus 18% GST extra i.e. 59000/- in the form of Demand draft (DD) in favour of Financial Advisor, RSRTC, Jaipur.
2.	Bid Processing Fee Rs 2500/- in the form of Demand draft (DD) in favour of Managing Director, RISL, Jaipur.
3.	Bid Security Rs 69,12,000/- (Sixty Nine Lacs Twelve Thousand only) in the shape of demand draft/Bank Guarantee payable to Financial Advisor RSRTC , Jaipur (In case of BG it should be issued from branch of Scheduled bank).(Annexure “D”)

DOCUMENTS TO BE SUBMITTED FOR TECHNICAL BID

Part II - The Technical Bid shall comprise the following:

1.	Each page of the Bid documents duly filled & signed with stamp of concerning authority.
2.	All filled Annexures with Stamp & Signature.
3.	Type approval certificate as per AIS052 revised and amended upto date for bus body fabrication on specified chassis.
4.	Bidder shall be Bus body Fabricator of Minimum 100 Nos. bus bodies in last three financial years (i.e. 2021-22, 2022-23, 2023-24) for any STU or Government Department / PSU or Chassis Manufacturer/ any Private Fleet Owner who has attached buses to Govt./STU's with proof of copies of work orders and satisfactory work completion certificate from concerned.
5.	Certificate of Incorporation/ Registration issued by the Registrar of Companies. In case of firm is in partnership/ proprietary, certified copy of the partnership deed may also be enclosed.
6.	GST registration certificate and PAN card.
7.	Insurance copy and any other required documents as mention in this bid.
8.	Proof of having type approval certificate from any one of the recognized testing agency as mentioned in rule 126 of CMVR 1989 to comply with provisions of Code of Practice for bus body design as per AIS-052 . i) Bus Body Type Approval Certificate Number Date issued by the approved Testing Agency for Wheel base 5100-5500 mm (Chassis ARAI Type Approval Certificate No. Dated). ii) Bus Body Builder Accreditation Certificate No..... dated..... valid upto..... (attach photocopies)



DOCUMENTS TO BE SUBMITTED FOR FINANCIAL BID

Part III- The Financial Bid shall comprise the following:

Sr. No	Particulars
a.	Bill of Quantity as per format in Financial Cover.

1. The Bidder shall specify the unconditional fixed basic price, discount (if applicable) and GST as per norms in the Financial Bid as per BOQ format. The Financial Bid received without specifying the breakup of fixed basic price and applicable taxes may be rejected.
2. In the BOQ the GST & discount must be quoted in percentage % only and rate should be quoted in rupees only for the supply location which is Jaipur, Rajasthan.
3. Any conditional (quantity /volume /cash) discount will not be considered except unconditional discount quoted in BOQ. So please submit the best prices in BOQ only.
4. The Period of contract shall be applicable till warranty period, however the time period for repetitive work order (Fabrication of bus bodies) shall be six months from the date of opening of technical bid.
5. No escalation of quoted basic price by the Bidder will be permitted during the contractual period with RSRTC.
6. The increase / decrease in applicable taxes/ any statutory government levies may be accepted subject to submission of documentary evidence in relation to the same to the Bidder.
7. The Financial Bid shall not contain any strike outs, over-writing, erasures or other modifications and shall be free from any clerical or computational error.



SECTION :VIII Bid Specifications

BROAD SPECIFICATIONS OF FABRICATION OF 3x2 BLUELINE PASSENGER BUS BODIES

1. GENERAL DESIGN

Stream-lined and balanced bus body with single entrance cum – exit door within the wheel base of the chassis with facing forward in 3x2 seating layout as per latest applicable bus body code AIS 052 & Latest CMVR.

2. REGULATION:

The structure of the bus body, general appearance and seat layout etc. shall be as per latest bus body code AIS052 & latest CMVR.

3. CHASSIS SELECTION:

Bus body shall be fabricated on 3X2 BLUE LINE (Wheel Base 5100 mm to 5500 mm) PASSENGER BUSES.

4. BROAD SPECIFICATIONS FOR FABRICATION OF 3X2 LAYOUT BLUE LINE BUSES WITH PASSANGER BUS SEATS (ALL DIMENSIONS IN MM)

	Parameters	Dimensions	
1.	Design of the 3X2 BLUE LINE	As per bus body code AIS 052& CMVR latest amendments.	
2.	Type of chassis on which bus to be fabricated	Chassis of wheel base 5100-5500 mm	
3	Height from window rail to cant rail	965	
4	Pillar bay size	1100	
5	Clear width of driver door & Emergency door in Structure	740	
6	clear width of passenger /saloon door in structure	740	
7	Back to back seat distance and leg space	As per Bus body Code AIS 052 & latest CMVR latest amendments	
8	Over all height ,width & length of bus	Conforming to As per Bus body Code AIS 052 or latest	
		Over all width	2560 mm+/-05mm
		Over all length	9500-10800 mm +/-25mm
		Saloon height (Cross bearer to roof stick)	1930 mm Minimum +/- 05mm



DETAILS OF STRUCTURAL MEMBERS		(ALL DIMENSIONS IN MM)	
S.No	Parameters	Material	Dimensions
1	Cross bearer	MS channel section	50x100x50x6
2	Cab under floor	MS Channel & Angle	40x75x40x6 50x50x6 , 40x40x3
3	i) Roof stick	GI pipe	40x40x2
	ii) Roof Longitude (min. 4 Nos.)	GP section	1.6mm thickness
4	Pillars , Cant rail ,Window rail ,Waist rail,	GI pipe	60x40x2
5	Diagonal bracing	GI pipe	40x40x2
6	Seat rail	MS Angle	40x40x5
7	Skirt rail	MS Angle	40x40x3
8	Floor longitude/ floor cross joint support	HRCA MS Channel	30x75x30x3
9	Rear mud guard support	MS angle	65x65x6
10	Gussets	CRCA MS sheet GP sheet	2 mm thick 1.6 mm thick
11	Gussets FES Jhula	MS sheet	170x170x6
12	Cross bearer to chassis joint (U BOLT)		
A	U BOLT	White draw bar hightensile Gr.8.8	Rod dia 16 mm AS:166:Mar,98 or latest
B	PLATE	MS PLATE	180x150x8
C	Balata packing	Balata packing	8mm thick IS:1370 or latest
D	Aluminum spacer	Aluminum spacer	110RX140X30
E	Pipe with angle with MS Plate as per drawing		
13	Pillar joint fixture (welded to cross bearer & pillar on either side)	MS plate	180x60x6
14	Front & Rear wheel Arc frame	Wheel arc of GI Pipe	40x20x2
		The Front dome of GP sheet.	1.6 mm thick
	Rear Dome	Aluminium chequered sheet	Rear mud domes shall be fabricated with and pressed out of single sheet aluminium chequered plate IS :737:1966 or latest IS/AIS/BIS



15	Front show structure and front pillar support frame with chassis –	MS angle MS channel MS plate (gussets)	50x50x6 40x75x40x6 170x170x6
16	Step well	MS angle Al chequered sheet	40x40x3 , 30x30x3 3mm thick

DETAILS OF OTHER IMPORTANT BUS BODY COMPONENTS (ALL DIMENSIONS IN MM)

S.No	Parameters	Materials and Process / Components detail
1	Flooring	<ul style="list-style-type: none"> • 3.15 mm thick anti skid aluminum chequered sheet as per Latest IS/AS. • Tar felt minimum 2 mm thickness shall be used between cross bearer and aluminum chequered sheet. • Pitch of the bolting will be 125mm. • In the gangway aluminum extruded wearing strips section 30x4mm shall be provided in 4 rows from driver cab partition to rear 6 seater. • 3 Nos. floor longitudes of MS 30x75x30x3mm U channel shall be provided.
2	Dickey/Luggage Boxes	Side dickets shall be provided having adequate space as per bus body code. The boxes shall be made dust and leak proof by using PU sealant and pitch (roffing compound) be applied at joints .
3	<p>GLASS</p> <p>i. ➤ Front</p> <p>ii. ➤ Top fixed strip for main window ➤ Top fixed strip for door window and main</p>	<p>i. "AA" laminated curved glass having thickness 6.3 +/- 0.4 mm & with PVB FILM (Poly Venyle Butyral film) thickness 0.7mm minimum. (48X48) Two piece AS:296:69:July,05 and IS:2835:1987 & IS:2553:1992 or latest IS/AS/BIS ➤ A handle / pipe shall be provided between front glasses to hold .</p> <p>ii. "A" toughened 4.8 mm thick flat glasses. Window and partition glasses shall be clear</p>



	door bay window ➤ Shutter glass for main window ➤ Shutter glasses for main door bay window ➤ Quarter window	transparent										
4	Rear wind screen glasses	Rear wind screen glasses in one piece toughened of size 2190x2130x610 of 5.5 mm thickness fitted with EPDM Rubber										
5	Main window	Al. section BW 3653 HINDALCO										
		Tie bar section SP.4257										
		Joint Plate-Al.										
		Al.415 section (F-section)										
		Al. angle										
		Al. section 1752 INDAL										
		Shutter catchers (press metal)										
		Terrene felt										
		EPDM Sweep rubber 40mm										
	Window locks to keep the windows sliders in closed position shall be of heavy duty self locking type and should be powder coated/ anodized. In between the windows sliders, EPDM sweep rubber beading shall be provided on both sliders to make complete window rattle proof and water proof. Window section shall be in F & H section as above mention or equivalent as per AIS 068.											
6	Paneling	<table border="1"> <tr> <td>A</td> <td> <ul style="list-style-type: none"> Roof Outer Aluminium 1.2 mm thick. Roof inner side, Inner panell from cant rail to seat rail shall be Aluminium (AL) 1.1 mm thick with PVC. Inner paneling from seat rail to floor level shall be in GP 1.2 mm thik with proper welding. </td> </tr> <tr> <td>B</td> <td>Sides of GP stretch panel of 0.9 mm thick</td> </tr> <tr> <td>C</td> <td>lower side panel of 1.6 mm Aluminium sheet .</td> </tr> <tr> <td>D</td> <td>Rear side paneling Aluminium 1.6 mm sheet</td> </tr> <tr> <td>E</td> <td>The complete front show shall be made of 1.2 mm GP sheet.</td> </tr> </table>	A	<ul style="list-style-type: none"> Roof Outer Aluminium 1.2 mm thick. Roof inner side, Inner panell from cant rail to seat rail shall be Aluminium (AL) 1.1 mm thick with PVC. Inner paneling from seat rail to floor level shall be in GP 1.2 mm thik with proper welding. 	B	Sides of GP stretch panel of 0.9 mm thick	C	lower side panel of 1.6 mm Aluminium sheet .	D	Rear side paneling Aluminium 1.6 mm sheet	E	The complete front show shall be made of 1.2 mm GP sheet.
A	<ul style="list-style-type: none"> Roof Outer Aluminium 1.2 mm thick. Roof inner side, Inner panell from cant rail to seat rail shall be Aluminium (AL) 1.1 mm thick with PVC. Inner paneling from seat rail to floor level shall be in GP 1.2 mm thik with proper welding. 											
B	Sides of GP stretch panel of 0.9 mm thick											
C	lower side panel of 1.6 mm Aluminium sheet .											
D	Rear side paneling Aluminium 1.6 mm sheet											
E	The complete front show shall be made of 1.2 mm GP sheet.											
7	Wiper machine	Wiper motors shall be fitted with arm and blades separately for driver and conductor side. Wiper arms and blades shall be heavy duty type.wiper motor shall be provided by chassis manufacture/supplier.										
8	Head light	4 Nos original fitted with chassis. If 2 head lights supplied with chassis then 2 extra lights of OEM make shall be fitted which will be finalized by RSRTC.										
9	Lighting arrangement	4 nos. LED lights to be provided of OEM make for proper light inside passenger saloon. Minimum 2 nos. coloured night lamps of OEM make also be provided in the passenger saloon. Rest light arrangements as per provisions of bus body code.										
10	Front grill	As per bus body code for sufficient and adequate air intake.										
11	Driver cabin partition	Separate full driver cabin partition as per bus body code AIS 052 & Latest CMVR and latest RSRTC fleet.										
12	Parcel rack	19mm ODx1.6 ERW Pipes with MS Brackets										
13	Front quarter window	As per drawing										



14	Passenger door	As per bus body code
	J&K door	GI pipe 30x30x2 or suitable size GI Pipe
	J&K door GP sheet finishers	GP sheet
	Heavy duty tower bolt	MS 10mm dia x200mm
	Heavy duty railway lock	MS plate30x6
In the Upper half of the saloon door, fixed glasses of size as per drawing shall be fitted with EPDM 30 mm rubber and aluminum sheet cut out. A good quality grab handles 250x8 mm be provided on the saloon door for opening and closing. The handles shall be through bolted for better strength.		
<ul style="list-style-type: none">• Manual J&K door as per AIS – 052• For Door design also refer our latest same model of RSRTC fleet.		
Paneling of the saloon door shall be of 1.2mm aluminum sheet on both sides duly riveted and canopy is also to be provided above the saloon entrance		
15	Driver door	As per bus body code Section for rubber beading shall be provided, heavy duty lock shall be provided.
16	Emergency door (AIS – 052 or prevailing bus body code at the time of fabrication)	As per AIS 052
17	Protector cum saloon grab pipe	ERW pipe 25/38x2.
		PVC sleeve 2mm thick
		T- & Cup Brackets Drop forged chrome plated
18	Front & Rear bumper	MS sheet 2mm thick
19	Diesel tank neck cover	MS sheet 2mm thick
20	Rub rail with rubber buffer	EPDM & Al. section
21	Battery box	1.6mm thickness stainless steel (Acid proof) & CRCA with FRP lining.
22	First aid & complaint box	GP sheet 1mm thick
23	Tool box (in driver cabin)	MS sheet, With Frame of angle bottom and top & cross support with cushion & rexine
24	LED Destination board of OEM Make behind left wind screen and at rear glass in middle position As per AIS-052	Front :900x200 mm minimum
		Rear :900x200 mm minimum
25	General structure details for reference	
a.	Side elevation	As per drawing
b.	Front structure	As per drawing
c.	Rear end structure	As per drawing
26	Insulation	Complete bus body shall be provided with high density thermocole insulation for maintaining proper temperature in saloon as per bus body



		code
27	COLOUR SCHEME AND GRAPHICS	PU paint of OEM make shall be used, Colour scheme shall be as similar to the existing colour scheme of RSRTC for 3x2 layout Blueline. Colour scheme will be finalized by RSRTC.
	<p>The Polyurethane (PU) paint conforming to BIS : 13213-1991 or latest IS/AS/BIS shall be used for exteriors and interiors of bus, where ever required .</p> <p>Details of paints used, surface treatment & preparation, corrosion prevention treatment, base primer coating, number of paint coats to be applied etc shall be provided by the contractor.</p> <p>All exterior surfaces shall be smooth & free of wrinkles & dent. Exterior surface to be painted shall be prepared as required by the Paint system supplier, prior to application of paint to assure a proper bond between the basic surface and succession coat of original paint for the service life of the bus. Paint shall be applied smoothly and even with the finish surface free of dirt and the other imperfections.</p>	
i.	CONVENTIONAL (P.U.2K) SYSTEM FOR PAINTING PROCESS OF BUS BODY	
	<p>STEP 1. SURFACE PREPARATION Clean the surface thoroughly to insure removal of oil , grease , dirt and dust by using degreasing Chemical and grinder (buffing) .</p> <p>STEP 2. PRIMER COAT (2K SUPER EPOXY ZINC PH . PRIMER GREY) FOR GLAVANISED & ALUMINIUM SURFACE - Apply one coat of zinc etch primer yellow DFT 5-15 microns , FOR ANY OTHER SURFACES- Apply one coat of 2k super Epoxy zinc ph . Primer grey diluting with Epoxy Thinner 40-50 % by volume . And let a dry for 4 hours . Sand it with 320 Emery paper . DFT - 30-40 microns .</p> <p>STEP 3. APPLICATION OF PUTTY Apply coat p.u. putty off white (body filler) properly to fill the minor dent to make the surface smooth And dry for 2 hours . Sand with 320 Emery paper . DFT - Not more than 1 mm .</p> <p>STEP 4. 2K PU PRIMER SURFACER Apply second coat of 2k P.U.H.B.P.S Grey diluting with Thinner up to 30-40 % . And Dry For 2-3 Hours . Sand it with 400 Emery Paper . DFT - 30-40 microns .</p> <p>STEP 5. APPLICATION OF 2-3 COATS OF PU - 2K SHADES :-Apply 2-3 coat of P.U. Paint wet to wet , Diluting With PU Thinner Up to 30-40 % and dry for 4-6 Hours Total DFT - 100 + microns .</p> <p>STEP 6. APPLICATION OF UNDER BODY SURFACE _; Apply 1-2 coats of chassis mat black and dry for 4-6 Hours . Total DFT 40 -50 microns.</p>	
ii.	Skirt rail to top of both bumpers (Appx. 12" height) covering both the bumpers (on all the 4 sides.)	Tata blue
iii.	A Band of 55mm width on 3 sides i.e. on both sides panels and rear panel.	Yellow fluorescent reflective tape 55mm width running across the length of the body above the rub rail. On rear panel Red fluorescent tape be used.
iv.	Above S.No.1, upto Rub-rail – size Appx. 9" height (on all the 3 sides) i.e. on both the side panels and rear panel.	Soft gray
v.	40 mm below rub rail	Tata blue strip
vi.	Above rub rail to roof top	Marble White
vii.	A strip of 3" width has to be provided 3" above the water cutter on both side top curves. It will include both the indicator lights fitted on each side top.	Tata Blue



viii	Front End Show (FES) as per existing. The inside colour graphics, writing work, and writing work on FES & RES be as per RSRTC. All the interior surfaces of saloon and driver cab except PVC laminated ash gray colour shall be enamel paint coated matching with the colour of PVC laminated sheet.	
28	PASSENGER SEATS: As per AIS 023 or OEM Make or Railways make	
i.	Type of Seats	<p>a) 2 seater and 3 seater - ERW frame having common bottom seat cushion and back rest for individual passengers without arm rest, suitable for fixing in Super Express – Blue line buses in 3x2 layout</p> <p>b) Back rest should be curved high back with fixed head rest.</p>
ii	Seat Material/ Size	<p>a). 3 seater – 1220x406x90x65 +/-10mm – No negative tolerance on thickness</p> <p>b). 2 seater - 812x406x90x65 +/- 10mm – No negative tolerance on thickness</p> <p>c). Seat upholstery – expanded vinyl coated fabric (foam leather conforming to Gr.I Type –A "DARK BLUE" (RADO shade) as per AS RDSO CG-07: Feb.,06 or latest.</p>
iii.	Seat belts to be provided as per CMVR / AIS 052 / AIS 005/AIS 015	
29	Lights & Wirings as per bus body code	
A	Head light	As per bus body code & CMVR with latest amendments
B	Night lamp	
C	Front indicator	
D	Rear tail light	
E	Conductor bell (Elect)	Electric buzzer 1 No. 24V as per bus body code .
F	Public announcement system	As per AIS-052 or prevailing bus body code & CMVR with latest amendments
G	MAIN SUPPLY SWITCH BOARD: PVC insulated LT wire conforming to IS:694 or latest AS/IS/BIS as per bus body code and CMVR	
H	SALOON WIRING: PVC insulated LT wire conforming to IS:694 or latest AS/IS/BIS as per bus body code and CMVR	
30	During fabrication work , followings are taken care of	
	<ul style="list-style-type: none"> ➤ All the structural members and other body components should be Epoxy Zinc phosphate coated. Epoxy primer is to be provided on the inner side of the entire panel sheet. ➤ The reinforcement should be provided for the full developed length of roof stick in single piece 40X40X2 mm. ➤ Before roof exterior paneling specified tar-felt covering 2mm thick on full length and full width of roof sticks and roof longitudes, protruding 2mm outside the width of roof sticks and roof longitudes shall be provided. ➤ The side structure shall be receded back by rear wheel to back quarter approximately size shall be 700mmDX600mmH & 2bay of 2300mm. ➤ Before fixing interior roof paneling 40mm thermocole packing should be fixed throughout the length between roof longitudes. Thermocole sheet of 20mm thickness in 2 layers should be fixed on the roof corners throughout the length. ➤ Cab floor frame structure shall be fabricated. 	



- Front grill be provided in bolts.
- PVC laminated aluminium sheet of 1.1 mm thickness grey shade colour of existing rsrtc buses for Interior roof paneling ,Window finishers, casing and inside pillar covers from window rail to cant rail .
- The exterior panel roof joints shall be longitudinal and shall be inter locked by joggle joint and shall be solid riveted with Aluminium NR-5, 5mm dia rivets with roof sticks and roof longitudes. At cant rail level a continuous water channel shall be provided on longitudinal sides of roof for drainage of water and to prevent water to fall on the windows and driver door and to ensure water proofing. The water channel should also be provided above the rear wind shield glasses to avoid water leakage through emergency door.
- During fitment U bolt nylock nuts should be tightened properly with torque wrench at the specified torque of 12 to 14 m-kg.
- **PARCEL RACKS:**
Parcel rack brackets shall be made of 2mm thick MS rectangular pipe. The brackets shall be bolted with pillars and roof longitudes with MS high tensile bolt 5/16" size with spring washer and anabond locking compound (with 2 bolts on pillars and 2 bolts on roof longitudes on each bracket). ERW pipe 19mm ODx1.6mm thick passing through the holes of the brackets should be fitted and MIG welded with the bracket. The complete parcel rack should be epoxy zinc phosphate coating and black painted. Minimum 9" clear gap should be maintained between the roof and parcel rack.
- **HORIZONTAL STANDEE BAR:**There shall be one horizontal bar of MS ERW pipe 25mm ODx2mm thick duly black PVC sleeved 2 mm thick. It shall be provided in full length of saloon
- **PROTECTOR CUM SALOON DOOR GRAB PIPE:** At passenger door in front of 2 seater, protector cum grab pipe with roof support pillar shall be provided as per drawing. This will be bolted with roof top as well as floor by means of MS drop forged single piece cup brackets. A saloon grab pipe shall also be provided with MS drop forged cup brackets.
- Window locks to keep the windows sliders in closed position shall be of heavy duty self locking type and should be powder coated/ anodized. In between the windows sliders, EPDM sweep rubber beading shall be provided on both sliders to make complete window rattle proof and water proof.
- Both the quarter window glasses should be clear, transparent. Window guard rail with 20mm dia ERW pipe with PVC sleeves 1 mm thick shall be provided at 150mm above the window rail on outer side. The brackets shall be fixed directly on pillars 60x40x2 and be through bolted for better strength.
- All wires should be PVC covered.
- Original battery cable of the chassis be used in single length conforming to AS:84:61: Oct.,2000 or latest AS/IS/BIS.
- The original battery cut off switch shall be provided As per AIS 052 and CMVR.
- Positive wire shall be in red colour and negative wires in black colour. Other colours may be used for loops etc. for special identification purpose..
- The earth return system shall be used for bus body wires.
- 4 Nos. indicator lights on all the roof top corners be also provided.
- 2 Nos. indicator bulbs be provided in driver cabin for attention of driver.
- One LED roof light to be provided at top of passenger door with switch near it to facilitate conductor. A footlight at step well be provided.
- 2 Nos. rear view mirror, (One on each side) of heavy duty adjustable convex type should be provided. 01 Rear view mirror in driver cabin at rear side of front show.
- Readymade passenger bus seats As per AIS 023/ OEM/ Railways shall be fitted by the body builders as per seat lay out and maintaining equal pitch and adequate leg space. 100 to 150 mm taper be given on driver partition on lower portion to provide adequate leg space to passenger on front seats and for other seats leg space & gangway strictly



maintained as per bus body code.

- Window corner gussets in single piece of GP sheet 1.6 mm thick be provided
- Front bumper should be in 3 pieces preferably folding type.
- For permit and toll tax papers , Separate box in driver cabin be provided
- All door locks of heavy duty shall be provided.
- USB type mobile Charging facilities shall be provided at each row in passenger saloon.
- ETIM charging facility shall be provided in driver cabin at suitable place.
- Front bumper of the vehicle shall be affixed with white reflective tape 50 mm width and at the rear bumper with red reflective tape 50 mm width running across the width of the body & also 1 Meter length of red tape shall be affixed vertically on the outer boundary of the vehicle on RES and the sides of the vehicles shall be affixed with yellow reflective tape 75mm width running across the length of the body. All reflective tape shall be as per CMVR.
- 2 reflectors to be fitted on the rear end.
- Top & side markers, indicators shall be as per AIS 052.
- One step of 6"x6" size shall be provided near driver door.
- Steps shall be provided for emergency exit/door.
- One step shall be provided at front bumper for cleaning of front wind shield glass.
- Diesel tank neck cover shall be provided (flap type) with one tower bolt.
- Diesel tank Zali be provided in neck duly riveted to prevent diesel pilferage.
- Urea / Adblue tank flap opening provision shall be provided.
- Battery box shall be provided between front axle and passenger door.
- Dash board angle is to be receded back to make room for top up of water in radiator and oil in steering oil reservoir.
- Traps for gear box, gear lever in driver cab be provided as per requirement.
- To provide an "Advertisement Board" of size 1220 x 762 mm (48"x30") of GP sheet at the rear end panel of the bus body under fabrication. Finally board should be painted white.
- Water bottle holder, a pipe shall be fitted at suitable place in driver cabin.
- Adjustable sun visor at driver side shall be provided for windshield.
- Heavy duty lock also be provided in driver door.
- Mud guards/flap of good quality shall be provided.
- Railway type locks shall be provided in all luggage and battery box.
- Heavy duty ring type towing device shall be provided in the front with load transfer to bus structural members. The capacity of each towing device shall be Minimum 1.2 times the kurb weight of the bus.
- Drop forged toe hook shall be provided at rear end.
- All EPDM rubbers colour shall be black.
- First aid box with complete Medical items with valid time period, medicines, bandages shall be provided as per CMVR and AIS 052.
- Materials used in bus body fabrication shall be Fire Retardant (FR) grade as per bus body code.
- Fire extinguishers shall be provided as per Bus body code and latest CMVR amendments.
- The bus body fabrication shall be done with all applicable fire safety and exhaust emission regulations.
- The rear number plates should be fixed below window rail.
- Cross bearer shall be in box type before and after rear axle.
- Foldable window (aluminium section) in driver cabin for ECU box if required.
- Shower test shall be carried out after completion of body work for checking of any leakage of water.

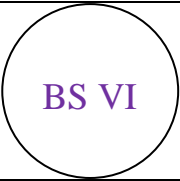

31		LETTER WRITING AND LOGO & STICKERS
i.	**राजस्थान राज्य पथ परिवहन निगम** has to be written in HINDI on both side stretch panels :- i. On conductor side, ahead of passenger door below the 2 main windows, ii. On driver side, 50mm before driver door below the 2 main windows. ‘ iii. Size of the letters shall be 150 mm height x 1620 mm span.	Tata Blue Fluorescent stickers
ii	"RSRTC" logo on both side panels, FES & RES has to be provided as per drawings & specifications.	Tata Blue Fluorescent stickers
iii	 BS VI in 8" dia circle has to be written, as case may be, on FES LH side	Dark Green Fluorescent sticker
iv	Name of the depot to be written on :- ☞ On top of front wind screen ☞ On outer top rear dome of letter size 125 mm height.	- Red Fluorescent sticker with yellow back ground putta 250 mm width. -Tata Blue Fluorescent stickers instead of Violet purple stickers.
v	"RSRTC" to be written on FES just below joint of front wind screen glasses of letter size 75 mm height	Red Fluorescent stickers
vi	"RSRTC" logo on both side panels, FES & RES has to be provided as per drawings & specifications.	Tata Blue Fluorescent stickers
vii	Slogans 1. फर्स्ट एंड बॉक्स, सुझाव पुस्तिका चालक केबिन में उपलब्ध है। -शिकायत एवं सुझाव के लिये टॉल फ्री न.18002000103 - दूरभाष नियन्त्रण कक्ष मुख्यालय, जयपुर . फोन. 9549456745 - मुख्य प्रबन्धक न. - प्रबन्धक(संचालन) न..... - प्रबन्धक(यातायात) न..... 2. धूम्रपान वर्जित है।(स्टीकर लाल रंग में) 3. संकट द्वार (लाल रंग में 40एमएम साईज) 4. "यात्री किसी अनजान व्यक्ति से कोई वस्तु न लें" 5. "यात्री कोई संदिग्ध /लावारिस वस्तु को न छुये व उसकी सूचना तुरन्त चालक अथवा परिचालक को दें" 6. ई-टिकटिंग के माध्यम से टिकट प्राप्त करने हेतु निगम की website: www.rsrtconline.rajasthan.gov.in पर लोग ऑन करें। 7. <ul style="list-style-type: none">• बिना टिकट यात्रा करना दण्डनीय अपराध है।• बिना टिकट यात्री से किराये का 10 गुना या 2000रु जो भी कम हो, जुर्माना वसूला जायेगा।• यात्री द्वारा जुर्माना राशि नहीं देने पर 1 माह की कैद या 250रु का अर्थदण्ड अथवा दोनों की सजा हो सकती है।• परिचालक से उपयुक्त टिकट लेना यात्री का कर्तव्य है।	1. टॉप RH साइड पार्टीशन पर (लाल रंग में 40एमएम साईज) - टॉप RH साइड पार्टीशन पर स्लोगन न.1 के नीचे (काले रंग में 40एमएम साईज) 2. चालक पार्टीशन पर ऊपर की तरफ मध्य में व ठीक इसके सामने पीछे डोम के मध्य में 3. संकट द्वार के गार्निश रेल के मध्य में 4. टॉप LH साइड पार्टीशन पर सैलून में (लाल रंग में 40एमएम साईज) 5. टॉप LH साइड पार्टीशन पर सैलून में (लाल रंग में 40एमएम साईज) 6. टॉप LH साइड पार्टीशन पर सैलून में (लाल रंग में 40एमएम साईज) 7. टॉप LH साइड पार्टीशन पर काले रंग में 40 एमएम साईज ।



<p>8. निगम की बसें राष्ट्रीय धरोहर हैं। इनकी सुरक्षा करना हमारा कर्तव्य है।</p> <p>9. "बस रुकने पर सावधानी से, आगे मुँह करके उतरें"।</p> <p>10. ध्यान दें:- दुर्घटना रहित बस संचालन एवं डीजल बचत पर</p> <p>11. Name of the depot to be written on :- ☞ On top of front wind screen both the glasses of letter size 140 mm height ☞ On outer top rear dome of letter size 125 mm height^०</p> <p>डिपो का नाम (उदाहरण के लिये - "जयपुर डिपो")</p> <p>12. "आपकी यात्रा मंगलमय हो"</p> <p>13. विधायक सीट</p> <p>14. महिला सीट</p> <p>15. दिव्यांग सीट</p>	<p>8. अन्दर यात्री फाटक के ऊपर लिखें (काले रंग में 40 एमएम साईज)</p> <p>9. अन्दर यात्री फाटक के ऊपर के नीचे लाल रंग में 40एमएम साईज में लिखें।</p> <p>10. ड्राइवर सीट के सामने टॉप डोम मध्य में अंकित करें। (लाल रंग में 40एमएम साईज)</p> <p>11. Red Fluorescent sticker with yellow back ground putta 250 mm width. -Tata Blue Fluorescent stickers</p> <p>12. बाहर यात्री फाटक के ऊपर बोर्ड पर लाल रंग में 75एमएम साईज में लिखें।</p> <p>13,14 व 15 यथा स्थान पर लाल रंग में लिखें।</p>
--	--

Note-

1. RSRTC has given bus body drawing along with this document only for references however the Bus body fabrication must be as per latest / prevailing bus body code and CMVR. If there is any discrepancy between the specifications given and bus body code, the bus body code shall prevail.
2. Bus body fabrication must be comply with latest bus body code and CMVR however specification is submitted for the purpose of reference for standardization and similarity of RSRTC owned buses. Bidder may inspect RSRTC old bus of same category before fabrication for standardization and similarity of RSRTC owned buses.
3. Latest or prevailing IS/ AS /BIS shall be applicable for materials of bus body fabrication as per bus body code AIS 052 and the samples material used in fabrication shall be got tested accordingly on Latest or prevailing IS/ AS /BIS from CIRT/ ARAI/ICAT /NABL accredited etc laboratory. After fabrication bus must be registered at transport department.
4. Regarding VTS & Panic button etc, provision with wiring for proper installation shall be as per AIS 140. However VTS, panic buttons with wirings shall be provided by RSRTC.
5. For the slogan/logo/sticker to be written inside/Outside the buses, it would be appropriate to include the points mentioned in these Documents after approval of RSRTC. Any Other logo/sticker shall be as per requirement of RSRTC
6. Seat Nos for specially abled person, Ladies seat with pink colour, MP/MLA ,Senior citizens etc shall be confirmed by RSRTC.
7. OEM means supplier to chassis manufacturer i.e. M/s Tata Motors Ltd., M/s Ashok Leyland Ltd., M/s VECV. For the proof of OEM materials bidder have to submit copy of invoices for material supplied to chassis manufacturer i.e. M/s Tata Motors Ltd., M/s Ashok Leyland Ltd., M/s Volvo Eicher Commercial Vehicle (VECV).



SECTION IX : GENERAL TERMS AND CONDITIONS OF THE CONTRACT

1. GENERAL DIRECTIONS:

- A. The body should be rattle proof, dust proof and leak proof. When the chassis remain in the custody of the body builder, they should maintain the batteries by TRICLE CHARGE free of cost. Modification to the fuel tank/ radiator neck, if any, should be carried out by the body builder as per directions without any cost.
- B. Inspection of the bus body shall be mainly in the following 2 stages. Body Builders should offer stages inspections after rectifying the defects communicated to him at the earlier stage of inspection, then only they will be allowed to go for next stage. Body Builder has to inform General Manager (Quality/Control) of RSRTC in writing for stage wise inspection with the chassis numbers as per terms of Agreement.

Ist stage	After completion structure and stretch panel.
2 nd & Final stage	Complete finished bus body including shower test before despatch of completed bus with movement order from Inspecting Authority.

- C. The vehicle shall be road tested before final inspection for the following possible defects:-

I	Dust proofness
II	Rattle proofness of windows,locks, body panels, parcel racks, doors, seat frames, driver partition, dash board etc

- D. Following workmanship must be carefully followed.

I	All castings must be truly formed and free from visible blow holes.
II	All the bolts and rivets should be well fastened.
III	All welded joints must be chipped and well ground to get smooth surface.
IV	Sharp corner should be ground and made smooth.
V	Wherever pitch between rivets/ bolts are not/ specified , it shall be 100 mm.
VI	Bolts ends should protrude 2 to 3 threads length above the nuts.
VII	Before commencement of the bus body fabrication all the important units of chassis i.e. alternator, self starter, radiator, tyres, batteries, plastic air pipes, silencer , urea / Adblue tank etc. to be protected to prevent from damages due to welding, drilling, cutting, hammering, riveting, falling of metal scrap or dust particles etc.
VIII	Cleats shall be degreased by duly immersing in soda/ detergent water after punching without fail.
IX	Power steering pipes etc. to be clamped properly without any sag.
X	Any other work i.e related to workman ship.



E. WARRANTEY :

I	In general condition, warrantey for the bus body and other materials shall be for a period of two year from the date of Registration of the bus or till the vehicle has covered 3 lacs Kms whichever is later.
II	During the warranty period, if any defect is observed on account of poor workmanship as well as material, such defects shall be attended by the body builder, failing which if repair of such vehicle is done by the RSRTC then actual expenditure incurred for repair of such vehicles shall be recovered from the bus body fabricator /contractor.
III	The contractor would be obliged to attend the defects of the bus bodies developed during the warranty period at the place of the Corporation of the said vehicles. Thereafter the contractor shall also obtain a Certificate from the Manager (Operation) concerned and submit the same to the General Manager (Q/C) in support of having attended the work/ defects.

- F. In case of any doubt in specifications and drawings, same may be got clarified from the General Manager (B/B) immediately after receipt of work order and before receiving of chassis.
- G. Body builder should fix their firms' plate / monogram with address & valid Contact Number and all details at the rear exterior end of the vehicle.
- H. Attention of the body builders is called for considering the following points during fabrication of the bus bodies:-
- i. Air cleaner assembly on LH side on bracket to be receded back by 2 bolt holes and secured firmally.
 - ii. Cab floor channel 40x75x40x6 on LH side be fixed directly on two chassis brackets without cleats to accommodate air cleaner intake pipe.
 - iii. Dash board angle is to be receded back by 50 mm to make room for top up of water in radiator and oil in steering oil reservoir .
 - iv. Hand brake flick valve be mounted offset from the driver door, if need be.
 - v. Passenger door grab handle and driver door grab handle be placed directly on the GI pipe and through bolted.
 - vi. Steering support plate be reinforced with structure to avoid rattling.
 - vii. 4-core wiring with socket and switch for LED display board should be provided in driver cabin above LH quarter window duly flushed inside the inner paneling and at rear on the LH in the same manner.
 - viii. All material used in fabrication of bus bodies shall be as per prevailing IS / AS or BIS
 - ix. OEM means supplier to chassis manufacturer i.e. M/s Tata Motors Ltd., M/s Ashok Leyland Ltd., M/s VECV.



2. PERIOD OF CONTRACT:

The Period of contract shall be applicable till warranty period, however the time period for repetitive work order (Fabrication of bus bodies) shall be Six months from the date of opening of technical bid.

3. PERFORMANCE SECURITY:

- a. The Bus body fabricator at the time of signing the agreement shall provide a Performance Security @ 10% of the order value and shall be valid beyond 6 months from the completion of warranty period of last supplied bus in the form of Bank Draft or Banker Cheque or bank guarantee [to be confirmed by bank], in specified format, of any Scheduled bank (**Annexure “G”**) except the departments of the state Government and undertaking, corporation, autonomous bodies, registered societies, co-operative societies which are owned or controlled or managed by the state Government and undertaking of the Central Government. However, security declaration shall be submitted by them.
- b. The Performance Security shall be forfeited and shall be payable as compensation to the Procuring Entity for any of the events mentioned below:
 - (a) when the Supplier/ bus body fabricator fails to commence the supply of the Goods or Related Services as per supply order within the time specified; or
 - (b) when Supplier / bus body fabricator fails to make complete supply of the Goods or Related Services satisfactorily within the time specified; or
 - (c) when any terms and conditions of the contract is breached; or
 - (d) to adjust any accepted dues against the Supplier/ bus body fabricator from any other contract with the Procuring Entity; or
 - (e) failure by the Bidder to pay the Procuring Entity any established dues under any other contract; or
 - (f) if the Supplier/ bus body fabricator breaches any provision of the Code of Integrity prescribed for Bidders specified in the Act and Chapter VI of the Rules.
- c. Notice of 15 days' time will be given in case of forfeiture of Performance Security.
- d. The decision of the Procuring Entity in this regard shall be final.
- e. The performance security does not carry any interest.
- f. Performance security deposited (PSD) by the successful bidder shall be valid beyond 6 months from the completion of warranty period of any bus fabricated by bidder. In case where 2 year has been completed but 3 lacs kilometer is not completed of the any chassis then in such a case, successful bidder is required to extend performance security for beyond six months of the remaining period of warranty within a period of 30 Days before expiry of PSD, Otherwise before 15 days of expiry, the PSD will be revoked.
- g. In case of force majeure if warranty/contract period is extended than performance security will also be extended for the above period.

4. Contract /work order Price

- i. The price quoted in the commercial bid i.e. BOQ submitted or finalized price thereafter through e-portal mode will be considered for agreement / work order.
- ii. The bidder shall submit the financial bid electronically through e-procurement portal only. No hard copy of financial bid will be accepted.
- iii. The documents uploaded in the e-procurement portal will only be considered.



5. Terms of Payment

- (a) Payments shall be made after delivery of the buses (complete in all respect) to RSRTC as below –
Payment will be made within 30 working days of RSRTC.
However, if the Contractor does not submit the necessary documents related to above payments within prescribed time as required, the responsibility for the same shall devolve on the Contractor.
- (b) A certificate from the Authorized Representative shall in no way rander free or relieve the contract for any loss, injury or damage, which may result from the use of improper material or wormanship or omission in the workmanship which might have escaped the attention of the Authorized Representative of the Corporation.

6. Taxes and Duties

For fabrication of bus, the fabricator shall be entirely responsible for all taxes, duties, license fees, etc., incurred until delivery of the contracted Bus at site to the Procuring Entity. However GST will be quoted in BOQ. The rates should be quoted for the supply location i.e. Jaipur, Rajasthan.

7. DELIVERY/ SUPPLY SCHEDULE:

- i. The contractor shall fabricate the specified bus bodies as per specifications & bus body code within a period of 40 days time to the Corporation after release order. The delivery period shall be counted from the date of issue of release order in connection with the allotment of chassis to the Contractor. **The save days on any chassis due to early delivery of bus bodies can be adjusted to a maximum of 10 days. As regards save days on any chassis due to early delivery of bus bodies earned later on will not be adjusted against the early with held amount against the later delivery of buses.**
- ii. The fabrication period shall be counted up to the 2nd and final stage inspection approval at site.
- iii. The contractor shall be allowed a reasonable transportation time for transporting the chassis / bus body from & to his factory site from JAIPUR on the following basis:

0 to 50 Kms	- Nil
51 to 300 Kms	- One day
For every additional 300 Kms.	- One day
- iv. Extra time taken for transportation of bus bodies shall be subject to penalty clause.
- v. The contractor on completion and approval of the bus body shall be obliged to transport the vehicle/s to the Head Office, RSRTC, Jaipur with his driver. The contractor shall also arrange for the temporary registration certificate for the vehicles during the transportation from the contractor's place to the intimated destination/ depot of RSRTC before dispatch of the vehicles. The contractor shall get the TRCs renewed from time to time at his own cost as may be required.
- vi. If the contractor's driver is found carrying the passengers in the bus in transit to the destination / depot, a penalty equivalent to the full capacity of fare of the bus from the factory of the Contractor to the destination depot shall be charged. In case of an accident, the Contractor shall be fully liable for the payment of all type of compensation / damages penalties/ payment as the case may be as per orders of the court or as per out of Court settlement which may include passengers claims or claim of the legal heirs.
- vii. Chassis shall be delivered by the corporation to the contractor at JAIPUR for bus body fabrication.



8. SAMPLES, INSPECTIONS AND TESTS: The following is relevant in terms of inspections and tests to be carried out by RSRTC:

- (A) The Authorized Representative of the Corporation shall inspect the bus bodies under fabrication as per schedule stipulated. The Inspecting Authority shall have right to suggest the modification in fabrication work while pointing out the defects in the workmanship. Further, if Inspector notices the material other than what has been specified is used then the same shall be replaced by the Contractor on the insistence of the organization's representative, at the contractor's cost.

The 1st stage inspection shall be after the completion of the frame work i.e. complete structure with stretch panel which includes verification of broad structural dimensions as per specifications and quality of workmanship, mainly welding and alignment of the structure.

The 2nd and Final stage inspection shall be final inspection of finished bus painting, interior decoration, seat fixing, shutter, water leakage test etc. The Inspecting Authority will give the necessary movement orders (Gate pass) for the bus to the Head-Office, RSRTC, Jaipur.

Surprise Inspection will be made at any stage or any time during bus body fabrication. Samples may be taken of any material during such type of inspections.

Contractor shall make a written request to the Authorized Representative of RSRTC, Jaipur for the inspection of aforesaid stages as per schedule meant.

- i. The local and outside Contractors located within 350 Kms. of JAIPUR shall intimate by at least 3 working days in advance before the proposed inspection date.
- ii. The contractor located at a distance of more than 350 Kms. from Jaipur shall intimate tentatively at least by 10 working days in advance before the proposed inspection date, subject to the confirmation of the same by the Contractor with a margin of at least 3 working days. If the contractor fails to respond to the tentative inspection call given by him and does not offer the vehicle for inspection as per program such an act of omission shall be viewed against him.
- iii. After the approval of Ist stage inspection, the Contractor will proceed further for the next stage working. The Corporation reserves the right to point out any defect in the material used, workmanship, quality of stores used etc. at any stage and the Contractor shall abide by the advice of the Inspecting Authority which will not be challengeable on the grounds that the said defects were not pointed during the earlier inspections.

- (B) The following inspection schedule is indicated for the guidance of the Contractor:

Ist stage Within 20 days from the date of issue of release order of chassis.

2nd & Final stage 20 days time i.e. final finishing should be done within 40 days.

In case progress of bus body fabrication of the Contractor is found unsatisfactory and stage inspections are not expected to be completed as per stipulated time schedule given above, Corporation shall be at liberty to cancel the allotment made for which the chassis had not been lifted, if any.



- (C) Bus Body material from BIS/IS certified manufacturer, must be used during fabrication stages of bus bodies. Verification of the material used would be done on the basis of material purchase bills and relevant BIS/IS certificate of manufacturer provided by the fabricator, simultaneously by collecting the samples of material used in fabrication at different stages by the Inspectors. The samples collected shall be got tested from CIRT/ ARAI/ICAT /NABL accredited etc laboratory. In case any bus body material does not have BIS/IS standard then contractor will inform to RSRTC in advance.
- i) If any sample fails, recovery shall be made two times of the penalty calculated on pro-rata basis as per penalty clause in CIRT/ASRTU rate contract for that lot i.e. release order of buses fabricated, simultaneously testing charges and administrative charges shall also be recovered from the contractor. In any unforeseen condition the sample failure penalty calculation decision of the corporation shall be final and binding upon the contractor. The maximum penalty for sample failure will be up to 100% of that sample material cost.
 - ii) The Contractor have to provide copy of material purchase bills of collected samples to RSRTC inspector/s at the time of sample collection.
- (D) Whenever for any material BIS / IS, ASRTU or any other specifications have been prescribed in the broad specifications provided by RSRTC besides tolerance and other technical conditions, the same will be applicable for the material used for the bus body fabrication and the said material must necessarily confirm to such parameters as may be specified.
- (E) The bus bodies shall be fabricated in accordance with the broad specifications as per AIS 052 for using high quality standard material which will form a part of Agreement. The decision of the Corporation in this regard shall be final and binding upon the contractor. In case the material is not approved by the Corporation, the same shall be rejected and shall be required to be replaced by the Contractor as per directions of the Corporation. Any loss caused to the Contractor as a consequence of such rejection or replacement shall be entirely to the contractor's account and for this the Contractor shall have no right to claim or challenge the decision of the Corporation.
- (F) The authorized representative of the Corporation shall be at all reasonable times have the access to the Contractor's premises and shall have the authority to inspect and examine the material used and the workmanship of the bodies as and when required.

9. TRAINING FOR TECHNICAL STAFF:-

The bus body fabricator shall have impart training on FOC basis to RSRTC staff at RSRTC 8 Zonal head quarter Depots/ 3 Central Workshops for handling LED destination board.

10. TRANSPORTATION: The Buses shall be supplied for the supply location i.e. Jaipur, Rajasthan. All transportation charges, local taxes, etc. shall be borne by the bus body fabricator. No other charges will be paid to supply except quoted in BOQ.



11. INSURANCE:

- i. The buses shall be insured to safeguard against any transit damage/loss. In case, the bus body is not insured, the bus body fabricator will have to make good to the loss sustained by the corporation, if any.
- ii. Contractor will get the insurance cover at his own cost for entire period for which the chassis would be retained in his factory against fire, theft, flood, rebellion, riots. Accidents and undue exposure or weather or otherwise for the full cost. In case the chassis remain with the contractor at his factory after expiry of the insurance period, then the contractor will be liable to get the insurance cover obtained prior to the expiry of the said policy factory insurance shall be for full period of holding the chassis against fire and burglary i.e. till chassis are kept in factory for fabrication purpose without break in between. However, in case of default, the contractor would be fully liable for any damage to chassis/ bus body if any and at the same time, contractor would also be liable to pay Rs. 200 + GST per day per chassis to the corporation on account of such default. Contractor should have all necessary documents regarding factory licences at own cost.

12. RISK PURCHASE CLAUSE: In case successful bidder doesn't manufacture bus body as per the delivery schedule or revised (if any), prescribed in the work order/ LOI/Procurement Contract, RSRTC reserves the right to manufacture bus body from alternate source even without giving any notice to bus body fabricator / Successful Bidder and in that event, the difference in built price and the contracted price any other expenses as applicable at the time of manufacturing, will be recovered from the bus body fabricator / Successful Bidder.

13. PENALTY CLAUSE:

- (a) **Buses shall be strictly supplied after fabrication of bus body** within a period of 40 days time after release order **and subsequent amendment (if any). In case of delay in supplying the fabricated bus, the penalty @Rs 2000 + GST (as applicable) per day per chassis/ bus. The save days on any chassis due to early delivery of bus bodies can be adjusted to a maximum of 10 days. As regards save days on any chassis due to early delivery of bus bodies earned later on will not be adjusted against the early with held amount against the later delivery of buses.**
- (b) The contractor will be obliged to complete and deliver the chassis mounted with the bus body duly completed in all respects with all accessories as provided in the broad specifications and drawings, as per AIS 052 at the given destination/ depot of RSRTC, Jaipur, within the specified period. In case the work is not completed by the Contractor within the stipulated time period or if the body building work is not carried out to the entire satisfaction of the Authorized Representative of the Corporation, the Managing Director, RSRTC shall have the powers to revoke the Agreement and withdraw the chassis from the custody of the Contractor after giving 7 days notice.

In the event of such withdrawal, the Contractor shall not be entitled to claim any compensation from the Corporation for the incomplete or defective work done as also for the material used by him for the incomplete fabrication work or for the withdrawal of the chassis. If the Corporation decides to withdraw bare / incomplete fabricated bus body with chassis, then the liquidated damages as specified below will be levied upon the Contractor from the date of issue of release Order.

From the date of issue of release order to handover/withdrawl of chassis / incompletely fabricated bus body to RSRTC.	Rs. 2000 + GST per day per bus
---	--------------------------------



- (c) The damages @ Rs.2000/- +GST per day per chassis besides actual traveling expenses required to be incurred by the Inspector during to and fro journey to the Contractor's premises shall be payable by the Contractor if the vehicle is not ready for inspection at a particular stage for which an intimation has been given to the Corporation.
- (d) RSRTC reserves the right to recover any penalty, risk purchase amount, sample failure recovery or any other pending liabilities of the bidder/ successful bidder after serving a written 7 days notice, from any of the pending dues/security deposits with RSRTC. In case the pending dues/security deposits are not sufficient then the same shall be recoverable from the Contractor's movable and immovable property by RSRTC under the Public Demands Recovery Act.
- (e) The corporation will be at liberty to cancel the allotment and forfeit the Bid Security of the Contractor if the chassis are not lifted within 7 days from the date of issue of Release Order.
- (f) Any defects occurs in warrenty period, Contractor shall attend the defects at RSRTC Depots within 5 days after intimation of RSRTC via email / letter. If the reported defects are not removed within a period of 05 days by the contractor, 10% Performance Security Deposite of such vehicles shall be forfeited without giving any further notice. In addition to the recovery of extra expenditure incurred by the corporation against removal of defects, such extra amount shall be recovered out of total Performance Security Deposite of the body builder

14. SERVICE OF NOTICE:- Any notice required to be given under any of the foregoing clause shall be deemed to have been given and served if sent to the Fabricaror Successful Bidder by registered Post/Speed Post/Courier/e-mail at the address given in the Bid or at any other address subsequently notified by the bus body fabricator / Successful Bidder. In case of undelivered, RSRTC will not be responsible for same.

15. CORRESPONDENCE: All correspondence with RSRTC would be done directly by the Bidder /its authorized representative only. Correspondence through agents or unauthorized representatives will not be allowed.

16. FORCE MAJEURE:

- (i) "Force Majeure" or "Force Majeure Event" shall mean occurrence in India of any or all of the following events, if it affects the performance by the Bidder claiming the benefit of Force Majeure (the "Affected Party") of its obligations under this Bid Document and which act or event
 - A. is beyond the reasonable control of the Affected Party,
 - B. the Affected Party could not have prevented or overcome by exercise of due diligence and following good industry practice, and
 - C. has material adverse effect on the Affected Party:
 - a) act of God, epidemic, extremely adverse weather conditions, lightning, earthquake, landslide, cyclone, flood, volcanic eruption, chemical or radioactive contamination or ionising radiation, fire or explosion;
 - b) strikes or boycotts interrupting supplies and services to the Project for a continuous period of 24 (twenty four) hours and an aggregate period exceeding 7 (seven) days in an year;
 - c) any judgment or order of any court of competent jurisdiction or statutory authority made against the Bidder in any proceedings for reasons other than failure of the Bidder to comply with any applicable law;



- d) an act of war (whether declared or undeclared), invasion, armed conflict or act of foreign enemy, blockade, embargo, riot, insurrection, terrorist or military action, civil commotion or politically motivated sabotage;
 - e) industry-wide or State-wide strikes or industrial action for a continuous period of 24 (twenty four) hours and exceeding an aggregate period of 7 (seven) days in an year;
 - f) any event or circumstance of a nature analogous to any of the foregoing.
- (ii) Upon occurrence of a Force Majeure Event, the Affected Party shall by notice report such occurrence to RSRTC forthwith.
- (iii) No Breach of Contract

The failure of a Party to fulfill any of its obligations under the contract shall not be considered to be a breach of, or default under the Procurement Contract so far as such inability arises from an event of Force Majeure, provided that the party affected by such an event (a) has taken all reasonable precautions, due care and reasonable alternative measure order to carry out the terms and conditions of this contract, and (b) has informed other party as soon as possible about the occurrence of such an event but not later than 7 calendar days.

(iv) Extension of Time

Any period within which a party shall, pursuant to the Procurement Contract, complete any action or task, shall be extended for a period equal to the time during which such party was unable to perform such action as a result of Force Majeure. The delivery period mentioned in work order may be extended upon occurrence of a Force Majeure event. The Bidder shall be required to give notice within 7 days to this corporation in writing in his claim for an extension of the delivery period. After receipt of such notice and verifications; if necessary the delivery period will be extended but without prejudice to other terms and conditions of the work order and Procurement Contract's conditions. If the Successful Bidder, does not deliver the ordered material even after expiry of extended delivery period then RSRTC will be entitled to recover liquidated damages from the bus body fabricator.

17. GOVERNING LAW: This Bid Document shall be governed by and interpreted in accordance with the **laws of India.**

18. CONFIDENTIALITY: In addition to the requirements of the provisions of Section 49 of the RTPP Act 2012 and Rule 77 of the RTPP Rules 2013 regarding 'Confidentiality', the successful Bidder/ bus body fabricator shall keep confidential all information in relation to the Procurement Contract and shall not, without the written consent of RSRTC, divulge to any third party any information whether proprietary or otherwise, any documents, data, or other information furnished directly or indirectly to RSRTC in connection with the Procurement Contract.

19. NON-RESPONSIVENESS OF BID: RSRTC may return or reject the Bid, including but not limited to the following events:

1. RSRTC reserves the right to reject the entire or part of any Bid without assigning any reason, whatsoever. The documentation submitted by the Bidders shall not be returned in case their Technical Bid is not acceptable.
2. The Financial Bid or its contents thereof are found in the Technical Bid.
3. Incomplete or erroneous Bid has been submitted.



4. RSRTC reserves the right at its sole discretion not to award the contract to any of the Bidders. This decision does not commit RSRTC to pay any costs or loss incurred in the preparation and submission of any requisite Bid by the Bidders.
5. If the Bidder deliberately gives wrong information in its Bid, RSRTC reserves the right to reject such Bid at any stage or to cancel/ revoke the procurement contract, if awarded, and to forfeit the Bid Security Deposit or the Performance Security, as applicable.
6. The Bidder must follow all the terms and conditions and instructions in the Bid Document. If the Bidder fails to follow any of the terms and conditions and instructions of the Bid Document, its Bid is liable for rejection.
7. Canvassing in any form in connection with the Bids is strictly prohibited and the Bids submitted by the Bidders who resort to canvassing will be liable for rejection.

20. DISQUALIFICATIONS: Even though the Bidder meets the qualifying criteria, they could be disqualified even after declared successful bidder, if they have:

- i. Made misleading or false representations in the forms, statements and attachments submitted in proof of the qualification requirements.
- ii. Where the Bidder has already submitted the Bid and is a member of the entity which has already submitted the Technical Bid/ Bid or vice versa.
- iii. If any such information which would have entitled RSRTC to reject or disqualify the Bidder, becomes known after the Bidder has been pre-qualified. RSRTC reserves the right to cancel the pre-qualification of the Bidder at any later stage, without assigning any reason thereof.
- iv. Where the Bidder is a consortium firm or an entity of similar nature.
- v. Bidders who canvass or attempt to influence the pre/post-qualification or selection process shall necessarily be disqualified from the Bidding process at any stage.
- vi. Any entity which has been barred by Government of India/any State Government or any of its agencies in last three financial year i.e. 2020-21,2021-22, 2022-23 from participating in the Bidding process or otherwise and the bar subsists as on the date of submission of Technical Bid, would not be eligible to submit any Technical Bid.

21. TERMINATION OF PROCUREMENT CONTRACT

- (I) **TERMINATION FOR DEFAULT:** RSRTC may, without prejudice to any other remedy under the provision of the RTPP Act 2012, the RTPP Rules 2013 or the Procurement Contract, for breach of Procurement Contract, by notice of default sent to the Successful Bidder, may terminate the work order/ Procurement Contract.
- (II) **TERMINATION FOR INSOLVENCY:** RSRTC may at any time terminate the work order/ Procurement Contract by giving notice to the Successful Bidder if the Successful Bidder becomes a subject of corporate insolvency resolution process. In such event, termination will be without compensation to the Successful Bidder, provided that such termination will not prejudice or affect any right of action or remedy that has accrued or will accrue thereafter to RSRTC.
- (III) If the Successful Bidder goes into liquidation whether compulsory or voluntary, through any means, suffers on account of execution of a decree or compounds with the creditors for the settlement of his debts, and the corporation can rescind the contract at the cost and risk of the contractor. RSRTC shall thereupon have the authority to enter into a fresh contract with any other contractor / person, firm company for the completion of the same and recover the losses arising on such account from contractor in a manner deemed fit



22. DISPUTE RESOLUTION & ADJUDICATION

(I) **DISPUTE RESOLUTION:** Any dispute or difference whatsoever arising between the parties out of or relating to the construction, meaning, scope, operation or effect of this contract or the validity or the breach thereof, shall in the first instance, be resolved by referring such dispute or difference to the Standing Committee constituted vide Rajasthan State Road Transport Corporation's office order No.HO/Law/Gen/17/781 dated 03.10.2017. The Standing Committee so constituted shall ensure full compliance with the office order referred to above. The standing committee as per above order of RSRTC will consist of: -

- i) Chairman & Managing Director/ Managing Director –Chair Person)
- ii) Financial Advisor
- iii) Concerned HOD
- iv) Executive Director (Law)
- v) Officer in charge of concerned department - Member Secretary. (Not below the rank of Dy.GM)

Officer in Charge after receiving the claim petition along with 2% fees of claim amount from the claimant will submit the petition to the Standing Committee. The standing committee will pass the decision based on the claim and documents produced by both the parties and decision so passed by the standing committee will be conveyed to both the parties by the member secretary of the committee.

(II) **ADJUDICATION:** Any dispute/objection regarding the conditions mentioned in all the tenders/contracts/agreements issued by the corporation shall be filed in the competent court located in Jaipur.

23. EXECUTION OF AGREEMENT

A. (1) A procurement contract shall come into force from the date on which the letter of acceptance or letter of intent is dispatched to the bidder.

(2) The successful bidder shall sign the procurement contract within a period specified in the bidding document or where the period is not specified in the bidding document then within fifteen days from the date on which the letter of acceptance or letter of intent is dispatched to the successful bidder.

(3) If the bidder, whose bid has been accepted, fails to sign a written procurement contract or fails to furnish the required performance security within specified period, the procuring entity shall take action against the successful bidder as per the provisions of the Act and rules of RPPP. The procuring entity may, in such case, cancel the procurement process or if it deems fit, offer for acceptance the rates of lowest or most advantageous bidder to the next lowest or most advantageous bidder, in accordance with the criteria and procedures set out in the bidding documents.

(4) The bidder shall be asked to execute the agreement on a non judicial stamp of specified value of Rupees 500 or as per stamp act at its cost.

B. AT THE TIME OF EXECUTION OF AGREEMENT:

The Bus body Fabricator shall pay performance security as per clause 3 of section IX in favor of FA RSRTC JAIPUR at the time of execution of this Agreement.

24. WORK ORDER:

On the completion of necessary formalities of Agreement / Contract and after signing of the same by both parties, the Corporation will issue detailed work order indicating number of chassis to be allotted to the Contractor in pursuance of this Agreement / Contract.



25. MISCELLANEOUS:

- (a) The material required by the Contractor for the bus body fabrication shall be arranged by the Contractor. The Corporation will not be responsible for arranging any articles/ material as may be required for the purpose.
- (b) The contractor shall be required to execute a Trust bond on the stamp of Rs 500 in the format given by RSRTC at the time of receiving of chassis.(ANNEXURE “R”)
- (c) The Authorized Signatory of the RSRTC shall be entitled to order to permit any deviation from the Broad Specifications given by the Corporation and the Contractor shall abide by such instructions. However, in case of deviations having been made without prior approval, then the decision for reducing the cost to that extant shall be taken by the RSRTC which shall be final and binding by the Contractor.
- (d) The Contractor shall dispatch the vehicles to the RSRTC HEAD-OFFICE, JAIPUR communicated to him with a copy of the 2nd / Final stage inspection report, gate pass and bill in TRIPLICATE along with TRC and shall furnish the GRs from the HEAD-OFFICE, RSRTC, JAIPUR along with the bill (including ORIGINAL COPY) , gate pass and all other neccasary documents required by transport department for registration of buses shall be submitted to the office of the General Manager (B/B) by the bus body fabricator.
if any changes come in law or in CMVR so bidder/body fabricator must comply with govt. rules / laws. In case of non-registration due to any reason of certification of body fabrication then losses will be borne by bus body fabricator.
- (e) In case of strike or any labour problem or closure of the factory, the Contractor will immediately inform of the same to RSRTC. The authorized representative shall have the authority to withdraw all or any of the chassis from the custody of the Contractor. In the event of such withdrawals, the Corporation would be entitled for imposing the suitable penal provisions on the Contractor under the clause of the Agreement
- (f) The contractor shall be fully responsible for the maintenance and safe custody of the chassis as long as the chassis remain in the Contractor’s premises. It is further agreed that contractor will return the chassis after fabrication of bus bodies in the same condition in which it was delivered to them. In case any damage occurred in chassis during fabrication of bus bodies, contractor shall be wholly responsible for the same and the amount of damage shall be recovered from the bus body builder.
- (g) In the event of non fulfillment of any of the terms and conditions of this Agreement, the RSRTC shall be at liberty to terminate the contract without assigning any reason to the Contractor. In the event of termination of the contract, the Corporation shall be entitled to retrieve the chassis, tools etc. entrusted to the Contractor for Body Building. The contractor shall hand over the same to the Corporation immediately on demand without putting any counter claim on his failure to do so. The contractor would be obliged to allow the Authorized Representative of the Corporation to enter into the premises where these articles are stored and to take their possession.
- (h) The contractor shall not assign or sublet the contract of any part thereof to any other person.
- (i) The contractor shall fully indemnify the Corporation against any action claim or costs, charges and expenses arising out of any infringement or alleged infringement of letters, patent, design trade mark, make of copy right or any other protected right in respect of any machine, plant, work material or any system or method of using, fixing working or for any other arrangement, used or filed or supplied by the Contractor.
- (j) If the contractor declares insolvency or enter into liquidation whether compulsory or voluntary but for the liquidation for the purpose of the reconstruction or suffer an execution for the debt to be levied against him or compounds with the creditors for the settlement of his debts, the RSRTC would require the assigned work to be completed and if this requisition is not satisfactorily complied with, within 7 days from the date of his notice, the Managing



Director, RSRTC may issue a notice to the contractor in writing to rescind the contract at the cost and risk of contractor. The M.D., RSRTC shall thereupon have the authority to enter into a fresh contract with any other person, firm or company for the completion of the same without prejudice to his right to recover the losses from the Contractor's PERFORMANCE SECURITY DEPOSIT etc. Any losses or damages for the default of the contract and the losses sustained by the corporation on account of damages under the contract shall be recovered in all possible manners.

- (k) Nothing under the contract clauses contained shall debar the Corporation from recovering the losses from the Contractor by suit or by other means, such extra costs, shall also be recovered from the Contractor.
- (l) Any legal proceedings arising between the Corporation and the contractor if it is a must shall be instituted in the Courts situated in JAIPUR CITY alone and not anywhere else in the country.
- (m) The contractor shall be provide one front and one rear wind screen glass template (frame).
- (n) Bidder may also visit RSRTC depots for reference of same type of bus for more clarification/design.



SECTION X: VARIOUS FORMATS

ANNEXURE “A”

TECHNICAL BID APPLICATION

To
The General Manager (B/B)
Rajasthan State Road Transport Corporation
Head Office, Parivahan Marg,
JAIPUR-302 001.

Sub: Fabrication of bus bodies for **3X2 super express blue line** Passenger Buses as per specifications of RSRTC

Ref: NIB No -----

- a) We declare that we fulfill the qualification criteria in conformity with the Bidding Document and offer to supply in accordance with the specifications,
- b) We have examined and have no reservations to the Bidding Document,
- c) Our Bid shall be valid for a period of **90** days from the last date of bid submission and it shall remain binding upon us and may be accepted at any time before the expiration of this period,
- d) If our Bid is accepted, we commit to submit a Performance Security in the amount of **10%** of the order value or shall submit the Performance Security Declaration, as per rule No.75 of RTPP Act 2012 & Rule 2013 as the case may be, for the due performance of the purchase order/contract;
- e) Our firm, including any subcontractors or suppliers for any part of the work order /contract, have nationality of India,
- f) We are not participating, as Bidder in more than one Bid for Fabrication of bus bodies in this bidding process,
- g) We will provide evidence of continued eligibility satisfactorily to the procuring entity, at the procuring entity request during period of contract,
- h) Our firm have not been debarred by the State Government or RSRTC for any part of this Contract,
- i) We understand that this Bid/LOI/work order shall constitute a binding contract between us, until a formal Contract is prepared and executed,
- j) We understand that RSRTC is not bound to accept the lowest evaluated bid or any other bid that RSRTC may receive,
- k) We agree to permit the Procuring Entity to seek clarification/pending documents relating to the bid submission,
- l) We declare that we have complied with and shall continue to comply with the provisions of the Code of Integrity including Conflict of Interest as specified for Bidders in the RTPP Act, 2012, RTPP Rules, 2013 and this Bidding document during the procurement process and execution of the purchase order till completion of all our obligations under the Contract.
- m) We are also submitting our financial bid for fabrication of super express – Blue line type bus bodies with passenger bus seats on chassis having wheel base 5100 mm to 5500 mm as per drawings and specifications of RSRTC and BUS CODE accreditation certificate AIS 052. We understand that corporation reserves the right to reject any application without assigning any reason.
- n) We hereby also submit that we carefully read all the terms, conditions, specifications & instructions mentioned in this Bid documents and we ensure to comply with the same and we have BUS CODE accreditation certificate AIS 052 or prevailing bus body code for fabrication of above type of bus bodies

Bid Authorized Signatory Person’s Name: _____ In
the capacity of (Designation): _____ Signed: _____
Date: _____ Duly authorized to sign the Bid for and on behalf of (Firm’s
Name) _____ PAN No. _____ ROC No. _____ Complete
Address _____ Telephone/Mob No.: _____ E-
mail: _____ We wish to apply.

Stamp & Signature



ANNEXURE ‘B’

Declaration by the Bidder

In relation to our Bid submitted to[enter designation and address of the procuring entity] for procurement of [insert name of the Goods] in response to their Notice Inviting Bids No..... Dated we here by declare that:

1. Declaration by the Bidder under Section 7 and 11 of the Act

- i. We are eligible and possess the necessary professional, technical, financial and managerial resources and competence required by the Bidding Document issued by the Procuring Entity.
- ii. We have fulfilled our obligation to pay such of the taxes payable to the Central Government or the State Government or any local authority, as specified in the Bidding Document.
- iii. We are not insolvent, in receivership, bankrupt or being wound up, not have our affairs administered by a court or a judicial officer, not have our business activities suspended and are not the subject of legal proceedings for any of the foregoing reasons.
- iv. We do not have, and our directors and officers not have, been convicted of any criminal offence related to our professional conduct or the making of false statements or misrepresentations as to our qualifications to enter into a procurement contract within a period of three years preceding the commencement of this procurement process, or not have been otherwise disqualified pursuant to debarment proceedings.
- v. We do not have a conflict of interest as specified in the RTPP Act & Rules and this Bidding Document, which materially affects fair competition.

We have complied and shall continue to comply with the Code of Integrity as specified in the RTPP Act & Rules, and this Bidding Document, till completion of all our obligations under the Contract.

2. Declaration by Bidder (For not being blacklisted/debarred)

We, the undersigned declare that our firm have not been blacklisted by any of STU’s/Govt. of India / State Government/ Public sector undertaking for breach of contract.

3. Declaration by Bidder (For not being bankruptcy and insolvent)

We, the undersigned declare that our firm have not been Bankruptcy /insolvent by any of Govt. bank / private bank during last three financial year 2021-22, 2022-23, 2023-24 and current financial year.

If above declarations are found to be incorrect then without prejudice to any other action that may be taken, my/ our Bid Security may be forfeited in full and the Bid if any to the extent accepted may be cancelled.

Signed: _____

Name: _____

In the capacity of: _____

Duly authorized to sign the Bid for and on behalf of: _____

Date: _____

Tel: _____ Fax: _____ e-mail: _____

Date:

Place:

Signature of Bidder:

Name:

Designation:

Address:



ANNEXURE “C”

Compliance with the code of integrity and No conflict of interest

Any person participating in procurement process shall,-

- (a) not offer any bribe, reward or gift or any material benefit either directly or indirectly in exchange for an unfair advantage in procurement process or to otherwise influence the procurement process;
- (b) not misrepresent or omit information that misleads or attempts to Omislead so as to obtain a financial or other benefit or avoid an obligation;
- (c) not indulge in any collusion, bid rigging or anticompetitive behavior to impair the transparency, fairness and progress of the procurement process;
- (d) not misuse any information shared between the procuring entity and the bidders with an intent to gain unfair advantage in the procurement process;
- (e) not indulge in any coercion including impairing or harming or threatening to do the same, directly or indirectly, to any party or to its property to influence the procurement process;
- (f) not obstruct any investigation or audit of a procurement process;
- (g) disclose conflict of interest, if any; and
- (h) disclose any previous transgressions with any entity in India or any other country during the last three years or any debarment by any other procuring entity.

Conflict of Interest:

The bidder participating in a bidding process must not have a conflict of interest.

A conflict of interest is considered to be a situation in which a party has interests that could improperly influence that party’s performance of official duties or responsibilities, contractual obligations, or compliance with applicable laws and regulations.

- (i) A Bidder may be considered to be in conflict of interest with one or more parties in a bidding process if, including but not limited to:-
 - (a) have controlling partners/ share holders in common; or
 - (b) receive or have received any direct or indirect subsidy from any of them; or
 - (c) have the same legal representative for purposes of the bid; or
 - (d) have a relationship with each other, directly or through common third parties, that puts them in a position to have access to information about or influence on the bid of another bidder or influence the decisions of the procuring entity regarding the bidding process; or
 - (e) the bidder participates in more than one bid in a bidding process. Participating by a bidder in more than one bid will result in the disqualification of all bids in which the bidder is involved. However this does not limit the inclusion of the same sub contractor, not otherwise participating as a bidder, in more than one bid; or
 - (f) The bidder or any of its affiliates participated as a consultant in the preparation of the design or technical specifications of the goods, works or Services that are the subject of the bid; or
 - (g) Bidder or any of its affiliates has been hired (or is proposed to be hired) by the procuring entity as engineer - in – charge/ consultant for the contract.



ANNEXURE “D”

Bid Security format in case of Bank Guarantee

(to be issued by a Scheduled Bank)

Bid Security (Bank Guarantee Unconditional)

Form of Bid Security

[insert Bank's Name, and Address of Issuing Branch or Office]

Beneficiary: [insert Name and Address of Procuring Entity]

Date: [insert date]

BANK GUARANTEE No.: [insert number]

We have been informed that **[insert name of the Bidder]** (here in after called "the Bidder") has submitted to you its bid dated **[insert date]** (here in after called "the Bid") for the execution of **[insert name of contract]** under Notice Inviting Bids No. **[insert NIB number]** ("the NIB"). Furthermore, we understand that, according to your conditions, bids must be supported by a bid security. At the request of the Bidder, we **[insert name of Bank]** here by irrevocably undertake to pay you any sum or sums not exceeding in total an amount of ----- **[insert amount in figures][insert amount in words]** upon receipt by us of your first demand in writing accompanied by a written statement stating that the Bidder is in breach of its obligation(s)

- (a) has withdrawn or modified its Bid after deadline for submission of bids, during the period of bid validity specified by you in NIB or
- (b) having been notified during the period of bid validity specified in the BDS, about the acceptance of its Bid by you,
 - (i) failed or refused to execute the Contract Agreement within the time period specified in the NIB, or
 - (ii) failed or refused to furnish the performance security, in accordance with GCC within the time period, or
- (c) has breached a provision of the Code of Integrity specified in the RTPP Act, RTPP Rules and the ITB.

This guarantee will expire: (a) if the Bidder is the successful Bidder, upon our receipt of copies of the contract signed by the Bidder and the performance security issued to you upon the instruction of the Bidder; and (b) if the Bidder is not the successful Bidder, upon the earlier of

- (i) our receipt of a copy of your notification to the Bidder of the name of the successful Bidder; or
- (ii) thirty days after the expiration of the validity of the Bidder's bid. Consequently, any demand for payment under this guarantee must be received by us at the office on or before that date. Signed: _____

[insert signature of person whose name and capacity are shown]

Name: _____

[insert complete name of person signing the Bid Security]

In the capacity of: _____

[insert legal capacity of person signing the Bid Security]

Duly authorized to sign the Bid Security for and on behalf of

[insert name of the Bank]

Dated on day of, **[insert date of signing]** Bank's Stamp _____ **[affix Stamp of the Bank]**



Annexure “E”

Grievance redressal during procurement process:

- (A) The Designation and Address of First Appellate Authority is **Managing Director**, RSRTC, Parivahan Marg, Chomu House, Jaipur
- (B) The Designation and Address of Second Appellate Authority is **Chairman**, RSRTC, Parivahan Marg, Chomu House, Jaipur.
- (C) In case, the Chairman, RSRTC and Managing Director, RSRTC is held by same person then first appellate authority will be **Chairman & Managing Director**, RSRTC and second appellate authority will be **Board of Directors**, RSRTC.

1. Filing an appeal :-

If any Bidder or prospective bidder is aggrieved that any decision, action or omission of the procuring Entity is in contravention to the provisions of the Act or the Rules or the Guidelines issued thereunder, he may file an appeal to First Appellate Authority, as specified in the Bidding Document within a period of ten days from the date of such decision or action, omission, as the case may be, clearly giving the specific ground or ground on which the feels aggrieved;

Provided that after the declaration of the Bidder as successful the appeal may be filed only by the Bidder who has participated in procurement proceedings;

Provided further that in case a Procuring Entity evaluates the Technical Bids before the opening of the financial Bids, an appeal related to the matter of Financial Bids may be filed only by the Bidder whose Technical Bid is found to be acceptable.

- 2. The officer to whom an appeal is filed under para (1) shall deal with the appeal as expeditiously as possible and shall endeavor to dispose it of within thirty days from the date of the appeal.
- 3. If the officer designated under para (1) fails to dispose of the appeal filed within the period specified in para (2), or if the bidder or prospective bidder or the procuring entity is aggrieved by the order passed by the first appellate authority, the bidder or prospective bidder or the procuring entity, as the case may be, may file a second appeal to second appellate authority specified in the bidding document in this behalf within fifteen days from the expiry of the period specified in para (2) or of the date of receipt of the order passed by the first appellate authority, as the case may be.

4. Appeal not to lie in certain cases:

No appeal shall lie against any decision of the procuring entity relating to the following matters, namely:-

- (a) Determination of need of procurement.
- (b) Provisions limiting participation of bidders in the bid process.
- (c) The decision of whether or not to enter in to negotiations.
- (d) Cancellation of a procurement process.
- (e) Applicability of the provisions of confidentiality.

5. Form of appeal

- (a) An appeal under para (1) or (3) above shall be in annexed form along with a many copies as there are respondents in the appeal.
- (b) Every appeal shall be accompanied by an order appealed against, if any, affidavit verifying the facts stated in the appeal and proof of payment of fee.
- (c) Every appeal may be presented to first appellate authority or second appellate authority, as the case may be, in person or through registered post or authorized representative.

6. Fee for filing appeal

- (a) Fee for first appeal shall be rupees two thousand five hundred and for second appeal shall be rupees ten thousand, which shall be non-refundable.
- (b) The fee shall be paid in the form of bank demand draft or banker's cheque of a Public Sector Bank in India payable in the name of appellate authority concerned.



7. Procedure for disposal of appeal.

- (a) The first appellate authority or second appellate authority, as the case may be, upon filing of appeal, shall issue notice accompanied by copy of appeal, affidavit and documents, if any, to the respondents and fix date of hearing.
- (b) On the date fixed for hearing the first appellate authority or second appellate authority, as the case may be, shall-
 - (i) Hear all the parties to appeal present before him, and
 - (ii) Peruse or inspect documents, relevant records or copies thereof relating to the matter.
- (c) After hearing the parties, perusal or inspection of documents or relevant records or copies thereof relating to the matter, the appellate authority concerned shall pass an order in writing and provide the copy of order to the parties to appeal free of cost.
- (d) The order passed under sub-clause (c) above shall also be placed on the state public procurement portal.



FORM No. 1

[See rule 83]

Appeal under the Rajasthan Transparency in Public Procurement Act, 2012

Appeal Noof

Before the (First / Second Appellate Authority)

1. Particulars of appellant:

- (i) Name of the appellant:
- (ii) Official address, if any:
- (iii) Residential address:

2. Name and address of the respondent(s):

- (i)
- (ii)
- (iii)

3. Number and date of the order appealed against and name and designation of the officer / authority who passed the order (enclose copy), or a statement of a decision, action or omission of the RSRTC in contravention to the provisions of the Act by which the appellant is aggrieved:

4. If the Appellant proposes to be represented by a representative, the name and postal address of the representative:

5. Number of affidavits and documents enclosed with the appeal:

6. Grounds of appeal:

.....

.....

..... (Supported by an affidavit)

7. Prayer:

.....

.....

Place

Date

Appellant's Signature



Annexure “F”

Additional Condition of Contract

(1) Correction of arithmetical errors

Provided that a Financial Bid is substantially responsive, the Procuring entity will correct arithmetical errors during evaluation of Financial Bids on the following basis:

- (i) if there is a discrepancy between the unit price and the total price that is obtained by multiplying the unit price and quantity, the unit price shall prevail and the total price be corrected, unless in opinion of the Procuring entity there is an obvious misplacement of the decimal point in the unit price, in that case the total price as quoted shall govern and the unit price shall be corrected;
- (ii) if there is an error in a total corresponding to the addition or subtraction of subtotals, the subtotals shall prevail and the total shall be corrected ; and
- (iii) If there is a discrepancy between words and figures, the amount in words shall prevail, unless the amount expressed in words is related to an arithmetic error, in which case the amount in figures shall prevail subject to (i) and (ii) above.

If the Bidder that submitted the lowest evaluated Bid does not accept the correction of errors, its Bid shall be disqualified and its Bid Security shall be forfeited or its Bid Securing Declaration shall be executed.

(2) Procuring Entity’s Right to Vary Quantities

- (i) If the Procuring Entity does not procure any subject matter of procurement or procures less than the quantity specified in the Bidding Documents due to change in circumstances, the Bidder shall not be entitled for any claim or compensation.
- (ii) Orders for extra items may be placed by RSRTC, up to 5% of the value of the original contract. The fair market value of such extra items payable by the RSRTC to the contractor shall be determined by the RSRTC.
- (iii) Orders for additional quantities may be placed, on the rates and conditions given in the contract. If the original order was given after inviting open competitive bids. Delivery or completion period may also be proportionately increased. The limits of order for additional quantities shall be 50% of the value of the goods and services of the original contract. In exceptional cases and without changing the scope of work envisaged under the contract, RSRTC may procure additional quantities beyond 50% of the quantity of the individual items as provided in the original order, the additional quantities so procured shall be part and parcel of the work being executed and the limit of 50% of value of original contract shall not be exceeded in any case.

(3) Dividing quantities among more than one bidder at the time of award (In case of procurement of goods)

As a general rule all the quantities of the subject matter of procurement shall be procured from the bidder, whose bid is accepted. However, when it is considered that the quantity of the subject matter of procurement to be procured is very large and it may not be in the capacity of the bidder, whose bid is accepted, to deliver the entire quantity or when it is considered that the Subject matter of procurement to be procured is of critical and vital nature, in such cases, the quantity may be divided between the bidder, whose bid is accepted and the second lowest bidder or even more bidder in that order, in a fair, transparent and equitable manner at the rates of the bidder, whose bid is accepted.



ANNEXURE “G”

**Format of Bank Guarantee for 10% Performance Security
Performance Security**

(to be given by a Scheduled Bank)

..... **[Bank's Name, and Address of Issuing Branch or Office]**

Beneficiary: **[Name and Address of Procuring Entity]**

Date:

Performance Guarantee No.:

We have been informed that **[Name of the bus body fabricator]**
..... (here in after called "the bus body fabricator ") has entered into Contract No/PO/LOI.
..... **[reference number of the Contract]** dated with you, for the supply
of **[Name of contract and brief description of the Goods and Related Services]**
..... (here in after called "the Contract").

Furthermore, we understand that, according to the conditions of the Contract, a performance security is required.

At the request of the Contractor, we **[Name of the Bank]** hereby
irrevocably undertake to pay you any sum or sums not exceeding in total amount of Rupees*
..... **[amount in figures]** (Rupees..... **[amount in words]**
.....) such sum being payable upon receipt by us of your first demand in writing
accompanied by a written statement stating that the Contractor is in breach of its obligation(s) under the
Contract/PO/LOI, without your needing to prove or to show grounds for your demand or the sum
specified therein. The Guarantor agrees to extend this guarantee /Warranty for a specified period in
response to the Procuring Entity's written request for such extension for that specified period, provided
that such request is presented to the Guarantor before the expiry of the guarantee/ Warranty.

This guarantee shall expire, no later than the Day of **, and any demand
for payment under it must be received by us at this office on or before that date.

Stamp of Bank and Authorized Signature(s)

* **The Guarantor shall insert an amount representing the percentage of the Contract Price
specified in the Contract**

** **Insert the date Six months after the expected completion date, including period of
Warranty/ Guarantee and maintenance period, if any.**

Notes:

- 1. The Procuring Entity should note that in the event of an extension of the time for
completion of the Contract, the Procuring Entity would need to request an extension of
this guarantee from the Guarantor. Such request must be in writing and must be made
prior to the expiration date established in the guarantee.**



ANNEXURE “H”

Authority Letter

(To be given in the letter head of Bus body Fabricator)

Date:

I/We the Bus body Fabricators of _____
authorize Mr./Mrs. _____ our representative to sign the bidding
documents of Procurement Process of RSRTC. Mr./ Mrs. _____ is also authorized to
attend meetings and submit technical and commercial bid as required by procuring entity in the course
of processing of e tender Procurement Process.

(Name & Signature of authorized signatory)

(Name & Signature on behalf of Bus body Fabricator with Stamp)



ANNEXURE – "I"

DETAILS OF BIDDER ORGANIZATIONAL SET UP & ADDRESSES OF FACTORY

1.	Name of applicant	
	Applicant Father's name	
	Residence Address	
	Telephone No.	
	Fax No.	
	Mobile No.	
	E-mail address	
2	Name of the firm In case of the Joint venture, the name of the lead firm)	
3	Head-Office Address	
	Telephone No.	
	Mobile No.	
	E-mail address	
4	Regional Office Address (If any)	
	Telephone No.	
	Mobile No.	
	E-mail address	
5	Factory/ Works Address	
	Telephone No.	
	Mobile No.	
	E-mail address	
6	Local Office Address in India (If any)	
	Telephone No.	
	Mobile No.	
	E-mail address	
7	i. Description of Applicant (e.g. fabrication of coaches.	
	ii. In House facilities available. (for	



	design/ supply/ quality assurance.)	
8	Year of incorporation (attach copy of certificate of registration)	
9	Name and address of Bankers	
10	Name (s) and address(s) of Principals of Companies to be associated in the project and whether parent/ subsidiary etc.	
11	Attach the copy of Bus body code accreditation certificate AIS-052 for fabrication of such buses.	

Note:

1. Applicant covers proprietary firm, partnership, Limited company or Corporation, Joint Venture.
2. Particulars of item 2 to 9 above should be furnished separately for each partner of Joint Venture.



ANNEXURE – "J"
FINANCIAL TURNOVER STATUS

(To be given separately for each constituent firm of Joint Venture)

1. Name of Applicant (in case of Joint Venture, the names of the constituent firms)
2. Turnover of bus body fabrication works undertaking last 3 financial years and projected turnover for the current year.

(Rupees in lacs)

2023-24	2022-23	2021-22

Note:

All items should be properly filled in. Where any particular item is not applicable, it should be clearly mentioned as "Not applicable".



ANNEXURE-"K"

FACTORY AREA AND PLANT & MACHINERY

Name of the Applicant	M/s

1. SHED:

a) FACTORY AREA:

- i. Top cover with flooring
- ii. Top cover without flooring
- iii. Without shed and flooring

2. PRESS BRAKES AVAILABILITY (PLEASE MENTION CAPACITY:

I)

II)

3. SHEARING MACHINE:

- a) Capacity
- b) Thickness

4. WELDING EQUIPMENT:

S. No.	Type	Capacity	Nos.
a.	Mig		

5. AIR COMPRESSOR:

Nos. of air compressors	
Available and their capacity	

6. DG Set No. Capacity

7. BENDING AND SLOTTING MACHINE:

- a) Hand operated
- b) Machine operated.



8. PAINTING SYSTEM TYPES:

- a) Close
- b) Open
- c) Paint baking

9.

Riveting arrangement	No. of machinery available
a) Pneumatic riveting	

10. Firefighting equipment.

11. Battery chargers:

Capacity of battery charge to charge the batteries at a time.	
---	--

12. Water leakage test arrangements:

a	Shower testing of complete vehicle at a time
b	Car washer testing.

13. Tyre inflating arrangement.

14. Panel stretching machine availability and their capacity details of:

15. Suitable fixtures for bending of roof sticks , pillars etc.

16. Portable drill machine , grinders and other hand tools .

17. Roof panel rolling machine

18. Dry film thickness measuring equipments, gloss measuring equipments .

19. Measurement Devices

- (a) Hardness (Brinell , rock well)
- (b) Paint thickness
- (c) Micrometer
- (d) Vernier Calipers
- (e) Any other , if required

Note :-

1. Any other equipment which may be available, may please be provided, for Constructions of quality of Body Building.



ANNEXURE -'L'

WORKING EXPERIENCE & PRODUCTION CAPACITY

(TO BE GIVEN SEPARATELY FOR EACH CONSTITUENT FIRM OF JOINT VENTURE)

Name of the Applicant	M/s

1. Experience of fabrication of passenger bus bodies (More than 22 seater) in Number of years.....

2. Nos. and type of bus body fabricated in last three financial year.

Period	Type of bus bodies	For RSRTC	For Other STUs/ Government Institutes
2021-22			
2022-23			
2023-24			

3. Maximum bus body building capacity (Maximum number of chassis that may be given to bus body fabricator for bus body fabrication per Month) of 3X2 SUPER EXPRESS BLUE LINE for RSRTC per month (capacity should not be less than 150 Nos. per month)



ANEXXURE – "M"
INFORMATION REGARDING LITIGATION/ DEBARRING/
EXPELLING OF BID

1.

A	Is the applicant currently involved in any Litigations/ arbitration relating to the contract works.	Yes / No
B	If yes, give details: [. With RSRTC [. With others.	

2.

A	Has the applicant or any of its constituent partners been debarred / expelled by any Agency in India, during last 3 years.	Yes / No
B	If yes, give details:	

3.

A	Has the applicant or any of its constituent partners failed to perform on any contract work in India during last 3 years.	Yes / No
B	If yes, give details:	

Note:

If any information in this schedule is found to be incorrect or concealed, pre-qualification application may be rejected.



ANNEXURE-"N"
JOINT VENTURE DATA

1.	Name of applicant		
2	Head-Office Address		
		Telephone No.	
		Mobile No.	
	Fax No.		
	E-Mail Address		
3	Local/ Regional Office Address (If any)		
		Telephone No.	
		Mobile No.	
	Fax No.		
	E-Mail Address		
4	Name of partners	a)	
		b)	
		c)	
		d)	
		e)	
		Details about constituent firms to be provided on separate sheet.	
5	Name (s) if lead firm	a)	
		b)	
6	Joint venture Agreement	a) Date of Agreement	
		b) Place	
7	Proposed distribution of responsibilities among constituent firms.	a) Financial distribution	
		b) Work distribution	



ANNEXURE-"O"

AFFIDAVIT

(TO BE GIVEN SEPARATELY BY EACH PARTNER OF JOINT VENTURE)

1. I, the undersigned, do hereby certify that all the statements made in the required attachments are true and correct.
2. The undersigned also hereby certifies that neither our firm M/s _____ nor any of its constituents partners have abandoned for any work on any State Transport Undertaking or Govt institute in India nor any contract awarded to us for such works has been rescind during last 3 years prior to the date of this bid.
3. The undersigned hereby authorize (s) and request (s) any bank, person, firm or corporation, to furnish pertinent information deemed necessary and requested by the department (RSRTC) to verify this statement or regarding our competence and general reputation.
4. The undersigned understands and agrees that further qualifying information may be requested, and agrees to furnish any such information at the request of the department/ projection implementing agency.

(Signed by an Authorized Officer of the firm.)

(Title of the Officer)

(Name of the firm)

Date



ANNEXURE- “P” Declaration by the Bidder regarding Qualifications

Declaration by the Bidder

In relation to my/our Bid submitted to for procurement of , in response to their Notice Inviting Bids No DatedI/we hereby declare under Section 7 of Rajasthan Transparency in Public Procurement Act, 2012, that:

1. I/we possess the necessary professional, technical, financial and managerial resources and competence required by the Bidding Document issued by the Procuring Entity;
2. I/we have fulfilled my/our obligation to pay such of the taxes payable to the Union and the State Government or any local authority as specified in the Bidding Document;
3. I/we are not insolvent, in receivership, bankrupt or being wound up , not have my/our affairs administered by a court or a judicial officer, not have my/our business activities suspended and not the subject of legal proceedings for any of the foregoing reasons;
4. I/we do not have, and our directors and officers not have, been convicted of any criminal offence related to my/our professional conduct or the making of false statements or misrepresentations as to my/our qualifications 'to enter into a procurement contract within a period of three years preceding the commencement of this procurement process, or not have been otherwise disqualified pursuant to debarment proceedings;
5. I/we do not have a conflict of interest as specified in the Act, Rules and the Bidding Document, which materially affects fair competition;

Date:
Place:

Signature of bidder
Name:
Designation:
Address:



ANNEXURE “Q”

FINANCIAL PARAMETER SHEET

S. No.	Parameters	
1	Name & address of firm	
2	E-Mail Address for communications (for all communications to bus body fabricator)	1.
		2.
3.	Contact Number	1.
		2.
4	Supply Location	JAIPUR, RAJASTHAN
5	Validity of Bid	90 days (from the last date of Bid submission)
6	Contract period	The Period of contract shall be applicable till warranty period, however the time period for repetitive work order (Fabrication of bus bodies) shall be six months from the date of opening of technical bid
7	Bank Account Details for Payment	
a.	Name of the firm	
b.	Name of the account holder	
c.	Bank Name and Branch	
d.	Bank Account No.	
e.	IFSC Code	
f.	GST No.	
g.	PAN for TDS	
8	Bank Account Details for RSRTC	
a.	Name of the firm	RSRTC, JAIPUR
b.	Name of the account holder	RSRTC
c.	Bank Name and Branch	ICICI Bank, Parivahan Marg
d.	Bank Account No.	677405000011
e.	IFSC Code	ICIC0006774
f.	GST No.	08AABCR7187B1ZC
g.	PAN for TDS	AABCR7187B

Note: If there is any change in the Bank details, communication detail please intimate this office immediately through authorized person



ANNEXURE “R”

TRUST BOND RECEIPT

This is to confirm that we have on this day received in TRUST the following chassis worth Rs. (Rupees.....) from the Managing Director, Rajasthan State Road Transport Corporation, Jaipur.

The chassis as detailed below are held by us TRUST PROPERTY for making bus bodies thereon and shall be stored in our workshop and shall not be removed from the aforesaid premises without the consent of the Managing Director of Rajasthan State Road Transport Corporation, Jaipur.

S. No.	Make	Chassis No.	Engine No.	Type of body

We hereby undertake to return the above chassis to the Managing Director, RSRTC on demand by him and if, the chassis are required by him at any time, they shall be returned to him. However, till such time the body is built on these chassis, they shall be held by us as Trust Property on behalf of Corporation.

We hereby declare that we shall be responsible for the chassis as long as the same remain in our possession and custody and not delivered to the Managing Director, RSRTC, Jaipur. We hereby bind ourselves to indemnify the RSRTC, Jaipur in case of any loss whether by theft or otherwise of the above said chassis. Similarly we shall be responsible for any loss or damage to the chassis in question by whatever way in may occur.

We hereby further declare that, we shall be responsible for proper maintenance of batteries by "TRICKLE CHARGES" to maintain the batteries in good and serviceable condition at our cost. We shall also be responsible for the overall maintenance which will include upkeep the tyres with correct pressure, exercising brakes, prevention against formation of rust on any metal parts of the chassis, for the upkeep rubberized items and for proper lubrications of the engine and chassis.



SECTION X :-

CHECK LIST

Note :- Please (✓) the submitted documents on web site.

On the top of envelope containing bid, please write as:

TENDER ID.....

BID FOR-----DUE ON-----

Mandatory Documents to be submitted

(A) Fees

- i. Bid Document Fee in the form of DD in favour of FA RSRTC, Jaipur.
- ii. Bid Processing Fee in the form of DD in favour of Managing Director RISL, Jaipur.
- iii. Bid Security in the shape of demand draft/Bank Guarantee payable to **FA RSRTC**, Jaipur (In case of BG it should be issued from branch of Scheduled bank). (**Annexure “C”**)

Necessary Documents to be submitted

1. Each page of tender terms and conditions duly filled & signed with stamp of concerning authority.
2. All filled Annexures with Stamp & Signature.
3. Type approval certificate as per AIS052 certificate revised and amended upto date for bus body fabrication on specified chassis.
4. Bidder shall be Bus body Fabricator of Minimum 100 Nos. bus bodies in last three financial year (i.e.2021-22, 2022-23, 2023-24) for any STU or Government Department / PSU or Chassis Manufacturer/ any Private Fleet Owner who has attached buses to Govt./STU's with proof of copies of work orders and satisfactory work completion certificate from concerned.
5. Certificate of Incorporation/ Registration issued by the Registrar of Companies. In case of firm is in partnership/ proprietary, certified copy of the partnership deed may also be enclosed.
6. GST registration certificate and PAN card.
7. Audited and Certified Balance Sheet for last three financial year (2021-22, 2022-23, 2023-24) should be enclosed. Profit-Loss Account or Turnover certificate for last three financial year (2021-22, 2022-23, 2023-24) duly certified by the CA should be enclosed.
8. Self declaration certificate.
9. Insurance copy and any other required documents as mention in this bid.

Note:

- i. If any firm fails to submit any of the mandatory documents (original), then RSRTC have the right to disqualify / reject the bid.
- ii. If any firm fails to submit any of the necessary documents, then RSRTC reserve the right to disqualify that firm from bid or ask the firm to submit the remaining documents online through soft copy.
- iii. Bidders are requested to upload only necessary documents which are asked by the procuring entity. Don't upload unnecessary documents.

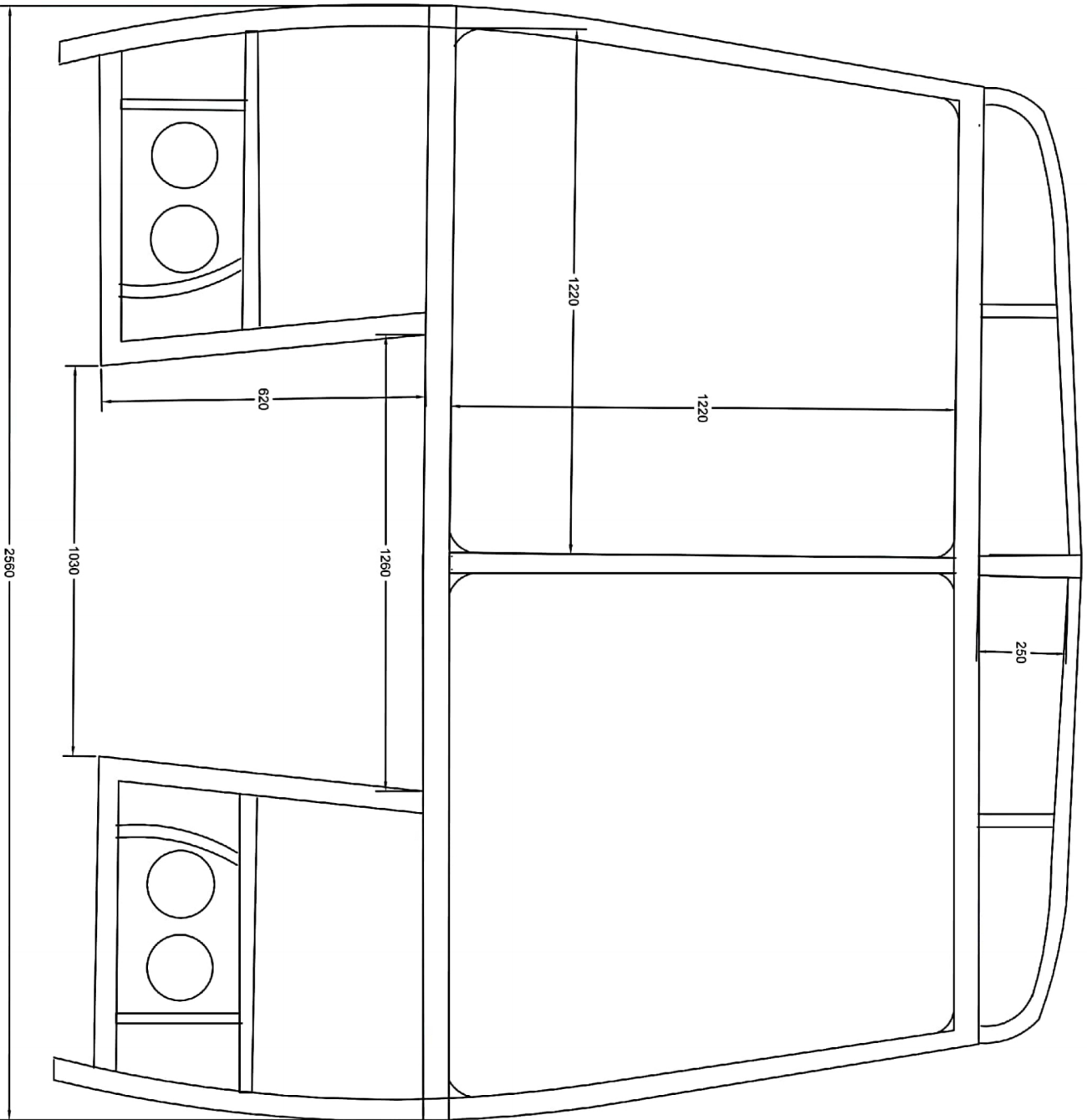

RAJASTHAN STATE ROAD TRANSPORT CORPORATION	
PARIVAHAN MARG JAIPUR	
DRAWING FOR FABRICATION OF SUPER EXPRESS- BLUE LINE BUS BODIES FOR	
BID YEAR 2023-24	
DRAWING NO. -	FRONT VIEW
DRAWN BY	
CHECKED BY	
APPROVED BY	

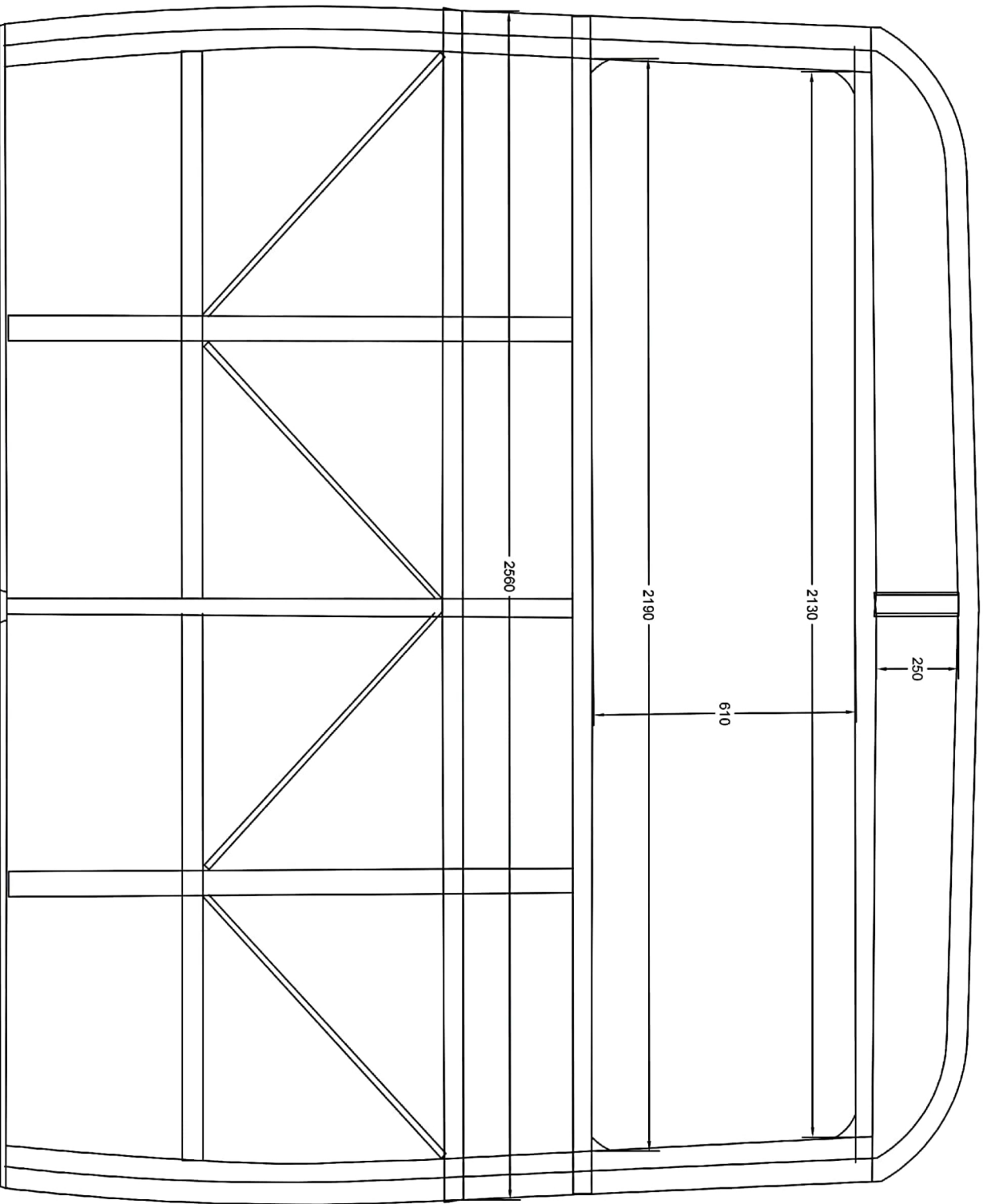

RAJASTHAN STATE ROAD TRANSPORT CORPORATION

PARIVAHAN MARG JAIPUR

DRAWING FOR FABRICATION OF SUPER EXPRESS- BLUE LINE BUS BODIES FOR

BID YEAR 2023-24

DRAWING NO. -

REAR VIEW

DRAWN BY

CHECKED BY

APPROVED BY

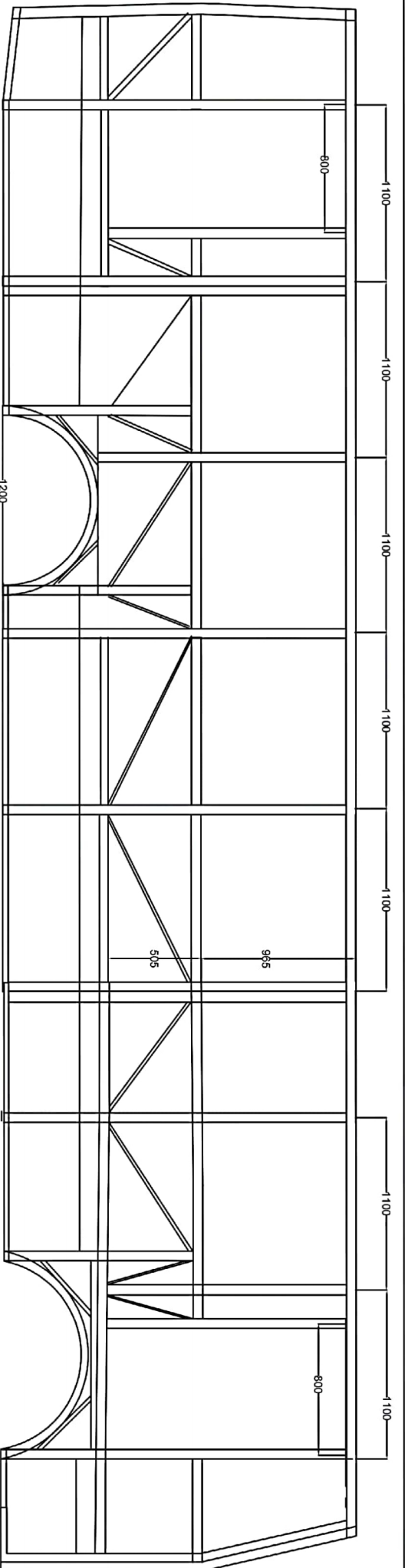

MALAYSIAN STATE ROAD TRANSPORT CORPORATION	
PARIWISAYAN MANG JAWAJUR	
DRAWING FOR FABRICATION OF SUPER EXPRESS - BLUE LINE BUS BODIES FOR BLD YEAR 2023/24	
DRAWING NO.:	SEE VIEW 9/4.5
DRAWN BY	
CHECKED BY	
APPROVED BY	

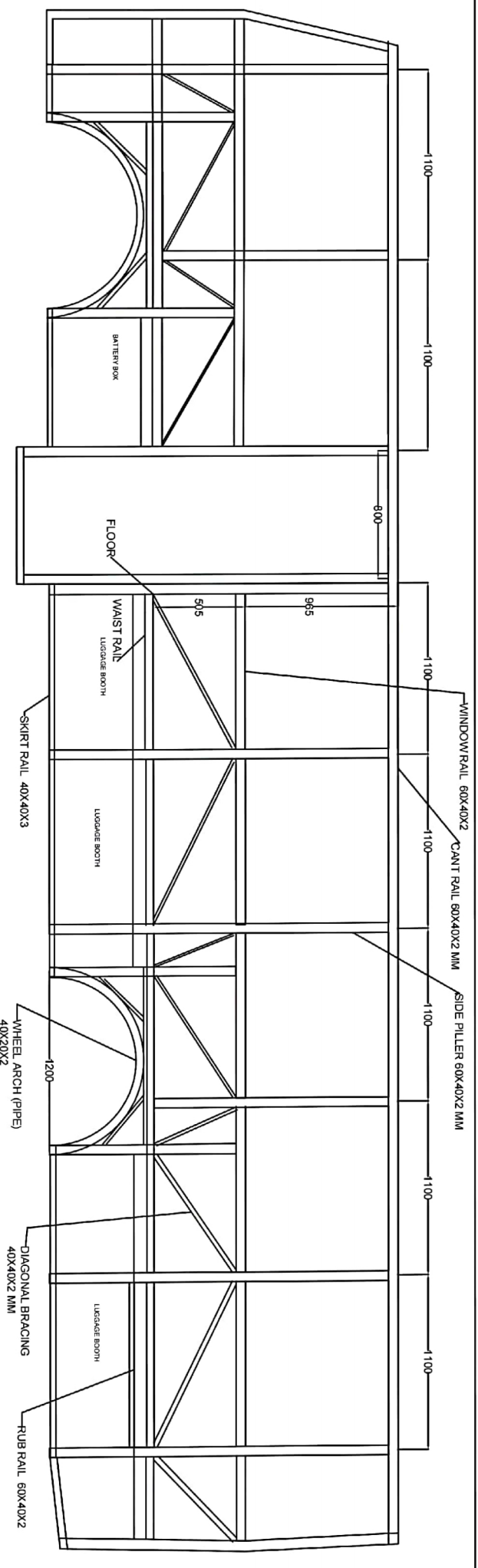

RAJASTHAN STATE TRANSPORT CORPORATION
PARIVAHAN MARG JAIPUR

DRAWING FOR FABRICATION OF SUPER EXPRESS- BLUE LINE BUS BODIES FOR BID YEAR 2023-24

DRAWING NO. -	SIDE VIEW L.H.S
DRAWN BY	
CHECKED BY	
APPROVED BY	

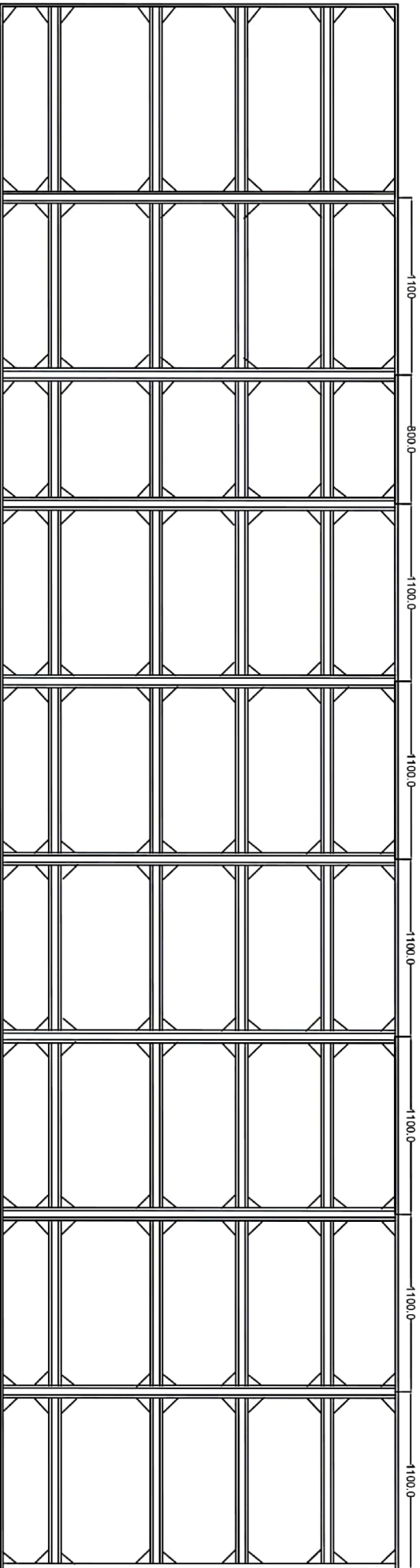

RAJASTHAN STATE ROAD TRANSPORT CORPORATION	
DRAWING OR REVISION OF SUPER EXPRESS BLUE LINE BUS BODIES FOR B.O. YEAR 2022-23	
DRAWING NO. -	ROOF STICK STRUCTURE
DRAWN BY	
CHECKED BY	
APPROVED BY	

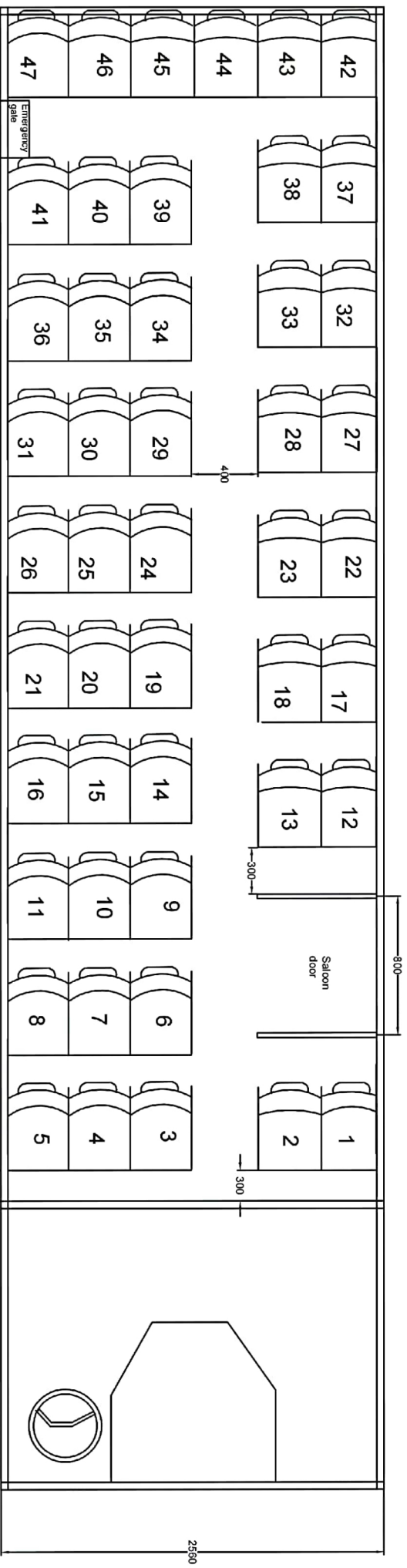

RAJASTHAN STATE ROAD TRANSPORT CORPORATION
PARIVAHAN MARG JAIPUR

DRAWING FOR FABRICATION OF SUPER EXPRESS - BLUE LINE BUS BODY:
 FOR BID YEAR 2023-24

DRAWING NO. -	SEAT LAYOUT
DRAWN BY	
CHECKED BY	
APPROVED BY	

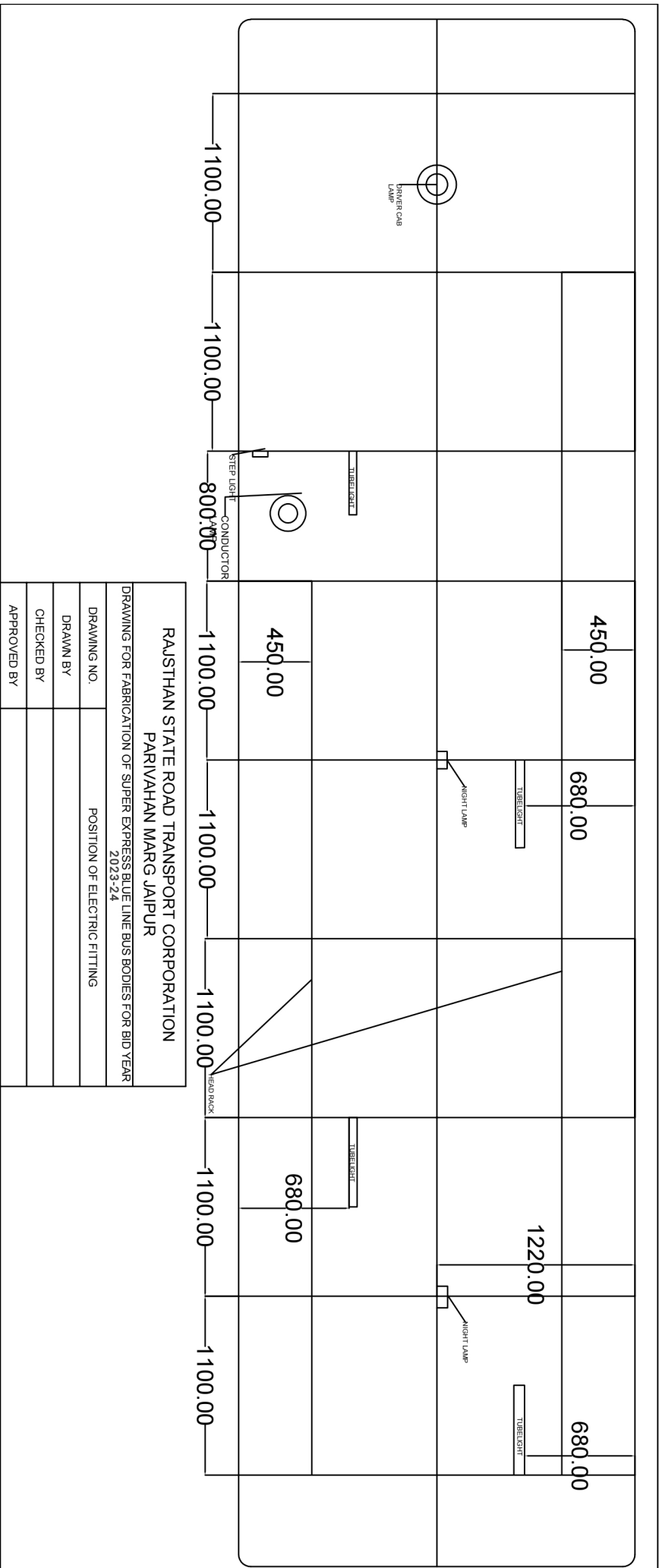

**RAJSTHAN STATE ROAD TRANSPORT CORPORATION
PARIVAHAN MARG JAIPUR**

DRAWING FOR FABRICATION OF SUPER EXPRESS BLUE LINE BUS BODIES FOR BID YEAR 2023-24

DRAWING NO.	POSITION OF ELECTRIC FITTING
DRAWN BY	
CHECKED BY	
APPROVED BY	

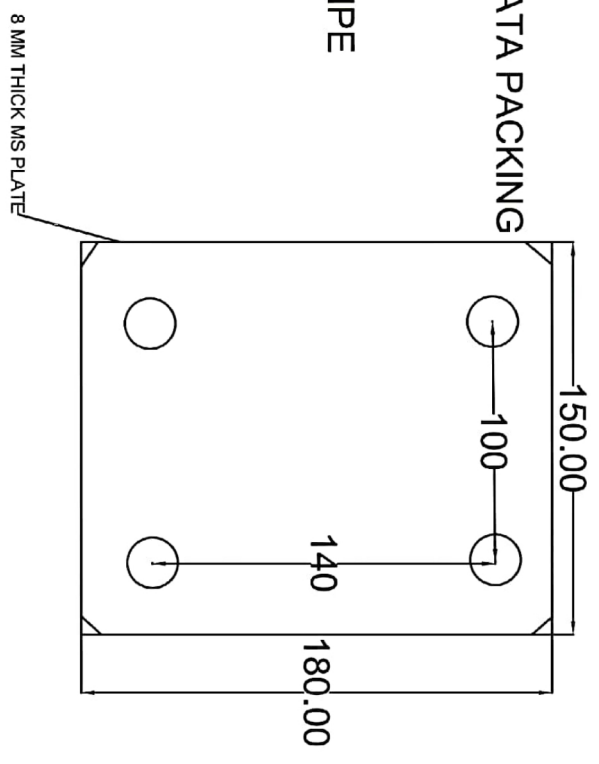
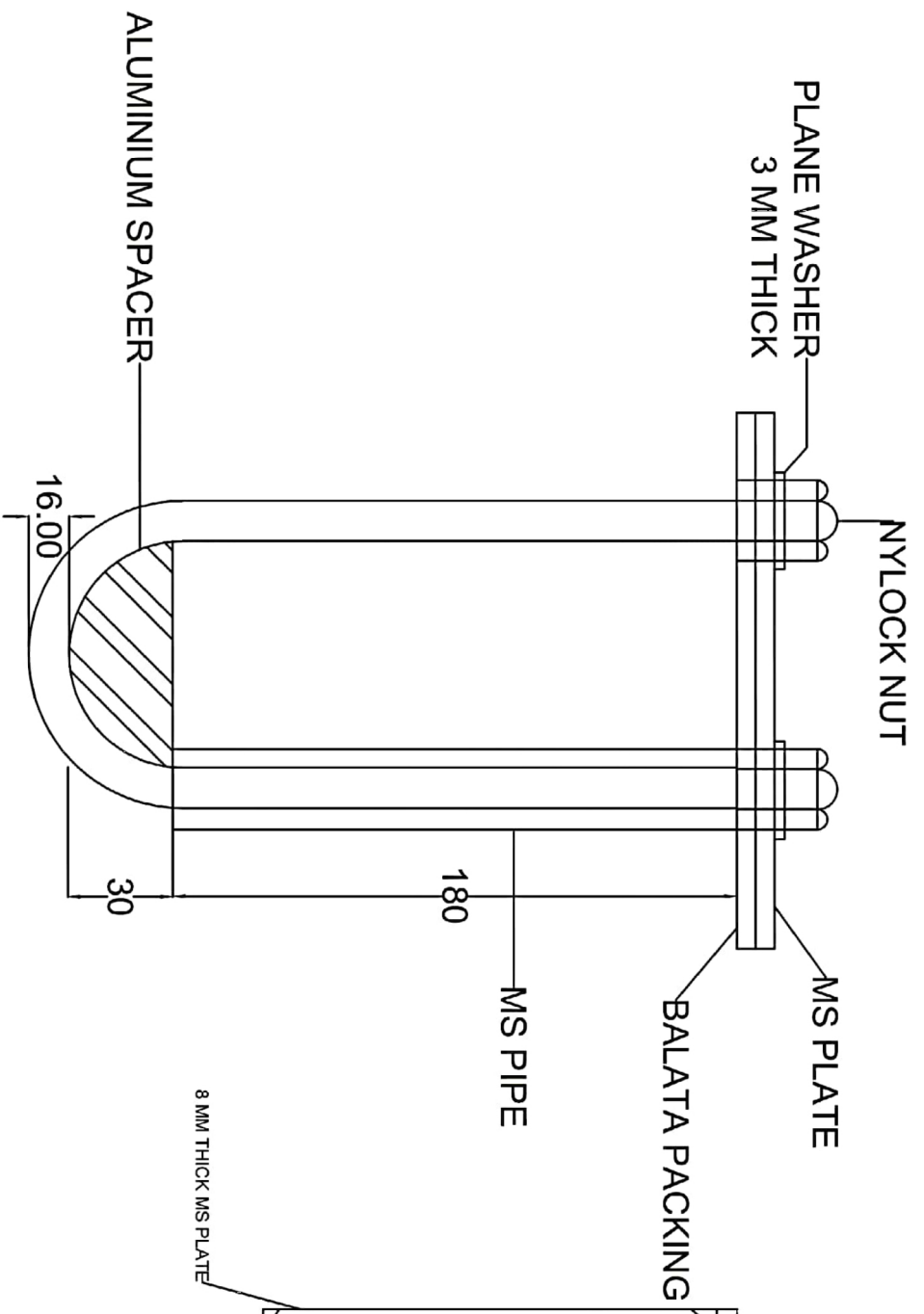

RSRTC PARIVAHAN MARG JAIPUR	
DRAWING NAME	U BOLT
DRAWN BY	
CHECKED BY	
APPROVED BY	

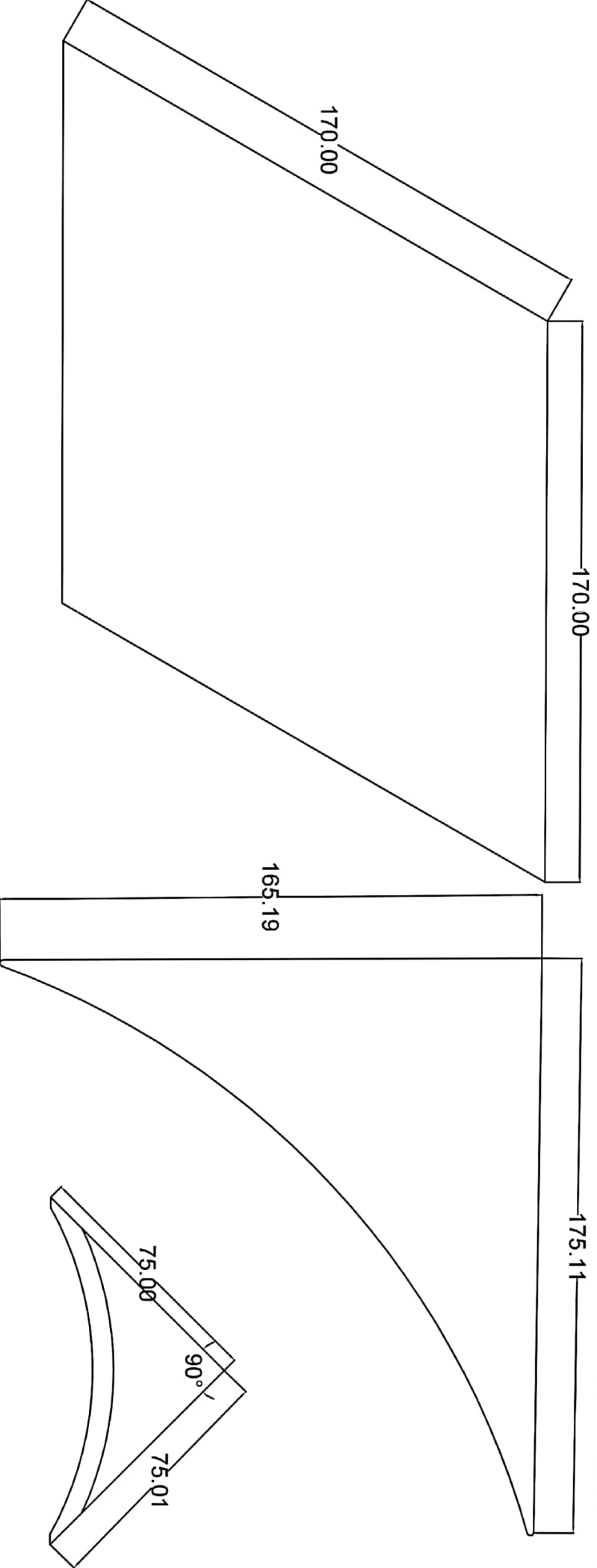

**RAJASTHAN STATE ROAD TRANSPORT CORPORATION
PARIVAHAN MARG JAIPUR**

DRAWING FOR FABRICATION OF SUPER EXPRESS BLUE LINE BUS BODIES FOR BID YEAR 2023-24

DRAWING NO.	GUSSETS
DRAWN BY	
CHECKED BY	
APPROVED BY	

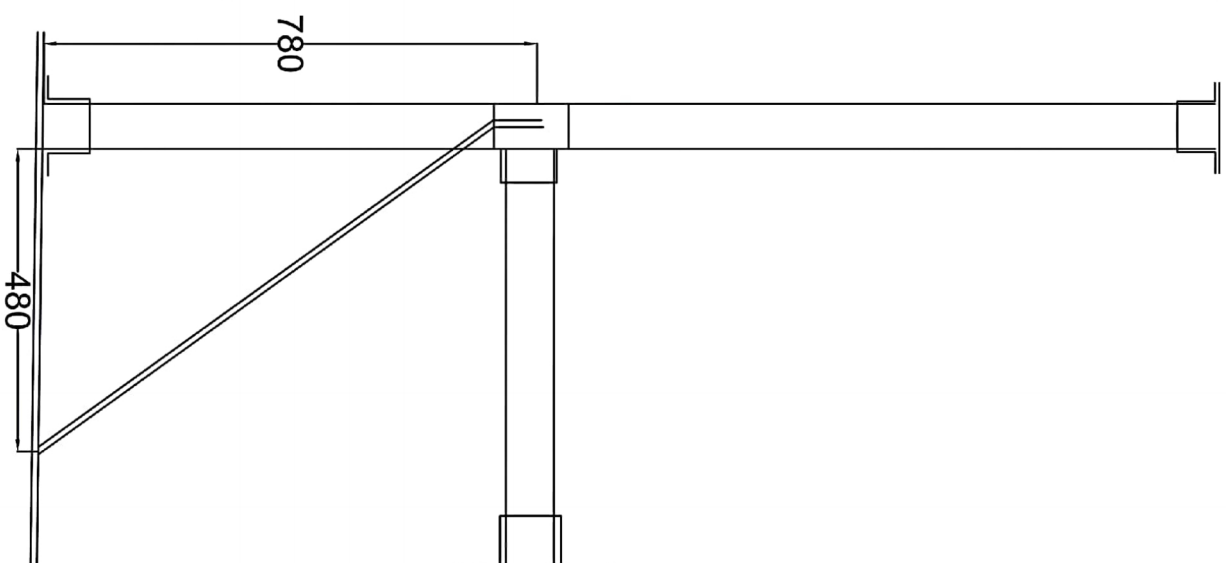

RAJASTHAN STATE ROAD TRANSPORT CORPORATION PARIVAHAN MARG JAIPUR

DRAWING FOR FABRICATION OF SUPER EXPRESS BLUE LINE BUS BODIES
FOR BID YEAR 2023-24

DRAWING NO.	PROTECTOR CUM SALOON DOOR PIPE
DRAWN BY	
CHECKED BY	
APPROVED BY	

FRONT CURVED GLASS
THICKNESS- 6MM

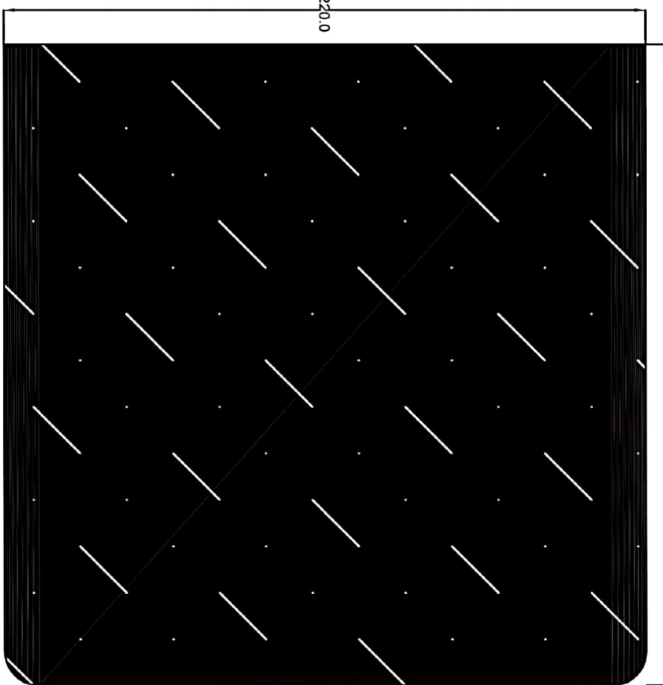

VARIOUS GLASSES

SIDE WINDOW
THICKNESS- 4.8MM

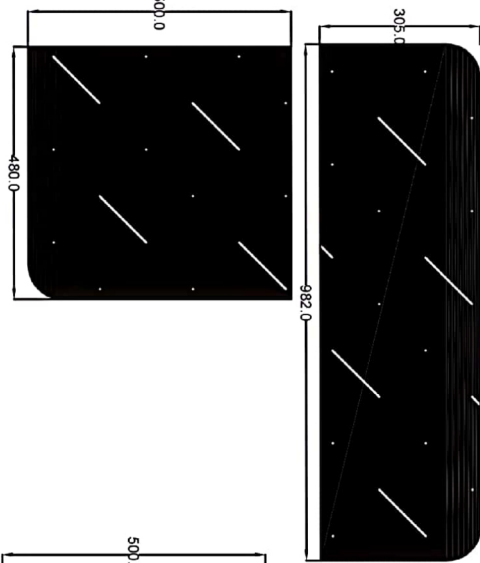

EMERGENCY WINDOW
THICKNESS- 4.8MM

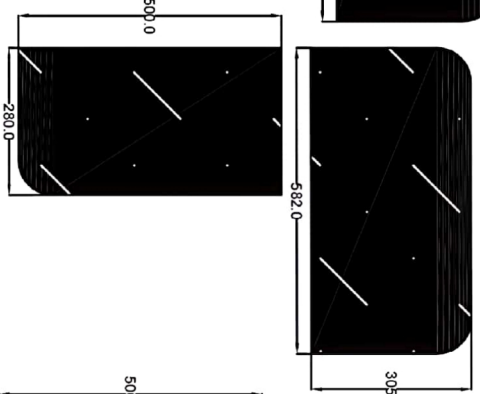

WINDOW INFRONT OF MAIN GATE
THICKNESS- 4.8MM

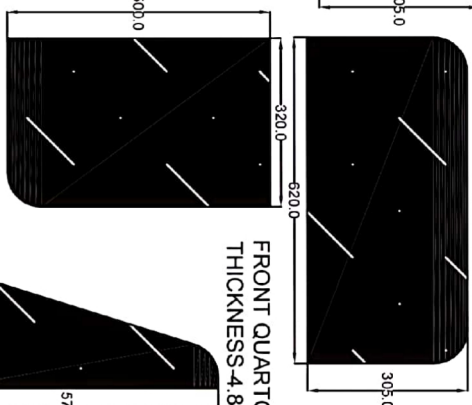

FRONT QUARTOR WINDOW
THICKNESS- 4.8 MM

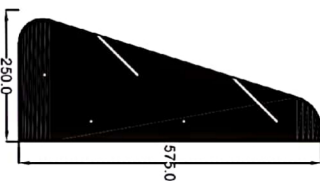

BACK GLASS
THICKNESS- 6MM

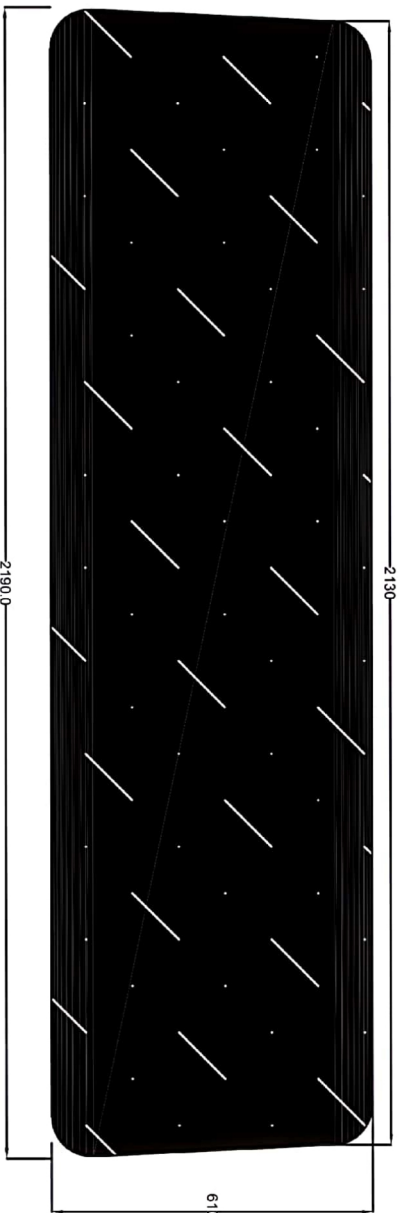

CABIN SIDE GLASS
THICKNESS- 4.8 MM

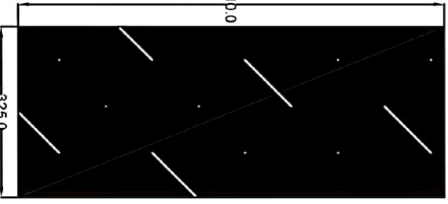

CABIN GLASS
THICKNESS- 4.8 MM

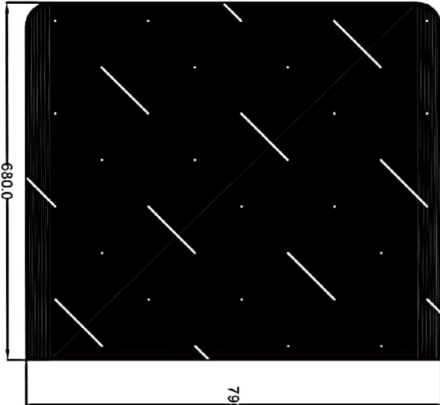

Gate glass
thickness 4.8 MM

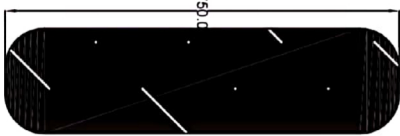

Driver back glass
thickness 4.8MM

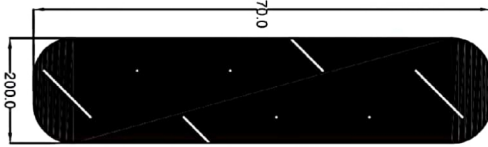

RAJASTHAN STATE ROAD TRANSPORT CORPORATION PARIVAHAN MARG JAIPUR

DRAWING FOR FABRICATION OF SUPER EXPRESS BLUE LINE BUS BODIES FOR BID YEAR 2023-24

DRAWING NO.	VARIOUS GLASSES
DRAWN BY	
CHECKED BY	
APPROVED BY	