

**Price: Rs. 500**

**REQUEST FOR PROPOSAL**

**RFP No. F.1(41)/JMRC/DCA/REVENUE/MICRO CELL-JMRC PILLARS/2015-16/06 dated : 19/01/2018**

**RFP FOR LICENSING RIGHTS FOR INSTALLATION & OPERATION OF MICRO CELL ON SELECTED PILLARS OF JAIPUR METRO VIADUCT (PHASE - 1A)**



**Jaipur Metro Rail Corporation Ltd.**

2<sup>nd</sup> Floor, RSIC Wing, Udyog Bhawan ,

CIN: U60221RJ2010SGC030630

Tilak Marg, C- Scheme, Jaipur (Rajasthan)- 302005

Website: <http://transport.rajasthan.gov.in/jmrc>

## TABLE OF CONTENTS

DISCLAIMER .....	4
1. NOTICE INVITING BIDS .....	5
1.1 INTRODUCTION .....	5
1.2 SCHEDULE TO THE INVITATION OF BIDS .....	5
1.3 ELIGIBILITY CRITERION OF BIDDERS .....	7
2. DEFINITIONS .....	8
3. INSTRUCTIONS TO BIDDERS .....	10
3.1 GENERAL INSTRUCTIONS .....	10
3.2 DUE DILIGENCE BY BIDDER .....	12
3.3 SITE VISIT AND PRE-BID CONFERENCE .....	12
3.4 CLARIFICATION / AMENDMENT / ADDENDUM .....	13
3.5 DETAILS OF MICRO CELL SPACE(S), ESTIMATED LICENSE FEES AND BID SECURITY (EMD) .....	13
3.6 COST OF BID DOCUMENT (TENDER FEE) AND E-TENDER PROCESSING FEE .....	14
3.7 BID SECURITY / EARNEST MONEY DEPOSIT (EMD) .....	14
3.8 SUBMISSION OF BID .....	15
3.9 EVALUATION OF BIDS .....	17
3.10 AWARD OF CONTRACT, SIGNING OF LICENSE AGREEMENT/ EXTENDED LICENSE AGREEMENT & SECURITY DEPOSIT .....	18
4. SPECIAL CONDITIONS OF CONTRACT (SCC) .....	21
4.1 SCOPE OF LICENSE & TECHNICAL REQUIREMENTS .....	21
4.2 PRELIMINARY PLANNING & NOTICE TO PROCEED (NTP) .....	22
4.3 ELECTRICITY PROVISIONING .....	22
4.4 HANDING OVER POSSESSION TO JMRC .....	23
4.5 OTHER TERMS & CONDITIONS .....	24
4.6 DURATION OF CONTRACT / LICENSE AGREEMENT .....	28
4.7 STATUTORY OBLIGATIONS .....	28
4.8 PAYMENT TERMS OF LICENSE FEES & ELECTRICITY CONSUMPTION CHARGES .....	30
4.9 BREACH OF CONTRACT / LICENSE AGREEMENT .....	31
4.10 TERMINATION OF CONTRACT AGREEMENT .....	32
4.11 PROHIBITED PRACTICES .....	33



4.12	CONCILIATION, ARBITRATION & JURISDICTION.....	34
4.13	FORCE MAJEURE.....	34
	ANNEXURE – I.....	36
	CHECK LIST.....	36
	ANNEXURE – II.....	38
	DECLARATION OF ACCEPTANCE OF TERMS & CONDITIONS OF THE RFP.....	38
	ANNEXURE – III.....	39
	BIDDER’S PROFILE & BID FORM.....	39
	ANNEXURE – IV.....	41
	DETAILS OF MICRO CELL SPACE(S) BID FOR AND BID SECURITY.....	41
	ANNEXURE – V.....	42
	FORMAT OF LICENSE AGREEMENT.....	42
	ANNEXURE-VI.....	45
	FORMAT FOR POWER OF ATTORNEY FOR SIGNING OF APPLICATION.....	45
	ANNEXURE-VII.....	46
	FORMAT OF FINANCIAL BID / BOQ.....	46
	ANNEXURE – VIII.....	47
	FORMAT OF BANK GUARANTEE FOR EARNEST MONEY DEPOSIT (BID SECURITY).....	47
	ANNEXURE-IX.....	50
	FORMAT OF BANK GUARANTEE FOR PERFORMANCE SECURITY DEPOSIT.....	50
	ANNEXURE-X.....	52
	FORMAT OF BANK GUARANTEE FOR INSTALLATION SECURITY DEPOSIT.....	52
	ANNEXURE-XI.....	54
	RULES & GUIDELINES FOR RELICENSE, UPKEEP & MAINTENANCE OF ELECTRICAL POWER CONNECTION IN JMRC SPACES.....	54
	APPENDIX TO ANNEXURE-XI.....	62
	ANNEXURE-XII (I).....	64
	INDICATIVE DRAWING OF METRO PILLAR.....	64
	ANNEXURE-XII (II).....	65
	INDICATIVE PHOTOGRAPHS OF METRO PILLARS WITH MICRO CELL EQUIPMENT.....	65
	ANNEXURE-XIII.....	66
	FORMAT FOR INTIMATION FOR DEPOSITION OF PAYMENTS VIA RTGS/NEFT/ECS.....	66

## DISCLAIMER

This RFP is neither an agreement nor an offer by the Authority to the prospective Bidders or any other person. The purpose of this RFP is to provide interested parties with information that may be useful to them in the formulation of their Bids pursuant to this RFP. This RFP includes statements, which reflect various assumptions and assessments arrived at by the Authority in relation to the Work. Such assumptions, assessments and statements do not purport to contain all the information that each Bidder may require. This RFP may not be appropriate for all persons, and it is not possible for the Authority, its employees or advisers to consider the objectives, technical expertise and particular needs of each party who reads or uses this RFP. The assumptions, assessments, statements and information contained in this RFP, may not be complete, accurate, adequate or correct. Each Bidder should, therefore, conduct its own investigations and analysis and should check the accuracy, adequacy, correctness, reliability and completeness of the assumptions, assessments and information contained in this RFP and obtain independent advice from appropriate sources.

The Authority, its employees and advisers make no representation or warranty and shall have no liability to any person including any Bidder under any law, statute, rules or regulations or tort, principles of restitution or unjust enrichment or otherwise for any loss, damages, cost or expense which may arise from or be incurred or suffered on account of anything contained in this RFP or otherwise, including the accuracy, adequacy, correctness, reliability or completeness of the RFP and any assessment, assumption, statement or information contained therein or deemed to form part of this RFP or arising in any way in this Selection Process.

The Authority also accepts no liability of any nature whether resulting from negligence or otherwise however caused arising from reliance of any Bidder upon the statements contained in this RFP. The Authority may in its absolute discretion, but without being under any obligation to do so, update, amend or supplement the information, assessment or assumption contained in this RFP. The issue of this RFP does not imply that the Authority is bound to select a Bidder or to appoint the Selected Bidder, as the case may be, for the Work and the Authority reserves the right to reject all or any of the Bids without assigning any reasons whatsoever.

The Bidder shall bear all its costs associated with or relating to the preparation and submission of its Bid including but not limited to preparation, copying, postage, delivery fees, expenses associated with any demonstrations or presentations which may be required by the Authority or any other costs incurred in connection with or relating to its Bid. All such costs and expenses will remain with the Bidder and the Authority shall not be liable in any manner whatsoever for the same or for any other costs or other expenses incurred by an Bidder in preparation or submission of the Bid, regardless of the conduct or outcome of the Selection Process.

## 1. NOTICE INVITING BIDS

### 1.1 INTRODUCTION

- i. Jaipur Metro Rail Corporation Limited (JMRC) is a Government of Rajasthan Undertaking, incorporated under the Companies Act, 1956, having its registered office at Khanij Bhawan, Behind Udyog Bhawan, Tilak Marg, C-Scheme, Jaipur (Rajasthan)-302005.
- ii. JMRC started its commercial operations on its first line from Mansarovar to Chandpole (Phase 1A) from 3<sup>rd</sup> June, 2015, with the mission of providing a safe, green, comfortable and fast mass rapid urban transit system to the capital city of Rajasthan.
- iii. JMRC desires to generate revenue from licensing rights for installation & operation of Micro Cells on selected pillars of Jaipur Metro viaduct (4 numbers). These Micro Cells shall be permitted to be installed at upper part of the Metro pillars and just below the collar as shown in the drawing & photograph in Annexure – XII (i) & (ii). The said Micro Cell shall offer shared solution for various types of telecom operators such as GSM/3G/4G/CDMA operators & Internet Service Providers.

### 1.2 SCHEDULE TO THE INVITATION OF BIDS

Bids are invited from eligible bidders as per schedule given here and as per terms and conditions set forth in this RFP document.

S. No.	Item	Particulars
i.	Date of Issue of RFP	18.01.2018
ii.	Websites for downloading tender Document and subsequent clarification / modification, if any	<a href="http://eproc.rajasthan.gov.in">http://eproc.rajasthan.gov.in</a> , <a href="http://www.jaipurmetrorail.in">www.jaipurmetrorail.in</a> , <a href="http://www.sppp.rajasthan.gov.in">www.sppp.rajasthan.gov.in</a> , <a href="https://transport.rajasthan.gov.in/jmrc">https://transport.rajasthan.gov.in/jmrc</a>
iii.	Cost of Bid Document (Non-Refundable)	Rs. 500 (inclusive of GST) (Rupees Five Hundred Only)
iv.	e-tender Processing Fee (Non-Refundable)	Rs. 1000 (Rupees One Thousand only)
v.	Estimated Annual Contract Amount for First Year of contract	Rs. 1,44,000 (Rs. One Lakh Fourty Four Thousand only)
vi.	Estimated Total Contract Amount for 5 Years with escalation @ 6% compounded annually	Rs. 8,11,741 (Rs. Eight Lakh Eleven Thousand Seven Hundred and Forty One only )
vii.	Earnest Money Deposit (EMD)/ Bid Security	Rs. 4,000 per pillar (Rs. 16,000 for all Four pillars)
viii.	RFP Download Start Date	19.01.2018 (1845 Hrs.)
ix.	<b>Pre-bid Conference*</b>	24.01.2018 (1130 Hrs.) at 3 <sup>rd</sup> Floor, Khanij Bhawan, Tilak Marg, C-Scheme, Jaipur
x.	Last date & time of submitting queries / seeking clarification*	29.01.2018 (2355 Hrs.)
xi.	Tentative date for replies to queries by JMRC*#	01.02.2018 (2355 Hrs.)
xii.	Online Bid submission Start Date / Time	02.02.2018 (1000 Hrs.)
xiii.	Last Date & Time of downloading of Bid Document including clarifications/ amendments, if any.	19.02.2018 (1200 Hrs.)
xiv.	Last Date & Time for Bid submission	19.02.2018 (1400 Hrs.)

S. No.	Item	Particulars
xv.	Physical submission of original DD / BC / BG for Tender fee, EMD / Bid Security and e-tender Processing Fee in JMRC office	19.02.2018 (1500 Hrs.)
xvi.	Date & Time for opening of Technical Bid	19.02.2018 (1530 Hrs.)
xvii.	Date & Time for opening of Financial Bid of Technically qualified bidders	Subsequent to Technical Bid opening (to be intimated later to the Technically qualified bidders through e-procurement portal)
xviii.	Website for Online Bid Submission	<a href="http://eproc.rajasthan.gov.in">http://eproc.rajasthan.gov.in</a> ,
xix.	Bid Validity	150 days from the last date of submission of the Bid.
xx.	Duration of Contract	Initially for Five (5) years (extendable upto 7 years).

\* The date of Pre-bid Conference and Query Submission etc. are tentative and may be changed at the discretion of JMRC. In case of any change, same will be indicated on the above mentioned websites.

# JMRC may or may not reply to the queries.

**Note:**

- i. All Technical Bids will be opened online on the specified date & time in presence of Bidders or their authorized representative who choose to attend. In the event of the date specified for bid receipt and opening being declared as a government/JMRC holiday, the due date for opening of bids will be the next working day at the same time and place or on any other day/time, as intimated by the JMRC.
- ii. Corrigendum, Addendums and subsequent clarifications on bid terms, if any, shall be uploaded on the above mentioned websites only. Keep visiting these websites for any subsequent clarifications & modifications.
  - (i) Physical Bid submission is not allowed.
  - (ii) JMRC will not be responsible for any delay in submission of online bid due to any reason.
- iii. All bidders interested to participate may contact the following officer of JMRC in case of any query:

*JGM (Revenue), JMRC,  
2<sup>nd</sup> Floor, RSIC Wing, Udyog Bhawan,  
Tilak Marg, C-Scheme, Jaipur-302005.  
Tel. No.0141- 5192407, 7728895893,  
Email: [jgmrevenue@jaipurmetrorail.in](mailto:jgmrevenue@jaipurmetrorail.in)*

### 1.3 ELIGIBILITY CRITERION OF BIDDERS

S. No.	Eligibility Criteria	Documents required to substantiate the same
i.	The bidder should be a registered firm/company.	Registration certification of the firm / Partnership deed / Certificate of incorporation, etc.
ii.	The bidder should be a Telecom Operator (UASL / GSM / CDMA / 3G / 4G) or an Infrastructure Provider (IP-I Licensee) or an Internet Service Provider (ISP) or any other service provider duly Licensed / authorised by the Department of Telecom, Govt of India for this purpose.	Valid document(s) issued by competent authority to substantiate that bidder is a Telecom Service Provider or a Registered Telecom Infrastructure Provider (IP-1 Licensee) or a ISP or any other service provider authorised by DOT, GoI.
iii.	Bidder should neither be a black listed firm nor should its contracts been terminated / foreclosed by any company / government department / public sector organisation during last 3 financial years ending 31.03.2017 and during current financial year till date of bid submission, due to non-fulfilment of Contractual obligations.	A self-declared certificate to this effect, signed by authorised signatory of the bidder company/ firm in the Bid profile (Annexure-III).
iv.	The bidder should have experience of carrying out work of similar nature of installation and operation of such installations on at-least 1 metro/ railway/ other similar pillars, anywhere within India.	Self attested list of similar installation(s) executed/ being operated in India.

You are requested to submit your Proposal as per the terms and conditions set forth in this RFP document.

**Executive Director (Corp. Affairs)**

## 2. DEFINITIONS

In this RFP, the following expressions shall have the meaning stated herein unless repugnant to the context or meaning thereof:

- **“Agreement”** or **“License/Licence Agreement”** means the Contract / Licence/License Agreement to be executed between JMRC and successful bidder, subsequent to the Letter of Acceptance as per the format at Annexure- V;
- **“Addendum/Amendment”** means any written amendment / addendum / corrigendum to this RFP, from time to time issued by JMRC to the prospective bidders;
- **"Applicant(s)/Bidder(s)"** means interested bidder(s) submitting a Proposal pursuant to this RFP;
- **“Authority”** means Jaipur Metro Rail Corporation;
- **“Bid”** shall mean a valid, final and binding offer, which includes the Technical Documents and Financial Proposal, EMD and other documents submitted by a bidder in response to and on the terms and conditions contained in this Bid Document / RFP.
- **“Bid Document”** shall mean this RFP document, including all - attached hereto and any addenda issued in accordance with the terms hereof.
- **"Bidder Authorization"** shall mean the authorization to the person signing the bid as per Annexure VI - Power of Attorney in favour of the person signing the bid.
- **“GCC”** shall mean General Condition of Contract of JMRC available on JMRC website, [www.jaipurmetrorail.in](http://www.jaipurmetrorail.in)
- **“JMRC/JMRCL/ Jaipur Metro/ Corporation/ Metro”** means Jaipur Metro Rail Corporation;
- **"Jaipur Metro Phase 1A"** means the Jaipur Metro Phase 1A - from dead end of Mansarovar Station to Chandpole Metro Station (including Mansarovar depot) (approx. 9.6 KMs).
- **"Letter of Acceptance (LoA)"** means the written notice issued by JMRC to the selected bidder(s) intimating the acceptance of selected bidder's Proposal for the award of Contract.
- **"Licensee”** shall mean the successful bidder with which JMRC signs license / License agreement for the Micro Cells in furtherance to this bidding process;
- **“License Fee”** means the amount payable by the Licensee to JMRC as per rates offered by the selected bidder for utilization of licensed space for installation and operation of Micro Cell equipment on selected pillars this RFP and accepted by JMRC to be paid by the Licensee along with other charges and any kind of GST, local levies, statutory dues, etc. that may be payable by the Licensee as per prevalent law.
- **“Permits” shall mean and include** all applicable statutory, environmental or regulatory licenses, authorization, permits, consents, approvals, registrations and franchises from concerned authorities.
- **"Proposal(s)"** shall mean a valid, final and binding offer comprised of Technical Proposal, Financial Proposal, Earnest Money Deposit and other documents as required under this RFP to be part of the bid/proposal submitted by the respective bidders, in response to and on the terms and conditions contained in this RFP;



- **“NTP”** means notice to proceed i.e., letter to be given to successful bidder for starting its operations subsequent to signing of agreement pursuant to this RFP;
- **“RFP”** means this ‘Request for Proposal’ for leasing of installation and operation of Micro Cell equipment on selected pillars space pursuant to this RFP;
- **“SHE Manual”** means Safety, Health and Environment Manual of JMRC available on JMRC website, [www.jaipurmetrorail.in](http://www.jaipurmetrorail.in)
- **“Space(s)/Micro Cell Space(s)”** means the spaces identified/ planned/ used for installation & operation of Micro Cell equipment on selected pillars pursuant to this RFP;

### 3. INSTRUCTIONS TO BIDDERS

#### 3.1 GENERAL INSTRUCTIONS

- i. This RFP (Request For Proposal) Document and any addenda thereto, together with any further communications are issued for the purpose of inviting bids only. The bidder shall not disclose any information contained in the documents or otherwise supplied in connection with this bid invitation to any third party except for the purpose of preparing his Bid. The bidder shall maintain complete confidentiality till the Contract is awarded. In the event that such confidentiality is breached, the JMRC may reject the Bid.
- ii. The bidders are advised to explicitly read this RFP document, addendum /corrigendum /clarification issued, if any, as available on state e-procurement website <https://eproc.rajasthan.gov.in>, Corporation's website [www.jaipurmetrorail.in](http://www.jaipurmetrorail.in), <https://transport.rajasthan.gov.in/jmrc> & state procurement portal [www.sppp.rajasthan.gov.in](http://www.sppp.rajasthan.gov.in) and General Condition of Contract (GCC) & SHE Manual, available on Corporation's website [www.jaipurmetrorail.in](http://www.jaipurmetrorail.in) and/or <https://transport.rajasthan.gov.in/jmrc> before submitting the Bid. By submitting the Proposal, the bidder agrees to all the points explicitly included in the scope of License & all other terms & conditions mentioned in the RFP, GCC & SHE Manual.
- iii. Each bidder will be deemed to have inspected the sites, the surroundings and inspected all necessary documentation and made all inquiries, prior to participating in the bid process.
- iv. If any change/addition/deletion is made by the bidder in the RFP document and if the same is detected at any stage even after the award of the Contract / execution of License agreement, full Earnest Money Deposit/Security Deposit will be forfeited and the contract will be terminated at the risk and cost of the bidder/Licensee.
- v. Alterations or overwriting, if any, should be avoided. However, if there are any, should be legible and signed by the bidder alongside such alterations or overwriting. However, whitener should not be used for any alterations.
- vi. Bids received after the last date and time for depositing Bid shall not be considered. Bids sent by fax, post or e-mail will not be considered.
- vii. If some of the document/annexure(s) is/are missing, the Corporation has the right to reject the Bid as invalid Bid.
- viii. The proposal shall not contain any conditional offer or discount etc. Bids containing such offers will be summarily rejected.
- ix. Bids complete in all respects must be submitted online not later than the date and time indicated therein. JMRC may, at its discretion, extend this deadline for the submission of Bids by amending the RFP Document and in that case all rights and obligations of JMRC and the bidders previously subject to the original deadline shall thereafter be subject to the deadline as extended.
- x. The bidder will be bound by the details furnished by it to JMRC while submitting the Bid or at subsequent stage. In case any of such documents furnished by it is found to be false at any

stage, it would be deemed to be a breach of terms of contract making it liable for legal action besides termination of License.

- xi. JMRC may at its sole discretion and at any time during the processing of Bid, disqualify any bidder from the Bidding process if the bidder has :–
    - a. Made misleading or false representations in the forms, statements and attachments submitted in proof of the eligibility requirements.
    - b. If found to have a record of poor performance such as abandoning works, not properly completing the contract, inordinately delaying completion, being involved in litigation or financial failures, etc.
    - c. Submitted Bid document, which is not accompanied by required documentation and Earnest Money Deposit (EMD) is non-responsive.
    - d. Fails to provide clarifications related thereto, when sought.
  - xii. JMRC, at its sole discretion and without incurring any obligation or liability, reserves the right, at any time, to;
    - a. suspend and /or cancel the bidding Process and/ or amend and/ or supplement the bidding Process or modify the dates or other terms and conditions relating thereto;
    - b. consult with any bidder in order to receive clarification or further information;
    - c. retain any information and/ or evidence submitted to the JMRC by, on behalf of, and/ or in relation to any bidder; and/ or
    - d. Independently verify, disqualify, reject and/ or accept any and all submission or other information and/ or evidence submitted by or on behalf of any bidder.
  - xiii. It shall be deemed that by submitting the bid, the bidder agrees and reLicense the JMRC, its employees, agents and advisers, irrevocably, unconditionally, fully and finally from any and all liability for claims, losses, damages, costs, expenses or liabilities in any way related to or arising from the exercise of any rights and/ or performance of any obligations hereunder, pursuant hereto and / or in connection herewith and waives any and all rights and / or claims it may have in this respect, whether actual or contingent, whether present or future.
  - xiv. No further discussion /interface will be held with the bidders whose bids have been Rejected/ Disqualified / Technically Disqualified.
  - xv. Any Bid not accompanied by valid Earnest Money Deposit (Bid Security), e-tender processing fee and the cost towards Bid document, in acceptable form will be liable to be treated as being non-responsive.
  - xvi. At any time prior to the deadline for submission of Bid, JMRC may, for any reason, whether at its own initiative or in response to clarifications requested by a bidder, modify the Bidding Document by the issuance of addenda/corrigenda, on the websites referred at Clause 1.1 of the RFP.
  - xvii. The Bid and all related correspondence and documents in relation to the Bidding Process shall be in English language. Supporting documents and printed literature furnished by the bidder may be in any other language provided that they are accompanied by translations of all the pertinent passages in the English language, duly authenticated and certified by the bidder. Supporting materials, which are not translated into English, may not be considered.
-

For the purpose of interpretation and evaluation of the Bid, the English language translation shall prevail.

- xviii. The JMRC reserves the right to verify all statements, information and documents submitted by the bidder in response to the Bid Document. Any such verification or lack of such verification by the JMRC shall not relieve the bidder of its obligations or liabilities hereunder nor will it affect any rights of the JMRC there under including as provided under clause 3.1(x) of this RFP.

### **3.2 DUE DILIGENCE BY BIDDER**

- i. The bidders are required to examine carefully all the contents of the RFP Document, SHE manual & GCC of the station including instructions, conditions, forms, terms, specifications and take them fully into account before submitting the Bid. Failure to comply with the requirement(s) of RFP Document will be at the bidder's own risk & responsibility.
- ii. Bidders are advised to carry out extensive survey of earmarked pillars and analyse at their own cost, before submitting the Bid. The bidders must familiarize themselves with the spaces available for installation and operation of Micro Cell prescribed in this RFP of JMRC, visit the pillars & take note of the extra precautions to be taken in operations.
- iii. Bidders are required to verify the information given in respect of area, locations etc. and seek clarifications, if any, from JMRC before submitting the bid.
- iv. All the information related to JMRC is under public domain, the bidder can still raise queries, if there are any, while the bidding process is on. Once the process is over, no claims or queries shall be entertained.

### **3.3 SITE VISIT AND PRE-BID CONFERENCE**

- i. For the purpose of affording bidders an opportunity to obtain clarifications and /or give suggestions with regard to this RFP and bid process, a pre-bid conference has been arranged as per the schedule indicated in the Clause 1.2.
- ii. Bidders are advised to visit the sites (the designated Metro Pillars) to get specific idea about respective Micro Cell Space(s) before attending the pre-bid conference.
- iii. Queries / request for clarification should be submitted through e-mail or in writing by the date & time prescribed in Notice Inviting Bids and the same received after the date & time prescribed may not be taken into consideration.
- iv. The post conference queries regarding this RFP, may be addressed to :

*Joint General Manager (Revenue), JMRC,  
2<sup>nd</sup> Floor, RSIC Wing, Udyog Bhawan,  
Tilak Marg, C-Scheme, Jaipur - 302005.  
Tel. No.0141- 5192407, Email: [jgmrev@jaipurmetrorail.in](mailto:jgmrev@jaipurmetrorail.in)*

### 3.4 CLARIFICATION / AMENDMENT / ADDENDUM

- i. At any time prior to the deadline for submission of Bid, JMRC may, for any reason, whether at its own initiative or in response to clarifications requested by a bidder, modify the Bidding Document by the issuance of addenda/corrigenda.
- ii. Any addendum/corrigendum/amendment or responses to the queries, thus issued will be sent in writing through the official website of JMRC <https://www.jaipurmetrorail.in>, <https://transport.rajasthan.gov.in/jmrc> State Public Procurement Portal [www.sppp.rajasthan.gov.in](http://www.sppp.rajasthan.gov.in) and state e-procurement portal <https://eproc.rajasthan.gov.in>. Prospective bidders are advised to keep visiting these websites regularly for updates.
- iii. In order to offer the bidders reasonable time for taking an addendum/corrigendum into account, or for any other reason, JMRC may, in its sole discretion, extend the Last date and time of Bid submission.
- iv. JMRC may or may not reply to queries at its discretion.
- v. JMRC may issue clarification/ amendments on its own or in response to queries. All clarifications and interpretations issued by the JMRC shall be deemed to be part of the Bid Document. Verbal clarifications and information given by JMRC or its employees or representatives shall not in any way or manner be binding on the JMRC.
- vi. Requests for clarifications shall be furnished in the following format:

S. No.	RFP Clause/ Annexure Reference No.	Subject/Title	Query / Clarification sought

### 3.5 DETAILS OF MICRO CELL SPACE(S), ESTIMATED LICENSE FEES AND BID SECURITY (EMD)

Details of the Micro Cell Space(s) to be licensed out alongwith amount of Bid Security are as given in the Table below:

S. No.	Micro Cell Code	Metro Pillar Number	Location	Estimated License Fees per month (Rs.)	Bid Security Amount (Rs.)
[A]	[B]	[C]	[D]	[F]	[G]
1.	MC101	101	Between Civil Lines Metro Station to Railway Station Metro Station	3,000	4,000
2.	MC102	102		3,000	4,000
3.	MC112	112		3,000	4,000
4.	MC113	113		3,000	4,000

**Note:**

- i. A Bidder can bid for all or any number of Micro Cell space(s) listed above.
- ii. Maximum 8 mounts shall be allowed in a Micro Cell on each pillar.
- iii. Though the RFP document is common for all the 4 Metro pillars (Micro Cell spaces), the bid for each Micro Cell space shall be separately evaluated and EMD / Bid security is to be submitted for all the Micro Cell Space(s) for which bid is being submitted.

### 3.6 COST OF BID DOCUMENT (TENDER FEE) AND E-TENDER PROCESSING FEE

- i. Complete bid document can be downloaded for online submission from the website <https://eproc.rajasthan.gov.in>. Cost of Bid Document (Tender fee) Rs. 5,00 (Rs. Five Hundred only), inclusive of GST shall be paid in the form of Demand Draft/ Bankers Cheque of Scheduled Bank drawn in favour of 'Jaipur Metro Rail Corporation Ltd.', payable at Jaipur. The Tender fee is non-refundable.
- ii. In addition, e-tender processing fee Rs. 1,000 (Rs. One Thousand only) shall be paid in the form of Demand Draft/ Bankers Cheque of Scheduled Bank drawn in favour of 'Managing Director, RISL', payable at Jaipur.
- iii. Any Bid not accompanied by proof of payment of cost of bid document (Tender fee) / e-tender processing fees in acceptable form will liable to be treated as being non-responsive and shall be rejected.

### 3.7 BID SECURITY / EARNEST MONEY DEPOSIT (EMD)

- i. EMD (Bid Security) of Rs. 4,000 (Rupees Four Thousand Only) for each Micro Cell and Rs. 16,000 (Rupees Twelve Thousand only) for all four Micro Cells is to be deposited in the form of Demand Draft/ Bankers Cheque on any Scheduled Bank drawn **in favour of Jaipur Metro Rail Corporation Ltd., payable at Jaipur**, shall form part of the bid. The EMD can also be deposited in the form of Bank Guarantee (**valid up to 180 days from the Last date of Bid submission**) in the format enclosed at Annexure-VIII drawn on any Scheduled Bank (having its branch in Jaipur) in favour of Jaipur Metro Rail Corporation Ltd., payable at Jaipur.
- ii. The Bid Security / EMD shall be submitted in JMRC office as prescribed in Clause 3.8 (iii).
- iii. Any Bid not accompanied by valid Bid Security / Earnest Money in acceptable form will be liable to be treated as being non-responsive & shall be summarily rejected.
- iv. The Bid Security / Earnest Money Deposit shall be forfeited in the following cases:
  - a. when the bidder withdraws or modifies its bid after opening of bids;
  - b. when the bidder does not execute the agreement, if any, after signing of Letter of Acceptance within the specified period;
  - c. when the bidder does not deposit the performance security within specified period after the issuance of LoA; and
  - d. If the bidder breaches any provision of code of integrity prescribed for bidders specified in the RTPP Act and Chapter VI of the RTPP Rules.

The decision of JMRC in this respect shall be final and binding.

- v. The Bid Security / Earnest Money of successful bidder may be adjusted against Performance Security Deposit or shall be refunded after deposition of the full Performance Security Deposit, as the case may be.
- vi. The Bid Security / Earnest Money shall be returned promptly after the earliest of the following events, namely:

- a. the expiry of validity of bid security;
  - b. the execution of License agreement and full performance security is furnished by the successful bidder;
  - c. the cancellation of the procurement process; or
  - d. The withdrawal of bid prior to the deadline for presenting bids, unless the bidding documents stipulate that no such withdrawal is permitted.
- vii. If the successful bidder fails to deposit the required security deposit(s) or to execute the agreement within the specified period without any valid reasons, such failure will be treated as a breach of the terms and conditions of the tender and will result in forfeiture of the Earnest Money, in part or in full, at the discretion of Jaipur Metro Rail Corporation Limited (JMRC).
- viii. The EMD of unsuccessful bidders will be refunded/returned within 30 days after signing of the License Agreement with the successful bidder or after the expiry of the validity of the offer (unless extended), whichever is earlier. No interest shall be paid on the EMD.

### 3.8 SUBMISSION OF BID

- i. Submission of bids through online process is mandatory for this Tender. Bids sent by post, fax or e-mail or presented in person will not be considered.
- ii. The bidder should get itself registered on procurement portal, <https://eproc.rajasthan.gov.in>, and create users and assign roles on this portal. Further to this, bidder shall download Notice Inviting Bids (NIB) and the RFP from this site. The complete bid document can also be seen on JMRC website <http://www.jaipurmetrorail.in>, <https://transport.rajasthan.gov.in/jmrc> and State Procurement Portal [www.sppp.rajasthan.gov.in](http://www.sppp.rajasthan.gov.in).

To participate in online bidding process, bidders must procure a Digital Signature Certificate (class 2 / class 3 category) as per Information Technology Act-2000 using which they can digitally sign their electronic bids. Bidders can procure the same from any licensed Certifying Authority for e-tender portal. Bidders who already have a valid Digital Signature Certificate (DSC) need not procure a new DSC. This DSC will be used to sign the bids submitted online by the bidder. Unsigned bids shall not be entertained and be summarily rejected.

- iii. Bidder (authorised signatory) shall submit their offer on-line in Electronic formats both for technical and financial bid. The technical bid should also contain scanned copy of DD / Bankers Cheque for Tender Fee & e-tender Processing Fee and scanned copy of DD/ Bankers Cheque /Bank Guarantee for EMD. In addition to this, DD/ Bankers Cheque /BG for Tender Fee, e-tender Processing Fee and EMD must be submitted physically at the following address of JMRC **with a covering letter mentioning therein the details & name of the RFP**, by the scheduled date and time as per NIB Clause 1.2(xv):

*Joint General Manager (Revenue)  
Jaipur Metro Rail Corporation Limited,  
2<sup>nd</sup> Floor, RSIC Wing, Udyog Bhawan ,  
Tilak Marg, C-Scheme, Jaipur-302005*



In the absence of physical submission of the DD/ Bankers Cheque / BG for Tender Fee, e-tender Processing Fee and EMD in JMRC, the Bid shall summarily be rejected.

- iv. JMRC will not be responsible for delay in online submission due to any reason. For this, bidders are requested to upload the complete bid well advance in time so as to avoid last minute issues like slow speed; choking of web site due to heavy load or any other unforeseen problems.
- v. Utmost care must be taken to name the files /documents to be uploaded on portal. There should not be any special character or space in the name of file, only underscores are permissible. Uploaded files that are unable to download, or corrupted, or password protected, or virus/malware infected, or the likes shall not be accepted and the bid shall be liable to be rejected.
- vi. A single-stage two bid selection procedure shall be adopted. The Bid shall contain:

**a) Part-A: Technical Bid**

This Part should contain the Technical Bid consisting of a PDF copy of this 'Request for Proposal' with each page digitally signed by the bidder in acceptance of the terms and conditions therein, along with scanned copy of all the required documents, DD/BC/BG with Annexures of RFP duly filled in support of eligibility, EMD, tender fee and e-tender processing fee. **Apart from being digitally signed, all the documents should be physically signed and stamped on each page, before scanning, by the authorised representative of the bidder.**

All the applicable Annexure shall be duly filled, physically signed & scanned (in PDF format) and digitally signed on each page and to be submitted online as part of technical bid.

**Financial proposal should not be indicated at any place in the Technical Bid, otherwise the Proposal shall be summarily rejected.**

**b) Part-B: Financial Bid (BOQ)**

This Part should contain the Financial Bid in the prescribed Format as per Annexure-VII.

Utmost care should be taken to upload the Financial Bid. Any change in the format of Financial Bid file shall render it unfit for bidding. Following Steps may be followed in submission of Financial Bid:

- i. Download format of Financial Bid in XLS/ XLSX format.
- ii. The same XLS/ XLSX file is a password protected file. Don't unprotect the file.
- iii. Fill '**Bidder's Name**' & quote **percentage above or below** in Green back-ground cells in the downloaded Financial Bid format. Don't fill-in other colour cells.
- iv. Validate the above sheet and save the same file in your computer and upload this duly filled file.

Note: Rate quoted should be all inclusive for carrying out activities as detailed in the scope of License. It is to be noted that GST and any other taxes,



### 3.9 EVALUATION OF BIDS

- i. The bids will be opened online on website at the date and time, place as specified in the Clause 1.2 (Notice Inviting Bids) of this RFP in the presence of bidders or their authorized representatives who choose to attend the opening of Bid. The bidders or their authorized representatives who are present to witness the Bid opening shall sign an attendance sheet / register evidencing their attendance as a witness to the Bids opening process. In the event of the specified date of Bid opening being declared a holiday, the Bids will be opened on the next working day at the same time and place or on any other day/time, as intimated by the JMRC.
- ii. Only Technical Bids will be opened first and evaluated Micro Cell-wise as per the eligibility criteria set forth in this RFP document.
- iii. Financial Bids will remain unopened until the time of opening of the Financial Bids.
- iv. The Financial Bids of only those bidders who clear Technical evaluation stage will be opened & evaluated. The date and time of opening of Financial Bids shall be communicated to technically qualified bidders through state e-procurement website <https://eproc.rajasthan.gov.in>. The technically qualified bidders may attend the opening of the Financial Bid, if they so desire.
- v. The bidders or their authorized representatives who want to be present to witness the Financial Bid opening shall sign on attendance sheet / register evidencing their attendance as a witness to the Financial Bid opening process. In the event of the specified date of Financial Bid opening being declared a holiday, the Financial Bids will be opened on the next working day at the same time and place or on any other day/time, as intimated by the JMRC.
- vi. The **Micro Cell-wise financial evaluation shall be done as per percentage above or below quoted by bidder in Column No. 6** of Financial Bid / BOQ. Out of these, the bidder whose quote in percentage is highest will be finally selected and adjudged as the successful bidder for that Micro Cell.
- vii. In case two or more responsive bidders have quoted the same rate of License Fee, which is also the highest License Fee offered, then all such bidders will be given an opportunity to revise their financial bid by submitting fresh financial bid(s), which shall necessarily be higher than the previous bid. The revised financial bid shall be submitted by the date and time as notified to the concerned bidders.
- viii. In case two or more responsive bidders again quote the same rate of License Fee in their revised Financial Bids, then JMRC will resort to an open auction among the same bidders (i.e., who have quoted the same License Fee) and the bidder for respective bid whose offer is highest, shall be declared as successful bidder. The date and time of auction will be notified to the concerned bidders.
- ix. For the proper evaluation of the proposal, if clarifications are found to be necessary JMRC may at its discretion, ask for such clarification and bidder shall be obliged to provide such clarifications within the time specified by JMRC.

- x. Notwithstanding anything contained in the RFP Document, the Authority reserves the right to (i) accept any Bid not necessarily highest, (ii) reject any Bid, (iii) reject all Bids and annul the bidding process, without assigning any reason at any point of time before issuance of a Letter of Acceptance, without incurring any liability.
- xi. All decisions whether a bid is non- responsive, unacceptable or whether a Bid Security is fraudulent or unacceptable or non- compliant, will be that of JMRC.
- xii. No further discussion/ interface will be held with the bidders whose bids are rejected/ disqualified / technically disqualified.

### **3.10 AWARD OF CONTRACT, SIGNING OF LICENSE AGREEMENT/ EXTENDED LICENSE AGREEMENT & SECURITY DEPOSIT**

- i. Prior to the expiry of the period of validity of the Bid, the successful bidder shall be notified through a Letter of Acceptance (LoA) sent through email to be confirmed in writing by Registered / Speed Post / By hand that its Bid has been accepted.
- ii. Upon receipt of the 'LoA', the successful bidder(s) shall return one copy of the LoA duly accepted, signed and stamped by its authorized signatory **within 10 working days** of from the date of issue of LoA and submit security deposits **within 20 days** from the date of issue of LoA, as below:
  - a. **Performance Security Deposit** equal to 6 months monthly license fee (of first year) for each Micro Cell in the form of Bank Guarantee (Annexure-IX) from any scheduled bank (having its branch at Jaipur) in favour of Jaipur Metro Rail Corporation Ltd. The Bank Guarantee should remain valid for a period of 9 months (Nine months) beyond the date of expiry of the 'License Agreement' from the date of issue of PBG. The Performance Security is to ensure due performance of all obligations of the Licensee under the Contract against an event of default by the Licensee and/or any material breach of its obligations there under. The Performance Security Deposit shall be refunded after adjustment of outstanding dues, if any, made in accordance with this contract, to the bidder on his application within one month after the site is handed over to JMRC at the end of full term of License period.
  - b. **Installation Security** of Rs. 10,000 per Micro Cell space (per Micro Cell) in the form of bank guarantee (Annexure-X) from any scheduled bank in favour of Jaipur Metro Rail Corporation Ltd., which shall be returned without any interest, after completion of initial installation work or after 6 months from the date of issue of NTP, whichever is later, after adjusting the cost of damages to JMRC properties, if any, after receipt of certificate of commencement from the agency. The installation security is to ensure that there is no damage to the JMRC assets during installations by the Agency. **The Installation Security Deposit shall be kept valid for a period of 9 months (Nine months) from the date of Issue of Bank Guarantee.** In case of delay in installation, agency will have to extend the validity of Installation Security for a period as per JMRC.
- iii. The Performance Security Deposit and Installation Security can also be deposited in the form of DD/ Banker's Cheque of scheduled bank drawn in the favour of Jaipur Metro Rail

Corporation, payable at Jaipur.

- iv. The Security Deposits shall not carry any interest during the tenure of the License.
- v. Subsequent to acceptance of 'LOA' by the successful bidder as above, and deposition of Performance Security Deposit & Installation Security Deposit, a demand for deposit of first quarter License Fee shall be raised by JMRC. The Licensee shall make the payment upfront.
- vi. Pillar-wise License Agreement/ License Fee agreement on a non-judicial stamp paper of appropriate value as per Stamp Act, as per format at Annexure -V shall be executed between the successful bidder and JMRC within 30 days of issue of LoA. The original Agreement shall be retained by JMRC and the copy shall remain with Licensee.
- vii. The selected bidder shall not be entitled to seek any deviation, modification or amendment in the License Agreement.
- viii. Till the signing of the License Agreement, the LoA shall form a binding contractual agreement between JMRC and the successful bidder(s) as per terms of this RFP.
- ix. The cost of Stamp Duty for execution/ registration of License Agreement and any other related Legal Documentation charges / incidental charges shall be borne by the successful bidder only.
- x. JMRC shall retain the right to withdraw the LoA in the event of the successful bidder's failure to accept the LoA within the limit specified in the above clause. In that event, JMRC shall forfeit the Bid Security of the successful bidder. The bidder shall not seek any claim, compensation, damages or any other consideration whatsoever on this account.
- xi. If the bidder fails to deposit the required Security Deposits or to execute the agreement within the specified period without any intimation to JMRC, such failure will be treated as a breach of the terms and conditions of the tender and may result in forfeiture of the Earnest Money Deposit (Bid Security) / Security Deposits, in part, or in full at the discretion of JMRC.
- xii. JMRC shall have the right to invoke and appropriate the proceeds of the Security Deposits in whole or in part, without notice to the Licensee in the event of breach of this Agreement or for recovery of liquidated damages or penalties.
- xiii. The Performance Security Deposit shall be refunded after adjustment of outstanding dues, if any, made in accordance with this contract, to the bidder on his application within one month after at the end of full term of License period.
- xiv. JMRC shall reserve the right for deduction of JMRC dues from the Performance Security Deposit at any stage of agreement, i.e., currency / completion / termination / surrender, against:
  - a. Any amount imposed as penalty and adjustment for all losses/damages suffered by JMRC for any non-conformity with the terms & condition of the agreement.
  - b. Any amount for which JMRC becomes liable to the Government/Third party due to any default by any employee / agent of the Licensee.



- c. Any payment/ fine imposed under the order/judgment of any court/consumer forum or law enforcing Licensee or any person working on behalf of the Licensee.
- d. Any other outstanding JMRC's dues/ claims, which remain outstanding after completing the course of action as per this License Agreement.
- a. In case of non-acceptance of LoA or non deposition of security deposit(s) or non signing of License Fee by the successful bidder, even after 30 days of issue of LoA, JMRC shall cancel the LoA and may award the contract to the bidder next in the ranking, at its discretion.

#### **4. SPECIAL CONDITIONS OF CONTRACT (SCC)**

##### **4.1 SCOPE OF LICENSE & TECHNICAL REQUIREMENTS**

- i. JMRC shall provide 1.5 meter height space on the Metro pillar(s) just below top collar for clamping of telecommunication equipment. The clamp equipment should not project beyond 2 feet of pillar surface. Road traffic conditions and regulations of civic /statutory authorities in regards to installation must be taken care by licensee.
- ii. JMRC shall provide / permit following against this Contract:
  - a) Permissions to install equipment at the top (just below collar) of designated metro pillar(s).
  - b) Permission (right of the way) to lay Optical fibre / Copper cable (power) for operator's connectivity around station are & along via-duct upto the Micro Cell space(s) to connect equipment, subject to technical feasibility.
  - c) Permission to share the Telecom equipment & licensed space with Telecom Operators.
  - d) Permission to obtain electricity directly from electric supply company & provide suitable space for installation of meter, etc., in case licensee obtain power connection directly from JVVNL.
  - e) Permission to lay electrical cable from nearest electricity point of Jaipur Metro (in case power supply is taken from JMRC) on chargeable basis as mentioned in this RFP).
  - f) Permission to arrange earthing near the metro pillar as per technical suitability.
  - g) Space for back haul connectivity ( M/W or OFC) at nearest station, if available.

The charges of additional services/ permissions including above, whenever specified in this RFP, shall be charged accordingly. Else, the permissions as above and other associated services, shall be part of license fees.

- iii. In metro operations, safety & security are to be given top priority. The design of the mounting structure and fastening procedure should have due approval of any reputed institutions like IITs/ NITs to ensure their safe and secure fixing on pier/ pier cap. All installation activities are to be done with extra precautions and under the supervision of its responsible executive and advance intimation to JMRC's nodal officer for coordinating between various departments.
- iv. Optical fiber from the nearest RTT to the BTS/ Transmitting equipments on pier/ pier cap should be laid with proper fastened brackets on building structure and on station segments. There are holes available on the segments forming viaduct.
- v. The Micro Cell space(s) will be handed over by JMRC on "as is where is" basis. The Licensee shall install its own fixtures and equipment at the said space after duly obtaining all necessary approvals from JMRC, permissions and licenses from Statutory/ Authorities at its own cost and expense.

- vi. The Micro Cells should be installed within the dimensions demarcated by JMRC at site, for the purpose. The installation activities and material shifting is to be arranged by the successful bidder through temporary arrangement of crane / ladder etc.

#### **4.2 PRELIMINARY PLANNING & NOTICE TO PROCEED (NTP)**

- i. Soon after issue of LoA, the Licensee shall submit Preliminary Plans, Specifications, design data and preliminary schedule as hereinafter defined, to JMRC for each of the Micro Cell space for which it has been adjudged as successful bidder within 45 days of from the issuance of LoA .
- ii. As used herein, Preliminary plans and specifications shall mean schematic development documents, as applicable and may consist of:
  - a) Drawing and technical specifications of the equipment
  - b) Installation details of the equipment / fixtures
  - c) Fixing arrangements of equipments & infra on pillars
  - d) Electrical wiring plan and telecommunication and data wiring
  - e) Connectivity plan (Microwave/OFC)
  - f) Power connection plan
  - g) Earthing connection plan
- iii. The design of mounting structure and fastening procedure should have approval of any reputed institute like IITs / NITs, etc.
- iv. JMRC will have right to consult 3<sup>rd</sup> party experts to get the spectrum and designs checked to ensure safety of installation.
- v. JMRC will have the right to approve the Licensee's preliminary plans and specifications with such changes, as it may find necessary and compliance of all such changes and modifications in the preliminary plans as suggested by JMRC shall be mandatory. The Licensee shall submit Final Plans, Specifications and schedule to JMRC within 10 days from JMRC's communication requiring modifications.
- vi. JMRC shall communicate its approval by way of NTP (Notice To Proceed) authorising the Licensee to initiate the installation activity as per specifications / plans.
- vii. The preliminary plans can also be submitted Micro Cell space(s)-wise and accordingly NTP shall be issued for that Micro Cell space(s) as per requirements.
- viii. Even after issue of NTP, the work at site can be started after clearance of all statutory obligations / requirements.

#### **4.3 ELECTRICITY PROVISIONING**

- i. JMRC can provide light and power connection upto 5KW with sub-metering arrangements, if technically feasible. In such case, electrical cable form nearest distribution point of JMRC to the site shall be laid by the Licensee and the installation charges for provision of permanent electrical connection shall be as per Annexure XI.

- ii. Alternatively, Licensee shall be allowed to take power connection from Discom / JVVNL directly.
- iii. In both the situation as per sub clause (i) & (ii) above, considering the stipulated provisions on electric safety at Metro spaces, the Licensee shall adhere to Rules and Guidelines for relicensing, upkeep and maintenance of electric power as per Annexure-XI, even if the electricity connection is taken directly from the Discom / JVVNL.
- iv. The Licensee voluntarily and unequivocally agrees not to seek any claim, damages, compensation or any other consideration whatsoever on account of time and costs associated in provision of electricity.
- v. No DG sets shall be allowed to be kept at the metro pillars for operating of these Micro Cells permanently.
- vi. Licensee will arrange separate earthing and JMRC shall facilitate by arranging space near the metro pillar at ground level for earthing.

#### **4.4 HANDING OVER POSSESSION TO JMRC**

- i. That the said space which has been handed over to the Licensee under this contract will be kept in good Condition and maintained properly by the Licensee at their own cost. If the space is not handed over in good condition as required under this contract, JMRC reserves the right to seek exemplary damages and identification.
- ii. No Tenancy/sub-Tenancy is being created by JMRC in favour of Licensee under or in pursuance of the License agreement as a result of this RFP and it is distinctly and clearly understood, agreed and declared by and between the parties hereto that:
  - a. That the Licensee shall not have or claim any interest on the said spaces as a tenant / sub-tenant or otherwise:
  - b. That no right as a tenant/ Sub-Tenant or otherwise is purported is intended to be created or transferred by JMRC in favour of Licensee in or in respect of the said spaces, except to carry out their activities over the granted space under this License agreement and
  - c. That the rights, which Licensee shall have in relation to the said spaces, are only those set out in this agreement.
- iii. Licensee shall deliver to JMRC, physical possession of the vacant licensed spaces at the end of the term of the Agreement or on termination of contract, in good condition removing all the fixtures, cables equipments etc.
- iv. That if the Licensee fails to vacate the space within a grace period of 15 days of consumption or termination of the contract, the Licensee shall be deemed to be an unauthorized occupant on the said spaces and shall be liable to pay a fee @ Rs.1000 per day for any period of occupation beyond that date along, which will be charged over and above the license fees due.
- v. The installation site is required to be cleared off all the construction material and debris before leaving the site and making it operational. Repair to damages like concreting, plaster



and paint work to JMRC assets shall be done by the Licensee after completion of work, at its own cost.

#### 4.5 OTHER TERMS & CONDITIONS

- i. The SHE Manual (Safety, Health & Environment manual) of JMRC as available on JMRC website <http://transport.rajasthan.gov.in/jmrc>, are part to this RFP Process and are applicable as a whole on this RFP process & the pursuant contract agreement. However, wherever the provisions contained in this RFP document are in conflict with the SHE Manual, the provisions contained in the RFP document shall prevail. Bidders are advised to carefully read the SHE Manual uploaded on the Corporation website.
- ii. The Licensee shall nominate a Manager / Supervisor whose scope of services shall be to supervise the operations in the said spaces/ equipments.
- iii. To ensure that safety measures are taken care of during installation
- iv. The Licensee will ensure safety and security of the mobile equipments / fixtures and other related equipments installed in the allotted area. JMRC in any case will not take any responsibility. However, in the event of any theft/loss of any nature, the Licensee will indemnify and keep indemnified JMRC for any losses on this account.
- v. The Licensee shall use the Micro Cell space(s) allotted only for the purpose indicated in this Agreement and for no other purpose whatsoever. Any Change in usage may be permitted only on approval of the competent authority of the Licensor.
- vi. The Licensee is not allowed to use the Micro Cell space site for advertisement / marketing.
- vii. The Licensee can only share / sub-license the Micro Cell and Micro Cell space(s) to end user Telecom operators / service providers and not to any other Infra providers.
- viii. This license contract does not entitle Licensee or its representatives or sub Licensee to have any free access to the paid / concourse / platform area or to the paid parking area.
- ix. In exceptional circumstances, JMRC reserves the right to change the location allotted for installation of equipment, infrastructure of Micro Cell at any time and may at its discretion call upon the Licensee to shift the installed infrastructure to an alternative space. In such a case, the Licensee shall be bound to shift the infrastructure immediately and accept the said alternate location identified in the spaces. Reasonable recompense of the cost of such shifting shall be reimbursed by JMRC to the Licensee by adjustment against payment due to JMRC against License fees. An assessment of such reasonable cost of shifting would have to be submitted by the Licensee to JMRC for approval within one week of the notice to shift. The decision of JMRC with regard to the amount of reimbursement shall be final.
- x. Only Licensee paying the accepted license fees, associated charges and electricity bill regularly and adhering to its obligations under the terms and conditions of this RFP and the consequential license agreement(s) shall utilise the licensed space during the license period.
- xi. If the Licensee does not install the equipments / Infra or wishes to close down the service during the license period, it can do so after an initial lock in period of 2 years and by giving



- 3 months** notice to JMRC. In case, the Licensee vacates or wants to vacate the licensed space before the initial lock in period of 2 years, its security deposit(s) and advance license fees pending with JMRC, if any, shall be forfeited. The Micro Cell space(s) of such telecom equipment / infrastructure etc. should be cleared and restored to the original condition to the satisfaction of the licensor, who shall be free to utilise / license out the relicensed space for any purpose, including for installation of the Telecom equipment of another operator / Infrastructure provider, at its sole discretion.
- xii. JMRC shall not be responsible in any way for loss or damage by any means caused to the Licensee's infrastructure/ telecom equipments.
  - xiii. On expiry of the license period or on termination of the license by JMRC on account of any breach on the part of the Licensee for any other reason, the Licensee shall deliver the possession of the licensed Space in good condition after removal of their goods and other equipments from the license Space immediately, failing which JMRC reserves its right to remove all such equipments at the cost and risk of the Licensee and demand payment for such removal. If such payment is not made within 10 days, JMRC shall be at liberty to dispose of the goods/equipments/materials of the Licensee by public auction to recover the cost. The Licensee shall not be entitled to raise any objection in such an eventuality.
  - xiv. The license herewith granted shall not be construed in any way as giving or creating any other right or interest in the said Micro Cell Space to or in favour of the Licensee but shall be construed to be only as a license in terms & conditions herein contained.
  - xv. The Licensee shall keep in mind applicable rules and regulations and instructions issued from time to time while occupying the licensed Space. JMRC will be free to take action against the Licensee for violating the same.
  - xvi. The Licensee shall ensure that proper care is taken under skilled supervision during installation / maintenance of telecom infrastructure and associated equipments so that no damage is caused to JMRC assets or spaces.
  - xvii. The Licensee shall ensure that personnel (including outsourced Licensee staff, if any) deployed in connection with installation, operation and maintenance of infrastructure equipments for Micro Cell behave decently and courteously at the site and indulge in no act that may adversely affect the reputation of the Corporation.
  - xviii. In case of any damage to JMRC property during installation, for actual costs whatsoever for restoration to its original position will be recovered from Installation Security deposit & Performance Security deposit of the Licensee and same will not be challenged in whatever manner.
  - xix. Any damage to JMRC assets during erection and operation of Micro Cells shall be the responsibility of Licensee and shall be rectified by the Licensee at its own cost on top priority with intimation to Jaipur Metro. Failure to comply the same in reasonable time may attract penalty to Licensee @ 2 times of the maintenance cost or more as assessed by JMRC as per site condition.
  - xx. If the activities by Licensee during installation and maintenance of equipments may harms or cause accident to public, it will be the sole liability of the Licensee. For the same, the

Licensee shall submit an indemnity certificate to the JMRC before start of the work in addition to Installation Security deposit.

- xxi. The Licensee shall use the space only for the purpose for which it has been licensed. JMRC reserves the right to penalize the Licensee upto Rs.5,000 for every occasion, where there has been any misuse of the Licensee.
- xxii. The Licensee shall be allowed to use the licensed space(s) on pillars for more than one mobile / telecom operators, with maximum 8 mounts as per terms & conditions of this RFP.
- xxiii. That the overall control and ownership of the space shall remain vested with JMRC who will have the right to inspect the whole or part of the licensed space as and when considered necessary, with respect to its bonafide use and in connection with fulfilment of the other terms and conditions of the license agreement. If any fixture or utility relating to operation of metro rail is running through the area licensed, proper precautions as advised by JMRC will be taken by Licensee. The loss due to obstruction so caused on the business of the Licensee will not be borne by JMRC.
- xxiv. JMRC Employees and/or personnel authorised by it / Fire Officer / authorized personnel will have unfettered access to the spaces, for inspection / checking of fire detection and suppression measures etc. The instructions issued by the JMRC's fire officer shall be obeyed fully without any demur. Any costs associated with carving out the instructions of the authorised personnel of JMRC will be borne solely by the Licensee.
- xxv. Periodical monitoring on regular basis is to be done for the safety and technical evaluations for the stability of Mounting & fixtures by Licensee.
- xxvi. A joint inspection of JMRC maintenance staff (not below the rank of manager) with Micro Cells maintenance in-charge shall be conducted once in a year to ensure safety of Micro Cell structures.
- xxvii. The Licensee will strictly not encroach up common areas / circulating areas or any other space, and restrict his operation to within the licensed area, in case, the Licensee encroaches upon the common area, circulating area or any other space then a line/ compensation @ Rs.1000 on the first occasion, Rs. 2000 on the second occasion and Rs. 3000 on the third occasion will be imposed by JMRC. Thereafter, JMRC reserves the right to revoke the license and forfeit the interest free security deposit.
- xxviii. The Licensee is not allowed to use the site for sale of products or services. The licensed space cannot be used for advertisement or branding by the Licensee. The Licensee shall be allowed to place only the signage's as required to meet statutory obligations.
- xxix. Licensee shall ensure a high standard of hygiene and cleanliness so as to create a very clean and healthy environment. Any physical damage or injury to the commuters or passers-byes due to lapses on the part of Licensee, it will be the sole responsibility of the Licensee only and JMRC will have no legal obligations or liability towards the injured.
- xxx. Licensee shall ensure that fire detection and suppression measures if installed by it inside Equipment Room spaces (if fabricated) or outside are kept in good working condition.

- xxxi. Licensee shall bear the cost of minor day-to-day repairs and maintenance at the Micro Cell space(s), whenever, required.
- xxxii. The Licensee to take prior written approval from JMRC through a written notice prior to commencement of any alteration works and if necessary JMRC reserves the right to ask for and review the worth drawings before providing consent.
- xxxiii. The Licensee will be responsible for the costs of removing debris from the area around metro pillars and will be responsible for all damage to the common areas below via-duct, during the process of installation. Any special cleaning or clearance necessary, as a result of the installation and any other costs incurred by JMRC including any extra security costs, which are caused by, or in connection with the works, will also be to the Licensee's account.
- xxxiv. Licensee should ensure that all electrical wiring, power outlets and gadgets are used and maintained properly, for guarding against short circuits/fires. The Licensee should also ensure that all notified statutory provisions and standards are observed in this regard.
- xxxv. Licensee should ensure that equipment installed do not interfere with the sensitive electronic equipment installed along with Jaipur Metro Corridor including TETRA based train radio network / system and the Licensee should submit a third party certificate to this effect within four (4) weeks after installation of its radiating equipments (operator wise). If any interference is noticed, than the Licensee will undertake all necessary steps at his own risk and cost to remove such interference. Failure to do so within a period of two working days, authorizes JMRC to take all necessary steps to prevent this interference including shutting down of concerned Micro Cell equipment at the risk and cost of the Licensee. In addition a penalty, of Rs.10,000 (Rupees Ten Thousand Only) for each occasion of interference may be imposed by JMRC. Test reports and any other supportive documentation as may be required/requested by JMRC, will have to be supplied immediately. Third party certification from a reputed Licensee has to be provided by the Licensee, as and when required.
- xxxvi. The HDPE pipe & cables (OF Cables, LCX Cables, RF Cables and electrical cables etc.) to be used in installation of equipments shall be manufactured from fire retardant, low smoke, zero Halogen material and shall meet all the requirements specified by relevant international standards and confirming to infrastructure / installation practices as required in Metro rail network. The Licensee shall submit to JMRC, factory, acceptance tests report or type test reports along with certificate from the manufacture duly endorsed by Licensee of HDPE Pipe and Cables (OF Cables, LCX Cables and RF Cables etc.) as & when required. The Licensee shall fully responsible for any deficiency noticed and will take necessary steps at its own risk and cost to replace such HDPE pipe & Cable (OF Cables, LCX Cables and RF Cables etc.).
- xxxvii. The Micro Cell structure and fixing arrangement should be designed to cater to a wind pressure of 180 KMs /per hour and such design should have approval of any authorised / competent Agency of structural design.

#### **4.6 DURATION OF CONTRACT / LICENSE AGREEMENT**

- i. The period of the license agreement(s) as prescribed in this RFP will be initially for 5 years from the date of **46<sup>th</sup> day of issue of NTP** in respect of each Micro Cell space. It can be extended further, on the behest of the Licensee upto two years period (total 7 years) on mutual agreement on same terms and conditions. The tenure of the License agreement shall commence from the date of commencement of License Fee (i.e. 46<sup>th</sup> day of issue of NTP).
- ii. Till the signing of the license agreement, the LoA shall form a binding contractual agreement between JMRC and the successful Bidder as per terms of this RFP.
- iii. A separate application for willingness of extension of license period in respect of each Micro Cell space would require to be submitted by the Licensee to JMRC, 3 months in advance of the expiry of the original license period of 5 years. A 'Letter of Extension' shall be issued by JMRC to the Licensee(s) with regard to the particular Micro Cell Space(s). The Licensee shall have to submit the Security Deposit for the extended period as prescribed in Clause 3.10 of this RFP and execute a license agreement for the extended period as prescribed in Clause 3.10 of this RFP.
- iv. That the Agreement provided herein shall terminate at the end of the period agreed to herein i.e., five (5) / (7) years from the date of start of License Fee, except that the agreement may also be terminated earlier in accordance with the terms of this contract.

#### **4.7 STATUTORY OBLIGATIONS**

- i. The Licensee shall comply with all applicable statutes, ordinances, rules and regulations of central, state governments, municipal bodies and all applicable rules and also regulations of the Rajasthan Fire department. The Licensee shall also comply with all rules and regulations under the Metro Railways (Construction of Works) Act, 1978 and Metro Railways (Operation and Maintenance) Act, 2002 and also to instructions issued from time to time from the office of Director (Corporate Affairs) JMRC. Non-compliance with rules / regulations / notices and laws may be treated as breach of contract and may lead to cancellation of contract and forfeiture of interest free security deposit and other payments.
- ii. The Licensee shall indemnify JMRC from/ against any claims made or damages suffered by JMRC by reason of any default on the part of the Licensee in the due observance and performance of the provisions of any law which may be related to the purpose of this contract and to the area in which spaces are located.
- iii. The Corporation will not be responsible for any accident /theft involving any personnel / equipment of the Licensee / sub Licensee operators while on work. The Licensee itself would be responsible for such accident and also for any kind of compensation to any worker/employee for such accident. The Licensee is advised to have its personnel / assets insured under suitable Insurance Schemes at its own cost.
- iv. The Licensee will bear the cost, throughout the term of the license, for a comprehensive general liability insurance covering injury to or death of any person(s) occurring in the said spaces, including death or injury caused by the sole negligence of the Licensee / sub-licensee or the Licensee's failure to perform its obligations under the agreement.

- v. Upon JMRC's request, the Licensee shall submit to JMRC, suitable evidence that the foregoing insurance policy or policies are in effect. In the event of the default, i.e., avoiding the insurance cover or otherwise, the Licensee agrees and undertakes to indemnify and hold JMRC harmless against any and all liabilities. Losses, damages, claims, expenses suffered by JMRC as a result of such default by the Licensee.
- vi. Obligation for adhering to statutory norms and regulations laid down by any Statutory Body of Central/State Government in connection with installation and operating infrastructure and Telecommunication equipment for mobile coverage shall be vested in the Licensee.
- vii. The fixtures and the equipments thereto installed by the Licensee shall conform to every applicable requirement of law or duly constituted authority or the requirements of the carriers of all insurance on or relating to the licensed spaces. The Licensee at its sole risk and expense, shall at all times during the term thereof promptly comply with all such requirements.
- viii. Any type of statutory taxes applicable on services under this tender process (either in force at present or may be applicable in future by a competent order/notification) will be borne by the selected bidder and the Corporation would not make any payment on this account. In case, the selected bidder fails to comply with any statutory/ taxation liability under appropriate law, and as a result thereof the JMRC is put to any loss/obligation, monetary or otherwise, the JMRC will deduct the same from the Security Deposit of the selected bidder, to the extent of the loss or obligation in monetary terms.
- ix. Obligation for adhering to statutory norms and regulations laid down by any other Statutory Body of Central / State Government in connection with operating Micro Cell shall be vested in the Licensee.
- x. Applications for SACFA/ WPC clearance for each of the radiating equipment set shall be filed by successful bidder in prescribed format to the concerned wing of Department of Telecommunication, GoI as per statutory requirement. Application for Municipal clearance or local body clearance for each of the Micro Cell installation with all requisite documents shall be filed by successful bidder to the concerned local body i.e., Jaipur Nagar Nigam, JDA as per requirement and installation of Micro Cell equipment is to be started only after obtaining necessary clearance from concerned local body and SACFA application ID. JMRC will provide documentation support and extend its help wherever possible relating to JMRC sites for getting local bodies / statutory clearance. However, it will be the sole responsibility of the Licensee to arrange clearance from local bodies / statutory bodies; whenever required.
- xi. Licensee shall ensure compliance of statutory norms of Department of Telecommunication (DoT) or any organisation of DOT by all the telecom operators with whom it is sharing infrastructure.
- xii. The successful Bidder will also be required to take, prior approval from all the relevant authorities, DOT, WPC, TRAI, TERM (legal / statutory), Nagar Nigam, Development Authority, etc., as per the applicable laws of the land for operation of business.

#### 4.8 PAYMENT TERMS OF LICENSE FEES & ELECTRICITY CONSUMPTION CHARGES

- i. The successful bidder shall be required to pay to JMRC Quarterly License fees at the rate quoted in the Bid and approved by JMRC which will be increased by 6 % every year on compounding basis.
- ii. **Payment of license fees shall commence from the 46<sup>th</sup> day after the Notice to Proceed (NTP) is issued**, even if more time is required by the Licensee(s) to complete installation. First 45 days from the day of NTP shall be treated as grace period.
- iii. The first advance quarterly License fees including all other recurring charges shall be paid within 45<sup>th</sup> days of issue of Notice to Proceed (NTP) and if the initial fees date, i.e., 45<sup>th</sup> day of the NTP commences after the 1st of any month of first quarter, then the License fees for that first quarter (quarter according to financial year) shall be calculated on a pro-rata basis.  
However, subsequently from next quarter, the payment of license fees including all other recurring charges for the full quarter shall be made latest by 25<sup>th</sup> of the preceding month of each quarter.
- iv. In case the license agreement(s) is extended beyond the initial 5 years, it will be on same terms & conditions and the license fee shall increase 6% over the amount payable in the previous year. Further, License fee escalation for the extension period (if given) shall also be 6% over the License fees payable in the preceding year.
- v. In addition to the Micro Cell space on metro pillar, if the Licensee needs additional space for utilities and other equipment installations, near the metro pillars or at nearest Metro Stations, and if JMRC is in a position to provide the same, the Licensee shall pay to JMRC additional recurring charges for this additional space as per details given below:

S. No.	Item	Rate (Per month)
1.	License fee for space at nearest Metro Station for backhaul/ equipment (cable/microwave)	Rs.1000 per Sqm. Per month
2.	License fee for space in cable tray	Rs. 10 per meter per month
3.	License fee for laying OF/electrical cable from station over via-duct	Rs. 100 per meter per month

- vi. In addition to above, Licensee will pay additional charges of Rs. 1,000 per month per added operator for more than one operator working for the same Micro Cell space.
- vii. In addition to license fees etc., Licensee is liable to pay necessary GST and all other Central & State Government taxes as applicable from time to time.
- viii. At the time of applying of electrical connection (if being taken from JMRC), the Licensee shall also deposit towards Electric Bill Payment Security (in the form of DD/Banker's cheque), a sum as per Annexure-XI after receipt of the Notice to Proceed. This amount shall be refunded after adjusting any dues on account of electricity consumption upon expiry / termination of license agreement. No interest shall be payable on Electric Bill Payment Security.



- ix. JMRC shall present the bill against electricity consumption on actual usage basis for power conditions, as per the applicable tariff & norms and as per Annexure- XI, to the Licensee. Electricity Consumption Charges shall be payable by the Licensee to JMRC within ten days of issue of bill by JMRC.
- x. For each metro pillars, in case of delay in payment of license fees interest @ 1% per month will be calculated on the outstanding amount for delay less than one month and at 2% per month for more than one month.
- xi. Any delay in payment beyond one month from the due date, shall be considered as a default and such third continuous default may result in termination of this license agreement at the discretion of the licensor.
- xii. In case payment is not made by due date, a notice to remind to clear outstanding dues shall be issued with a caution notice that in the event of failure to clear all the dues a termination notice shall be served to the Licensee for payment of all dues within 30 days. Electricity & other utilities will be disconnected on 16th days of issue of termination notice. A termination order shall be issued after expiry of termination notice along with a notice of 15 days to vacate the spaces failing which all the material shall be seized by JMRC.
- xiii. Any representation or any request by the Licensee shall only be entertained if the Licensee deposits 100% dues as per issue / demand within 15 days of issue of termination notice with applicable interest. No opportunity of any kind will be given in the matter after expiry of termination notice and the contract shall be liable to be terminated.
- xiv. Before commencement of each quarter, the Licensee will give an undertaking / statement, signed by their authorised signatory, mentioning number of telecom operators equipments working with date of commissioning.
- xv. The Licensee has to make all payments as may be due on the due date, without waiting for any formal invoice from the licensor. The Licensee(s) also voluntarily agrees to collect the invoices from the office of the Authorized representative of the licensor (JMRC), if required, before the due date. Non- receipt of invoice will not be consideration for delayed or non-payment of dues and may be treated as a breach of agreement.
- xvi. In no case payments shall be allowed to remain outstanding for a maximum period of three months. If any stage, the dues remain outstanding for the period of more than three months, the license agreement shall be terminated.
- xvii. In case of deposition of license fees & other dues through NEFT/RTGS, the licensee shall intimate JMRC in the format as per Annexure – XIII.

#### **4.9 BREACH OF CONTRACT / LICENSE AGREEMENT**

- i. The Licensee shall abide by the terms and conditions of this RFP and the consequent license agreement. JMRC shall have the right to claim reimbursement of any cost that it may incur due to the breach of any terms and conditions by the Licensee, and may additionally impose justifiable penalty upon the Licensee, which shall not necessarily be limited to the amount of Security Deposits. JMRC shall also have the right to rescind or terminate the Contract / License agreement (in full or part) in the event of such breach.

- ii. Any notice required to be served on the Licensee under this agreement shall be deemed to be served if delivered at the Licensee's address or sent by Registered post /speed post to the Licensee. Similarly, any notice to be given to JMRC under this agreement shall be deemed to have been served if at or sent by Registered post to JMRC. The period of notice given under this Agreement will count from the date of delivery at address (as per receipt of notice by either side) or from date of despatch in case of delivery by registered post, whichever is earlier.

#### **4.10 TERMINATION OF CONTRACT AGREEMENT**

- i. JMRC reserves the right to terminate the Agreement by giving 3 (Three) months advance notice in writing to the Licensee, without assigning any reason thereof. During the notice period Licensee will continue to provide services to mobile operators so as to provide seamless transition to a new Licensee appointed for the purpose. On the termination of the contract, the Licensee shall pay to the JMRC fees for the notice period. In this instance, the interest free security deposit and advance license fees deposited with JMRC shall be refunded adjusting the dues, if any.
- ii. The Licensee shall have the right to terminate the Agreement during the term by giving three 3 (Three) months notice in writing of its intentions after initial lock-in-period of 2 years. In such cases, the advance security deposit shall be refunded after payment of the license fee dues. In case, the Licensee wants to terminate the license before initial lock-in period of two years, the interest free security deposit and advance charges paid will stand forfeited in favour of JMRC. On expiry of the said period the agreement shall stand terminated.

Only on submission of the "no dues certificate" issued by the authorised representative of the JMRC, will any amounts due, if any, other than the interest free security deposit and advance quarterly License fees, will be relicensed to the Licensee.

- iii. Notwithstanding any other rights and remedies provided elsewhere in the Agreement, on termination of this Contract:
  - a. Neither party will represent the other party in any of its dealings. Either party shall not intentionally or otherwise commit any act(s) as would keep a third party to believe that the other party is still providing services as provided under this Contract.
  - b. Both the parties will settle, within seven working days of Termination of this Contract all the outstanding dues of the other party save and except the dues under dispute.
  - c. Each party shall not use each other's name, trademark, brand name, logo, etc. in any audio or visual form after termination of this Contract.
  - d. The expiration or termination of the Contract for any reason whatsoever shall not affect any obligation of either party having accrued under the Agreement prior to the expiration or termination of the Contract and such expiration or termination shall be without prejudice to any liabilities of either party to the other party existing at the date of expiration or termination of the Contract.



#### 4.11 PROHIBITED PRACTICES

- i. The Bidders and their respective officers, employees, agents and advisers shall observe the highest standard of ethics during the Selection Process. Notwithstanding anything to the contrary contained in this RFP, the Authority shall reserve the right not to award Contracts to such Bidder or to cancel the Contracts, if already awarded without being liable in any manner whatsoever to the Bidder, if it determines that the Bidder has, directly or indirectly or through an agent, engaged in corrupt practice, fraudulent practice, coercive practice, undesirable practice or restrictive practice (collectively **“Prohibited Practices”**) in the Selection Process. In such an event, the Authority shall, without prejudice to its any other rights or remedies, forfeit and appropriate the EMD and the Security Deposit, if available, as mutually agreed genuine pre-estimated compensation and damages payable to the Authority for, inter alia, time, cost and effort of the Authority, in regard to the RFP, including consideration and evaluation of such Bidder’s Bid.
- ii. Without prejudice to the rights of the Authority under Clause 4.11 (i) hereinabove and the rights and remedies which the Authority may have under the LOA or the Agreement, if the Bidder or successful bidder, as the case may be, is found by the Authority to have directly or indirectly or through an agent, engaged or indulged in any Prohibited Practice (as defined above) during the Selection Process, or after the issue of the LOA or after the execution of the Contract Agreement, such Bidder or selected bidder shall not be eligible to participate in any tender or RFP issued by the Authority either indefinitely or for a specified period of time, as the case may be, is found by the Authority to have directly or through an agent, engaged or indulged in any such Prohibited Practice.
- iii. For the purposes of this Clause 4.11 the following terms shall have the meaning hereinafter respectively assigned to them:
  - (a) “corrupt practice” means the offering, giving, receiving, or soliciting, directly or indirectly, of anything of value to influence the actions of any person connected with the Bidding Process for this RFP;
  - (b) “fraudulent practice” means a misrepresentation or omission of facts or suppression of facts or disclosure of incomplete facts, in order to influence the Bidding Process for this RFP ;
  - (c) “coercive practice” means impairing or harming, or threatening to impair or harm, directly or indirectly, any person or property to influence any person’s participation or action in the Bidding Process for this RFP;
  - (d) “undesirable practice” means (i) establishing contact with any person connected with or employed or engaged by the Authority with the objective of canvassing, lobbying or in any manner influencing or attempting to influence the Bidding Process for this RFP; or (ii) having a Conflict of Interest; and
  - (e) “restrictive practice” means forming a cartel or arriving at any understanding or arrangement among Bidders with the objective of restricting or manipulating a full and fair competition in the Bidding Process for this RFP.

#### **4.12 CONCILIATION, ARBITRATION & JURISDICTION**

- i. In the event of dispute or difference arising between JMRC and the Licensee out of or in relation to this “license agreement” and so notified in writing by either Party to the other (the “Dispute”), the same shall be discussed in the first instance between the representatives of the Licensee and Director (Corporate Affairs) of JMRC.
- ii. If the dispute is not settled amicably, the matter shall be addressed by the aggrieved party to the Authorized signatory of the other party within 21 days of arising of such a claim. If the issue is not resolved within 30 days of receipt of the claim by the respondent party, the aggrieved party shall refer the claim for Arbitration to Managing Director (MD) of JMRC within 10 days after the passage of this time. The MD, JMRC would appoint the Sole Arbitrator/a panel of Arbitrators of the dispute whose decision shall be final and binding on both the parties. Arbitration proceedings will be assumed to have commenced from the day a written and valid demand for arbitration is received by the MD, JMRC. The place of arbitration will be Jaipur. Wherever applicable, the provisions of the Arbitration and Conciliation Act, 1996 shall apply.
- iii. The courts at Jaipur shall have exclusive jurisdiction over all matters arising out of this tender process or out of the Agreement pursuant to it or out of any arbitration hereunder.
- iv. It will be no bar that the Arbitrator appointed as aforesaid is or has been an employee of the JMRC and the appointment of the Arbitrator will not be challenged or be open to question in any Court of Law, on this account.

#### **4.13 FORCE MAJEURE**

- i. Delay in performance or non-performance of any obligation contained herein shall be excused to the extent such failure or non-performance is caused by force majeure.
- ii. For purposes of this Bid and license agreement(s) to be signed in pursuance of this Bid process, ‘force majeure’ shall mean any cause or event preventing performance of an obligation under this Bid or license agreement(s) under this Bid, which is beyond the reasonable control of either party hereto, and which by the exercise of due diligence, could not have been avoided or overcome, including fire, flood, sabotage, shipwreck, embargo, explosion, terrorist attack, labour trouble, accident, riot, acts of governmental authority (including acts based on laws or regulations now in existence as well as those enacted in the future), acts of God.
- iii. In the event of the Force-Majeure condition(s), either party shall have the option to cancel the contract for the reason of any or all of the Force-Majeure condition(s) notified as above. Further, the Authority shall not be liable to pay to the Bidder, any compensation towards financial implications arising due to Force Majeure.
- iv. As soon as practicable and in any case within 7 days of the date of occurrence of a Force Majeure Event or the date of knowledge thereof, the affected party shall notify other Parties of the same, setting out the details of such Force Majeure Event.
- v. Upon the occurrence of any Force Majeure Event, the following shall apply:
  - a) The Parties shall bear their respective costs and no Party shall be required to pay to the

other Party any costs arising out of such Force Majeure Event.

- b) The Licensee will not be liable to pay the Default Charges for the period for which the Force Majeure events persist.
- vi. Upon the cessation of any Force Majeure Event, the Parties shall immediately resume their respective obligations.
- vii. It is expressly agreed that Agencies ability to provide services to a third party at a more advantageous price or Licensee's economic hardship shall not constitute a force majeure event.

**ANNEXURE – I**
**CHECK LIST**
**ENVELOPE-A [TECHNICAL BID]**

<b>Technical Bid will contain the following documents :</b>		<b>Whether enclosed</b>
1.	This Check List, duly ticked & signed. Shall form part of Technical Bid (Annexure-I)	Yes/No
2.	All pages of RFP Document with corrigendum, addendum if any, duly signed and sealed by the Authorised Signatory of the Bidder Organisation on each page.	Yes/No
3.	Declaration of acceptance of Terms & Conditions of the Request for Proposal (RFP) & SHE Manual, duly filled & signed (Annexure–II)	Yes/No
4.	Bidder’s Profile and bid form, duly filled and signed by authorised signatory (Annexure–III)	Yes/No
5.	Details of MICRO CELL Space(s) Bid for and Bid EMD amount (Annexure–IV)	Yes/No
6.	Draft of License agreement, blank format duly signed (Annexure-V)	Yes/No
7.	Power of attorney in favour of Authorised Signatory, for signing of Bid, duly signed and notarised, if applicable (Annexure –VI) and/or <b>the copy of Board resolution, as applicable.</b>	Yes/No
8.	Bid Security (EMD) in Prescribed form of DD /Banker cheque or Bank guarantee (Annexure-VIII) as calculated in Annexure IV	Yes/No
9.	Format of Bank Guarantee for Performance Security Deposit, duly signed (Annexure-IX)	Yes/No
10.	Format of Bank Guarantee for Installation Security Deposit, duly signed (Annexure-X)	Yes/No
11.	Rules & guidelines for relicense, upkeep & maintenance of electrical power connection in JMRC spaces, duly signed on each page (Annexure-XI)	Yes/No
12.	Indicative drawing of metro pillar (Annexure-XII (1)) duly signed	Yes/No
13.	Indicative photograph of Micro Cell installed on one metro pillar duly signed (Annexure-XII (II))	Yes/No
14.	Valid document(s) issued by competent authority to substantiate that bidder is a Telecom Service Provider or a Registered Telecom Infrastructure Provider (IP-1 Licensee) or ISP etc., as per eligibility	Yes/No

<b>Technical Bid will contain the following documents :</b>		<b>Whether enclosed</b>
	requirement prescribed in Clause 1.3(i) of RFP	
15.	Copy of Income Tax Registration (PAN)	Yes/No
16.	Copy of GST Registration	Yes/No
17.	Bid Document Cost in prescribed form (DD/ Banker cheque/ JMRC Receipt)	Yes/No
18.	Self attested list of similar installations working in India as per eligibility requirement prescribed in Clause 1.3(iii) of RFP.	Yes/No

**Important: It may be ensured that Rates (Financial quotes) are no where disclosed in technical bid, else Technical Bid shall be summarily rejected.**

**ENVELOPE-B [FINANCIAL BID]**

<b>Proposal will contain the following documents :</b>		<b>Whether enclosed</b>
	Annexure – VII: Financial Bid duly filled and signed in prescribed format	Yes/No

Date

Signature

Place

Name

Designation

Seal of Authorised Signatory



**ANNEXURE – II**

**DECLARATION OF ACCEPTANCE OF TERMS & CONDITIONS OF THE RFP**

I/We, ....., having my /our office at....., agree to all the Terms & Conditions the Request For Proposal (RFP) No. **RFP No. F.1 (41)/JMRC/DCA/REV/MICRO CELL/2015-16/06**, dated:19/01/2018 issued by JMRC for LICENSING RIGHTS FOR INSTALLATION & OPERATION OF MICRO CELL ON SELECTED PILLARS OF JAIPUR METRO VIADUCT (Phase-1A) and corrigendum / addendum issued, if any (all the pages of which have been signed by us in token of acceptance of the terms mentioned therein). I/ WE also agree to abide by the relevant terms and conditions of SHE manual of JMRC.

We have enclosed bids as per stipulated procedure and have not disclosed the price bid in other than the financial bid (Envelop-B).

We have gone through carefully and understood the contents of this RFP Document and the information furnished by us is true to the best of our knowledge and belief and nothing has been concealed there from.

Our offer will remain valid and open for acceptance for 90 days from the last date of bid submission.

Date:

Signature:

Place:

Name :

Designation:

Seal of Authorised Signatory

**ANNEXURE – III****BIDDER'S PROFILE & BID FORM**

RFP No. F.1 (41)/JMRC/DCA/REV/ MICRO CELL/2015-16/06

Dated: 19/01/2018

1.	Name of the Bidder Firm	
2.	Status of the Bidder Firm	Proprietorship / Partnership firm / Registered Company
3.	Registered Office address with Contact & Communication details	
4.	Operating/ Branch Office (In Rajasthan, if Registered office is situated out of Rajasthan) Contact details	
5.	Date of registration / incorporation and/or commencement of business	
6.	Registration number/License details as Telecom Operator or a IP Licensee with Department of Telecommunications	
7.	GST Registration No.	
8.	PAN No.	
9.	Name, designation and Contact details of Chief Executive of the firm	
10.	Name, designation and Contact details of the authority that is authorized to sign the Bid document	
11.	Name, designation and Contact details of the Contact Person of the Bidder (Address Phone, email, fax etc).	
12.	Details of Cost of Tender document	





13.	Details of Bid Security	
-----	-------------------------	--

We certify that our organisation has neither been black listed nor our contracts have been terminated/ foreclosed by any company / government department / public sector organisation during last 3 financial years ending 31.03.2017 and during current financial year till date of bid submission, due to non fulfilment of contractual obligations.

Date

Signature

Place

Name

Designation

Seal of Authorised Signatory

**Note: Additional pages, duly signed, may be attached wherever necessary.**

**ANNEXURE – IV**

**DETAILS OF MICRO CELL SPACE(S) BID FOR AND BID SECURITY**

S. N.	Metro Pillar Number	Micro Cell Space Code Number	Whether Bid for (Y/N)	Prescribed (Bid Security) for the MICRO CELL Spaces (in Rs.)	Bid Security being submitted for Micro Cell space bid for
1.	101	MC101		4,000	
2.	102	MC102		4,000	
3.	112	MC112		4,000	
4.	113	MC113		4,000	
Total number of Micro Cell space(s) bid for (1 to 4) =A=>				Total Bid Security for the Micro Cell Spaces bid for amount (Rs.) (A * 4,000)	

**Note:**

1. A Bidder can bid for any number of Micro Cell space(s) as listed above.
2. Bid Security should be carefully calculated and submitted for the number of Micro Cell spaces for which bid is submitted. If the Bid Security submitted is short with reference to the number of Micro Cell spaces Bid for, the entire Bid shall be summarily rejected.

Date

Signature

Place

Name

Designation

Seal of Authorised Signatory

**ANNEXURE – V**

**FORMAT OF LICENSE AGREEMENT**

THIS AGREEMENT is made on this \_\_\_\_\_ day of \_\_\_\_\_ two thousand \_\_\_\_\_ between Jaipur Metro Rail Corporation Limited (JMRC), a Company incorporated under the provisions of the Companies Act, 1956, having its corporate office at Khanij Bhawan, Udyog Bhawan Spaces, Tilak Marg, C-Scheme, Jaipur, hereinafter called the “**LICENSOR**” of the one part, represented by \_\_\_\_\_ (name and designation of representing officer), JMRC, Jaipur, (which term shall, unless excluded by or repugnant to the context, be deemed to include its heirs, representatives, successors and assignees.)

**and**

\_\_\_\_\_ (Name of the successful bidder) represented by \_\_\_\_\_ (name and designation of representing officer) of the other part, hereinafter called the “**LICENSEE**” (which term shall, unless excluded by or repugnant to the context, be deemed to include its heirs, representatives, successors and assignees.)

WHEREAS JMRC is entitled in Law to license out Micro Cell space(s) **at its Metro Stations for the purpose of installation and operations of Micro Cell.**

WHEREAS the Licensee is desirous **to install and operate Micro Cell Telecom equipments at the top of Metro Pillar number (s)**, on the terms & conditions mentioned hereunder and has approached the JMRC for the purpose;

AND WHEREAS the JMRC is agreeable to grant the License;

NOW, THEREFORE, this indenture witnessed:

1. The following documents hereto shall be deemed to form an integral part of this Agreement:
  - (i) Notice to Proceed (NTP) issued by JMRC.
  - (ii) The Letter of Acceptance (LOA) issued by the Corporation in favour of the Licensee.
  - (iii) Addendum and/or Corrigendum to the RFP Document if issued by the Corporation.
  - (iv) The RFP Document (**RFP No. F.1 (41)/JMRC/DCA/REV/MICRO CELL/2015-16/06 Dated: 19/01/2018**) in its entirety along with all its Annexures, Appendices, etc.
  - (v) Safety, Health and Environmental (SHE) Manual of JMRC.

In case of any conflict in the interpretation, the provision of documents shall prevail in the order or their place in the list above.

2. That the License for the said Space shall be valid for the period of 5 (five) years from the 46<sup>th</sup> day of issue of NTP unless terminated earlier as provided in the RFP.
3. That in consideration, Licensee shall pay to the Licensor every quarter License fees, latest by 25<sup>th</sup> of the preceding month of each quarter, a sum as under:

Year	Monthly payable license fees* (In Rs.)
I	
II	
III	
IV	
V	

\* GST shall be payable extra by Licensee, as applicable

4. In addition to the Micro Cell space on metro pillar, if the Licensee needs additional space for utilities and other equipment installations, near the metro pillars or at nearest Metro Stations, and if JMRC is in a position to provide the same, the Licensee shall pay to JMRC additional recurring charges for this additional space as per details given below:

S. No.	Item	Rate (Per month)
1.	License fee for space at nearest Metro Station for backhaul/equipment (cable/microwave)	Rs.1000 per Sqm. Per month
2.	License fee for space in cable tray	Rs. 10 per meter per month
3.	License fee for laying OF/electrical cable from station over via-duct	Rs. 100 per meter per month

5. Licensee will pay additional charges of Rs. 1,000 per month per added operator for more than one operator working for the same Micro Cell space.
6. The first advance quarterly License fees including all other recurring charges shall be paid within 30<sup>th</sup> days of issue of Notice to Proceed (NTP) and if the initial fees date, i.e., 46<sup>th</sup> day of the NTP commences after the 1st of any month of first quarter, then the License fees for that first quarter (quarter according to financial year) shall be calculated on a pro-rata basis.

However, subsequently from next quarter, the payment of license fees including all other recurring charges for the full quarter shall be made latest by 25<sup>th</sup> of the preceding month of each quarter.

7. That in the event of the Licensee committing any breach of the terms & conditions of the **RFP No. F.1 (41)/JMRC/DCA/REVENUE/MICRO CELL-JMRC PILLARS/2015-16/06 Dated: 19/01/2018** alongwith corrigendum/amendment, if any, preceding this License agreement, Licensor shall without prejudice to other rights and remedies be entitled to forfeit the Security Deposits or any part thereof. In such an event the Licensee shall pay in the same manner as stated above such additional sum immediately as he may be called upon by licensor to pay, so that the Security Deposits shall at all times during the continuance of these presents, be for the same amount. On the expiration or earlier determination of the License, the licensor shall return the Security Deposit, to the Licensee, without interest.

8. That the Licensee shall equip himself with all necessary permits, licenses and such other permissions as may be required under the law in force at any time with regard to the operation of the subject License.
9. That the licensor shall provide bare space for the installation of the telecommunication infrastructure by the Licensee. All other requirements like fixtures etc. shall be arranged by the Licensee, at its own cost and efforts.
10. That it shall be the responsibility of the Licensee at all the times during the currency of the license agreement to obtain adequate fire, theft and burglary insurance coverage in respect of all its movable and immovable assets in the License spaces and the licensor shall not be responsible for any loss or damage caused to the Licensee on any accounts whatsoever.
11. That the Licensee shall use the designated space only for the bona fide purpose as mentioned in the RFP and recitals in this Agreement, and for no other purpose.
12. That the Licensee shall not display any advertisement.
13. That considering the stipulated provisions on electric safety at Metro spaces, the Licensee shall adhere to Rules and Guidelines for relicensing, upkeep and maintenance of electric power as detailed in Annexure-XI of the RFP preceding to this license agreement.
14. That the licensor and the Licensee further agree that they are bound by the terms and conditions of the **RFP No.F.1(41)/JMRC/DCA/REV/MICRO CELL/2015-16/06** dated 19/01/2018 (including any corrigenda and/or addenda thereof.) In case of any conflict between the RFP (including any corrigenda and/or addenda thereof) and this license Agreement, the latter shall prevail insofar as the spirit of the RFP is not affected thereby.

In witness whereof, the Parties hereto have caused this Agreement to be signed in their respective names as of the day and year first above written.

Authorised Signatory

For Jaipur Metro Rail Corporation Ltd.

Authorised Signatory

For \_\_\_\_\_(Licensee)

Witness:

a) Name and Address

b) Name and Address

**Note:** This agreement should be executed on non-judicial stamped paper, stamped in accordance with the stamp act.



**ANNEXURE-VI**

**FORMAT FOR POWER OF ATTORNEY FOR SIGNING OF APPLICATION**

Know all men by these presents, we, ..... (name of the bidder firm), having our registered office at..... do hereby irrevocably constitute, nominate, appoint and authorise Mr./Ms..... son /daughter of Shri ..... and presently residing at ....., who is presently employed with us and holding the position of ....., as our true and lawful attorney (hereinafter referred to as the "Attorney") to do in our name and on our behalf, all such acts, deeds and things as are necessary or required in connection with or incidental to submission of our bid for **“Licensing Rights For Installation & Operation Of Micro Cell On Selected Pillars Of Jaipur Metro Viaduct (Phase-1A)” (RFP No. F.1 (41)/JMRC/DCA/REV/ MICRO CELL/2015-16/06 dated 19/01/2018)** including but not limited to signing and submission of all applications, bids and other documents and writings, participate in bidders and other conferences and providing information / responses to the Authority, representing us in all matters before the Authority, signing and execution of all contracts including the Contract Agreement and undertakings consequent to acceptance of our bid, and generally dealing with the Authority in all matters in connection with or relating to or arising out of our bid for the said Project and/or upon award thereof to us and/or till the entering into of the Contract Agreement with the Authority.

AND we hereby agree to ratify and confirm and do hereby ratify and confirm all acts, deeds and things done or caused to be done by our said Attorney pursuant to and in exercise of the powers conferred by this Power of Attorney and that all acts, deeds and things done by our said Attorney in exercise of the powers hereby conferred shall and shall always be deemed to have been done by us.

IN WITNESS WHEREOF WE,....., THE ABOVE NAMED PRINCIPAL HAVE EXECUTED THIS POWER OF ATTORNEY ON THIS ..... DAY OF ..... / 2017.

For.....

(Signature, Name, Designation and Address)

Accepted

(Signature, Name, Designation and Address of Attorney)

Witnesses:

- 1. XXX
- 2. ABC

Note:

- 1. The mode of execution of the Power of Attorney should be in accordance with the procedure, if any, lay down by the applicable law and the charter documents of the executants(s) and when it is so required the same should be under common seal affixed in accordance with the required procedure.
- 2. This should be executed on non-judicial stamped paper, stamped in accordance with the stamp act.

**ANNEXURE-VII**

RFP No. F.1 (41)/JMRC/DCA/REV/ MICRO CELL/2015-16/06

Dated: 19/01/2018

**FORMAT OF FINANCIAL BID / BOQ**

Validate

Print

Help

**Percentage BoQ****Tender Inviting Authority:** Executive Director (Corporate Affairs), JMRC**Name of Work:** Licensing Rights For Installation & Operation Of Micro Cell On Selected Pillars Of Jaipur Metro Viaduct (Phase – 1A)**Contract No:** F.1 (41)/JMRC/DCA/REV/ MICRO CELL/2015-16/06 Dated: 19/01/2018

Bidder Name :						
<b>PRICE SCHEDULE:</b> (This BOQ template must not be modified / replaced by the bidder and the same should be uploaded after filling the relevant columns, else the bidder is liable to be rejected for this tender. Bidders are allowed to enter the bidder Name and Values only )						
<b>NOTE: The bidder who quotes the highest percentage shall be considered as successful bidder.</b>						
NUMBER #	TEXT #	NUMBER #	TEXT #	NUMBER	NUMBER #	TEXT #
Sl. No.	Item Description	Quantity	Units	Base Rate (in Rs. per month)	TOTAL AMOUNT Without Taxes (in Rs. Per year)	TOTAL AMOUNT In Words (in Rs.)
1	2	4	5	6	53	55
1.01	MC-101 MC-102 MC-112 MC-113	1 1 1 1	Number	3000 3000 3000 3000	36000 36000 36000 36000	12000
<b>Total in Figures</b>		4	Numbers		<b>144000</b>	(One Lac Forty Four Thousand Only)
<b>Quoted Rate in Figures</b>			<b>Select Excess(+) Less (-)</b>		<b>0.0000</b>	INR Zero Only
<b>Quoted Rate in Words</b>			<b>INR Zero Only</b>			

**Terms and Conditions:**

1. A bidder can submit bid for any number of micro cell spaces listed above and accordingly he has to submit EMD and give details in Annexure-IV.
2. The quoted percentage shall be applicable to individual rate of each of the Micro Cell spaces.
3. The License Fee quoted above is/are after taking into consideration all the terms and conditions stated in the RFP and based on our own estimates of costs, commuters, non-commuters, and after a careful assessment of the site and all the conditions that may affect the bid.
4. The GST or any other tax on the license fee, if levied by the Govt., shall be borne by the Licensee (successful bidder).

Date  
PlaceSignature  
Name  
Designation  
Seal of Authorised Signatory

**Note:** This sheet is to be signed blank and no rate should be quoted here. The rates are to be quoted in downloaded BOQ sheet (soft copy) only. The bid will be summarily rejected in case rates are disclosed in technical bid.



**ANNEXURE – VIII**

**FORMAT OF BANK GUARANTEE FOR EARNEST MONEY DEPOSIT (BID SECURITY)**  
**(to be submitted by the bidder along with bid)**

To,

Chairman and Managing Director,  
Jaipur Metro Rail Corporation Limited (JMRCL),  
Khanij Bhawan, Udyog Bhawan,  
Tilak Marg, C-Scheme, Jaipur-302005 (Raj).

Sir,

In accordance with your RFP for “**Licensing Rights For Installation & Operation Of Micro Cell On Selected Pillars Of Jaipur Metro Viaduct (PHASE-1A)**” vide RFP No. F.1 (41)/JMRC/DCA/REV/ MICRO CELL/2015-16/06 dated: 19/01/2018 M/s. .... (Name & full address of the firm) (hereinafter called the “Bidder”) intends to submit a Bank Guarantee to participate in the said tender as mentioned in the RFP document.

It is a condition in the RFP document that the Bidder has to deposit Earnest Money amounting to Rs.\_\_\_\_\_/ - (Rupees \_\_\_\_\_ only) in respect to the tender, with Jaipur Metro Rail Corporation, Jaipur (hereinafter referred to as “JMRC”) by a Bank Guarantee from a Scheduled Bank having its branch at Jaipur irrevocable and operative till 30 days after the bid validity date (i.e.120 days from the last date of bid submission). It may be extended if required in concurrence with the bid validity.

And whereas the Bidder desires to furnish a Bank Guarantee for a sum Rs.\_\_\_\_\_ (Rupees\_\_\_\_\_ only) to the JMRC as earnest money deposit.

And whereas the bidder has approached the ..... (Bank) for such purpose.

2. Now, therefore, we the ..... (Bank), a body corporate constituted under the Banking Companies (Acquisition and Transfer of Undertaking) Act. 1969 (delete, if not applicable) and branch Office at..... (Hereinafter referred to as the Guarantor) do hereby undertake and agree to pay forthwith on demand in writing by the JMRC of the said guaranteed amount without any demur, reservation or recourse.
3. We, the aforesaid bank, further agree that the JMRC shall be the sole judge of as to whether the Bidder has committed any breach or breaches of any of the terms costs, charges and expenses caused to or suffered by or that may be caused to or suffered by the JMRC on account thereof to the extent of the Earnest Money required to be deposited by the Bidder in respect of the said RFP Document and the decision of the JMRC that the Bidder has committed such breach or breaches and as to the amount or amounts of loss, damage, costs, charges and expenses caused



to or suffered by or that may be caused to or suffered by the JMRC shall be final and binding on us.

4. We, the said Bank further agree that the Guarantee herein contained shall remain in full force and effect until it is relicensed by the JMRC and it is further declared that it shall not be necessary for the JMRC to proceed against the Bidder before proceeding against the Bank and the Guarantee herein contained shall be invoked against the Bank, notwithstanding any security which the JMRC may have obtained or shall be obtained from the Bidder at any time when proceedings are taken against the Bank for whatever amount that may be outstanding or unrealized under the Guarantee.
5. Any notice by way of demand or otherwise hereunder may be sent by special courier, telex, fax, registered post or other electronic media to our address, as aforesaid and if sent by post, it shall be deemed to have been given to us after the expiry of 48 hours when the same has been posted.
6. If it is necessary to extend this guarantee on account of any reason whatsoever, we undertake to extend the period of this guarantee on the request of our constituent under intimation to you.
7. The right of the JMRC to recover the said amount of Rs. \_\_\_\_\_/- (Rupees \_\_\_\_\_ only) from us in manner aforesaid will not be precluded/ affected, even if, disputes have been raised by the said M/s. ....(Bidder)and/ or dispute or disputes are pending before any court, authority, officer, tribunal, arbitrator(s) etc..
8. Notwithstanding anything stated above, our liability under this guarantee shall be restricted to Rs. \_\_\_\_\_/- (Rupees \_\_\_\_\_ only) and our guarantee shall remain in force till 30 days of the bid validity period i.e. 150 days from the last date of bid submission and unless a demand or claim under the guarantee is made on us in writing within three months after the Bid validity date, all your rights under the guarantee shall be forfeited and we shall be relieved and discharged from all liability there under.
9. This guarantee shall be governed by and construed in accordance with the Indian Laws and we hereby submit to the exclusive jurisdiction of courts of Justice in India for the purpose of any suit or action or other proceedings arising out of this guarantee or the subject matter hereof brought by bidder may not be enforced in or by such court.
10. We hereby confirm that we have the power/s to issue this Guarantee in your favour under the Memorandum and Articles of Association/ Constitution of our bank and the undersigned is/are the recipient of authority by express delegation of power/s and has/have full power/s to execute this guarantee under the Power of Attorney issued by the bank in your favour.

Place: .....

Date: ..... (Signature of the Bank Officer)

Rubber stamp of the bank

Authorized Power of Attorney Number: .....

Name of the Bank officer: .....

Designation: .....

Complete Postal address of Bank: .....



.....  
Telephone Numbers .....  
Fax numbers .....

Note:

1. This guarantee should be issued on non-judicial stamp paper, stamped in accordance with the Stamps Act.
2. The stamp papers of appropriate value shall be purchased in the name of the Licensee.
3. Bank should separately send through registered post/courier a certified copy of Bank Guarantee, mentioning Bid reference, Bid title and bidder name, directly to JMRC at the following address:

Executive Director (Corporate Affairs)  
Jaipur Metro Rail Corporation Ltd.  
2<sup>nd</sup> Floor, RSIC Wing, Udyog Bhawan,  
Tilak Marg, C-Scheme, Jaipur-302005.

**ANNEXURE-IX**

**FORMAT OF BANK GUARANTEE FOR PERFORMANCE SECURITY DEPOSIT**

(to be submitted by the successful bidder at the time of agreement)

In consideration of Jaipur Metro Rail Corporation Limited, Jaipur (hereinafter called JMRC) having agreed to exempt \_\_\_\_\_ (hereinafter called the Selected Bidder) from the **demand of security deposit of Rs. \_\_\_\_\_ on production of Bank Guarantee for Rs. \_\_\_\_\_** for the due fulfillment by the Selected Bidder of the terms & conditions to be contained in a License agreement signed pursuant to the **RFP No. F.1 (41)/JMRC/DCA/REV/ MICRO CELL/2015-16/06** dated: 19/01/2018 issued by JMRC for “**Licensing Rights For Installation & Operation Of Micro Cell On Selected Pillars Of Jaipur Metro Viaduct (PHASE-1A)**” we, \_\_\_\_\_ (name of the Guaranteeing Bank, hereinafter referred to as “the Bank”) at the request of \_\_\_\_\_ (Selected Bidder) do hereby undertake to pay to JMRC, JAIPUR, an amount not exceeding Rs. \_\_\_\_\_, against any loss or damage caused to or suffered by, or which could further be caused to or suffered by, JMRC, JAIPUR, \_\_\_\_\_ by reason of any breach by the Selected Bidder of any of the terms & conditions contained in the said License agreement or RFP, or against any penalty imposed by JMRC on the Selected Bidder on such grounds.

2. We \_\_\_\_\_ (name of the Bank) do hereby undertake to pay the amounts due and payable under this guarantee without any demur, merely on a demand from JMRC, JAIPUR, stating that the amount claimed is due by way of loss or damages caused to or suffered by or which could further be caused to or suffered by JMRC, JAIPUR or by way of penalty imposed on the Selected Bidder by JMRC, on account of breach by the Selected Bidder of any of the terms & conditions contained in the Contract Agreement or RFP or by reason of the Selected Bidder’s failure to perform the said Agreement. Any such demand made on the Bank shall be conclusive as regards the amount due and payable by the Bank under this guarantee where the decision of JMRC, JAIPUR, in these counts shall be final and binding on the Bank. However, our liability under this guarantee shall be restricted to an amount not exceeding Rs. \_\_\_\_\_.
3. We \_\_\_\_\_ (name of the Bank) undertake to pay to JMRC, JAIPUR, any money so demanded notwithstanding any disputes raised by the Selected Bidder in any suit or proceeding pending before any court or tribunal relating thereto, our liability under the present being absolute and unequivocal. The payment so made by us under this bond shall be valid discharge of our liability for payment there-under and the Selected Bidder shall have no claim against us for making such payment.
4. We \_\_\_\_\_ (name of the Bank) further agree that the guarantee herein contained shall remain in full force and effect immediately for a period of **69 Months** from date herein and further agree to extend the same from time to time so that it shall continue to be enforceable till all the dues of JMRC, JAIPUR, under or by virtue of the said agreement have either been fully paid and its claims satisfied or discharged, or till JMRC, JAIPUR, certifies that the terms & conditions of the Contract agreement and RFP have been fully and properly carried out by the Selected Bidder and accordingly discharges this guarantee.



5. We \_\_\_\_\_ (name of the Bank) further agree with JMRC, JAIPUR, that JMRC, JAIPUR, shall have the fullest liberty without our consent and without affecting in any manner our obligations here under to vary any of the terms & conditions of the License agreement and to forbear or enforce any of the terms & conditions relating to the Contract agreement or RFP and we shall not be relieved from our liability by reason of any such variation or for any forbearance, and /or any omission on the part of JMRC, JAIPUR, or any indulgence by JMRC, JAIPUR, to the Selected Bidder or by any such matter or thing whatsoever which under the law relating to sureties would, but for this provision, have effect of so relieving us.
6. This guarantee will not be discharged due to the change in the constitution of the Bank or the Selected Bidder.
7. This guarantee shall be irrevocable and the obligations of the Bank herein shall not be conditional to any prior notice by JMRC, JAIPUR.

Place: .....

Date: ..... (Signature of the Bank Officer)

Rubber stamp of the bank

Authorized Power of Attorney Number: .....

Name of the Bank officer: .....

Designation: .....

Complete Postal address of Bank: .....

.....

Telephone Numbers .....

Fax numbers .....

Note:

1. This guarantee should be issued on non-judicial stamp paper, stamped in accordance with the Stamps Act.
2. The stamp papers of appropriate value shall be purchased in the name of the Licensee.
3. Bank should separately send through registered post/courier a certified copy of Bank Guarantee, mentioning Bid reference, Bid title and bidder name, directly to JMRC at the following address:

Executive Director (Corporate Affairs)  
 Jaipur Metro Rail Corporation Ltd.  
 2<sup>nd</sup> Floor, RSIC Wing, Udyog Bhawan,  
 Tilak Marg, C-Scheme, Jaipur-302005.

**ANNEXURE-X**

**FORMAT OF BANK GUARANTEE FOR INSTALLATION SECURITY DEPOSIT**

(to be submitted by the successful bidder at the time of agreement)

**To:**

Chairman and Managing Director,  
Jaipur Metro Rail Corporation Limited (JMRC),  
Khanij Bhawan, Udyog Bhawan ,  
Tilak Marg, C-Scheme,  
Jaipur-302005 (Raj).

**WHEREAS** \_\_\_\_\_

\_\_\_\_\_ (Name and address of the Licensee) (hereinafter called “**the Licensee**”) has undertaken to fulfil the contractual obligations to be contained in the License agreement signed pursuant to the RFP No. F.1 (41)/JMRC/DCA/REV/ MICRO CELL/2015-16/06 dated: 19/01/2018 issued by JMRC for “**Licensing Rights For Installation & Operation Of Micro Cell On Selected Pillars Of Jaipur Metro Viaduct (PHASE-1A)**”

**AND WHEREAS** it has been stipulated by you in the said License agreement that the Licensee shall furnish you with a Bank Guarantee from a Scheduled Bank based in India for the sum specified herein as security for compliance with his obligations in accordance with the Contract.

**AND WHEREAS** we \_\_\_\_\_  
(Insert name and address of Bank) have agreed to give the Licensee such a Bank Guarantee:

**NOW THEREFORE** we hereby affirm that we are the Guarantor and responsible to you, on behalf of the Licensee up to a total of Rs. \_\_\_\_\_ (In figures) Rupees \_\_\_\_\_ (In words) (amount of Guarantee) such sum being payable in the types and proportion of currencies in which the License fees and other charges are payable and we hereby unconditionally, irrevocably and without demur undertake to immediately pay you, upon your first written demand and without cavil or argument any sum or sums within the limits of Rupees \_\_\_\_\_ (amount of guarantee) as aforesaid without your needing to prove or to show grounds or reasons for your demand for the sum specified therein.

We hereby waive the necessity of your demanding the said debt from the Licensee before presenting us with the demand.



We further agree that no change or addition to or other modification of the terms of the contract or of the works to be performed there under or of any of the contract documents which may be made between you and the Licensee shall in any way relicense us from any liability under the guarantee and we hereby waive notice of any such change, addition or modification.

This guarantee shall be valid for nine months from the date of issue of this Bank Guarantee. The pendency of any dispute or arbitration or other proceedings shall not affect this guarantee in any manner.

Place: .....

Date: ..... (Signature of the Bank Officer)

Rubber stamp of the bank

Authorized Power of Attorney Number: .....

Name of the Bank officer: .....

Designation: .....

Complete Postal address of Bank: .....

.....

Telephone Numbers .....

Fax numbers .....

Note:

1. This guarantee should be issued on non-judicial stamp paper, stamped in accordance with the Stamps Act.
2. The stamp papers of appropriate value shall be purchased in the name of the Licensee.
3. Bank should separately send through registered post/courier a certified copy of Bank Guarantee, mentioning Bid reference, Bid title and bidder name, directly to JMRC at the following address:

Executive Director (Corporate Affairs)  
 Jaipur Metro Rail Corporation Ltd.  
 2<sup>nd</sup> Floor, RSIC Wing, Udyog Bhawan,  
 Tilak Marg, C-Scheme, Jaipur-302005.



## ANNEXURE-XI

### **RULES & GUIDELINES FOR RELICENSE, UPKEEP & MAINTENANCE OF ELECTRICAL POWER CONNECTION IN JMRC SPACES**

1. Electric power required for commercial / contractual activities within footprint of metro station/ premises have to be sourced from existing available JMRC network only at stations subject to its technical feasibility. The disbursement of electric power at different stations shall be dealt with individually under separate connections. In case of Roof Top Towers and all kinds of telecom towers, the Licensee shall have option of taking direct electric power connection from JVVNL. Further, for large retail areas (category-B), the Licensee shall have to take electric power connection directly from JVVNL while meeting out all the requirements for electrical safety, fire safety and shall obtain NOCs from concerned authorities.
2. The available JMRC power network is reliable and having adequate redundancy. DG supply shall not be made available i.e. the power fed shall be from normal JVVNL source without backup network. Licensee may however, provide UPS / Inverter at their cost if they so desire for backup supply to their Licensed premises/ works requirement.
3. Installation of DG set for normal/ standby power by Licensee/ private parties is not permitted. The Licensee may use suitable voltage stabilizer(s)/ power factor correction equipment as per its requirement. Further, JMRC shall not be responsible for any interruption/ diminution of the power supply.
4. Normally, electric power up to maximum demand of 20 kW on LT Three Phase 400 Volt can be reLicensed. However, LT Single Phase 230 V supply will be given for connected load up to 5 KW, subject to its technical feasibility.
5. Application for temporary/ permanent electric connection is to be made (addressed) to General Manager (Traction/E&M), JMRC in the prescribe Performa appended to these Rules & Guidelines, clearly stating the purpose for taking the connection, enclosing the documentary proof of having awarded contract by JMRC for which they need the electric supply, mentioning the site details where connection is required and the load in KW and the period for which connection is applied for.
6. Temporary connections shall be reLicensed by JMRC from nearest source point with sub-metering arrangements. Permanent connection for retail space shall be reLicensed from extended supply point which shall be installed by JMRC adjacent/ near/ inside the retail space/PAP Panel at ASS as per technical feasibility.
7. In case of advertisement kiosk/ hoardings inside or outside the station premises, the power supply shall be extended from a single supply point to a group of kiosk/ hoardings, depending upon the load & technical feasibility. The supply point shall be provided by JMRC near to the load center/PAP Panel at ASS as per feasibility. The licensee (of advertisement contract) shall extend & maintain the power supply at their own from the supply point to the

load(s).

**8. ReLicense of temporary connection:**

8.1. Temporary connection may be given in following cases:-

i.	At the time of setting up the retail shop/ Kiosks etc., for related construction activity before Permanent connection.
ii.	For any exhibition, display of products etc. for very short period.

8.2. Initially, temporary connection shall be given up to 30 days. During these 30 days, Rs.100/- per week per KW or part thereof shall be charged (temporary connection charges) over and above applicable tariff (Rate of electricity shall be charged from Licensee at JVVNL tariff applicable for the purpose to JMRC) to take care of expenditure done by JMRC for reLicense of electric connection.

8.3. All electrical works for temporary connection beyond this source/ supply point (JMRC sub meter) shall be undertaken by the Licensee, confirming to electrical safety and technical suitability as certified by authorized representative of JMRC.

8.4. In case of extension of the temporary connection beyond 30 days, temporary connection charges shall be doubled for the extended period.

8.5. Electrical Security Deposit for tentative consumption of electricity for one month @ Rs. 6000/- per KW shall have to be deposited by Licensee before reLicense of temporary connection. Billing shall be done as per applicable tariff at the end of month/ period of temporary connection, whichever is earlier and Licensee shall have to deposit the bill amount within seven days of issue of bill, failing which, the electric connection shall be disconnected without any prior notice. The reconnection of electricity shall be done after depositing the due bill amount along with a token penalty of Rs. 2000/- in each case.

8.6. The electrical security deposit shall be adjusted/ refunded at the end of the period of temporary connection to Licensee.

**9. ReLicense of Permanent Connection:**

9.1. Following works shall be carried out by JMRC for reLicense of permanent electrical connection to retail areas/advertisement panels/ mobile towers etc:

i.	Supply and laying including end termination of suitable size (rating suitable for allowable electric load) LT FRLS cable (from source to nearest point as per feasibility) as per standard specifications.
ii.	Supply and lying of meter box, pre/post-paid energy meter and MCB for extending the power.
iii.	Connection to advertising licensee for illuminated boards/ panels shall be given at one point on each entry/exit at ground/concourse level and at each platform with provision of meter(s) as per technical feasibility. Extension of electric supply from these points to advertisement board / panels shall be done by licensee at their own

	cost. Each of such electric point shall be considered one electric connection. The wiring shall have to be done as per JMRC specification with use of wires / conduits / switchgears of standard brands / makes approved by JMRC.
iv.	Electric connection to various mobile towers or other installations on roof / outside covered area shall be given from PAP panel in ASS. Provision of meter can be made either in ASS or near to installation of Licensee as per JMRC convenience. All works of cabling / wiring from PAP panel to his installation shall be done by Licensee at his own cost with use of material such as cables / wires / switchgears of standard brands / makes approved by JMRC and the work shall have to be carried out as per JMRC's specifications and under supervision of E&M department of JMRC.
9.2.	<p>Licensee is required to pay a lump-sum amount (non-refundable) given below towards the cost of electrical works / augmentation work required for extension of power from JMRC panel/ DB up to JMRC meter box, adjacent/ near/PAP panel in ASS to the Licensed space: –</p> <ol style="list-style-type: none"> <li>I. For 5 KW load – Rs. 30,000</li> <li>II. For 10 KW load – Rs. 40,000</li> <li>III. For 15 KW load – Rs. 50,000</li> <li>IV. For 20 KW load – Rs. 60,000</li> </ol> <p>The lump sum installation charges are to be payable by Licensee against each single connection for installation and maintenance thereof, during the contract/ extended contract period. No additional installation charge should be paid during the extended contract period. However during contract period any replacement/ renewal of installations, due to licensee's fault/ negligence shall be done by JMRC at the cost of Licensee.</p>
9.3.	Licensee shall extend power supply from JMRC Meter at his own cost as per approved makes and specifications. Licensee is also required to comply with necessary provision for fire safety norms of JMRC. The Licensee shall execute electrical works within the Licensed space at his own with prior in-principle approval for electrical safety scheme by JMRC.
9.4.	Permanent connection shall be given after ensuring all safety compliance and completion of electrical and fire safety works in all respect by the applicant. JMRC representative shall inspect the electrical installation work executed by the JMRC Licensee before reLicense of electrical connection.
9.5.	Applicant shall ensure that fire detection and suppression measures installed inside premises are kept in good working conditions at all times.
9.6.	Electrical Security Deposit of Rs.30,000 for 5kW and Rs.10,000 per 5 kW - for additional load upto 20 kW shall have to be deposited by the applicant before reLicense of permanent connection. Billing shall be done as per the applicable tariff (Rate of electricity shall be charged from Licensee at JVVNL tariff applicable for the purpose to JMRC) at the end of each month and

Licensee shall have to deposit the billed amount within ten days of issue of bill, failing which, the electric connection shall be disconnected without any prior notice. The reconnection of electricity shall be done after depositing the due bill amount along with a token penalty of Rs. 2000.

The electrical security deposit shall be adjusted/ refunded at the end of the period of permanent connection to Licensee.

10. Underground metro stations are already air-conditioned and hence separate AC for Licensed premises in that area is not required. In underground stations, installations of window/ split AC are not permitted. At some of the retail spaces, tapping of connection from chilled waterline shall be required. Such works after tapping point shall be done by Licensee.
11. For elevated stations Licensee may provide AC at his own cost conforming to detailed specifications of JMRC and within the sanctioned load to them.

12. **Specifications for Electrical Works**

- i. All the electrical work done within the Applicant's premises including wiring, power outlets and gadgets are to be used and maintained properly for guarding against short circuits/fires and are as per the Indian Electricity Rule, 1956 and other applicable laws, statutory provisions and standards in force at the time, and indemnify JMRC against any loss accrued to the Applicant on this account.
- ii. Only FRLS cable of required size shall be used for tapping off supply from JMRC fixed supply to Applicant premises in rigid GI Conduit pipe. However for underground station FRLSZH cable shall be used. Use of PVCs is strictly prohibited in underground station area. The wiring scheme, the type of wiring, size of wires, various loads, plug point, light fan etc. shall be as per JMRC's approval.
- iii. Cables upto 6 Sq.mm will be of copper conductor and above 6 Sq.mm Aluminium conductors may be used. However in case of underground station, use of Aluminium conductor cable is not allowed. Cables for single phase shall be three core, with one core as earth. For three phase load, four core cable along with separate 2 nos. of 8 SWG GI wires shall be used for earthing. For underground stations, 2 separate earth wire of 8 SWG copper conductor shall be used.
- iv. For elevated stations, all wires shall be FRLS. Cables shall be armoured, XLPE, FRLS. In case of Underground stations, all wires and cables shall be armoured, XLPE FRLSZH and conform to NFPA-70, BS-6724 and BS6724
- v. Applicant will provide a separate protection for their electric requirement with proper discrimination with upstream breaker.
- vi. All materials specification must follow standards, codes and specification as used by JMRC in the E&M works. Applicant shall use reputed Brand/make Electrical wiring and switch gear items. List of approved makes by JMRC is given below:

**List of Approved Makes:**

SN	Item	Approved Makes
1.	GI Conduit Pipes	ISI Marked
2.	GI Conduit Accessories	Confirming to BIS/ISI as per approved samples
3.	Copper Conductor FRLS, PVC insulated wires (ISI mark)	National, Ecko, Finolex, Havells, Grandly, NICCO, Asian, Poly Cab
4.	Copper Conductor FRLSZH , PVC insulated wires (ISI mark) use for underground station	Polycab, Ducab Dubai, Cords Cables, KEI.
5.	FRLS Cables Al (ISI mark)	Fort Gloster, NICCO, Finolex, Asian/RPG, KEI, Havells, Polycab, CCI, Universal
6.	FRLS Cables Al (ISI mark)	Fort Gloster, NICCO, Finolex, Asian/RPG, KEI, Havells, Polycab, CCI, Universal
7.	FRLSZH , PVC Cables Al (ISI mark) use for underground station	Polycab, Ducab Dubai, Cords Cables, KEI, RashiCables.
8.	Switches & Socket outlets(ISI mark)	Crabtree, Anchor, MDS, LK (Schneider), RK, Legrand
9.	MCB, RCCB (ELCB)	L&T Hager, MDS, Siemens, GE, Merlin-Gerin, ABB, Schnieder, Standard, Indo-Asian, Havells
10.	Distribution Boards	L&T Hager, MDS, Siemens, ABB, Indo-Asian, Havells, GE, Schnieder, Standard
11.	Luminaries	Philips / Schrader / Osram / Bajaj / Thorn / Crompton
12.	Air Conditioner (Minimum three star rating)	Hitachi, Blue Star, O-General, Daikin, Voltas, LG, Samsung,

In case electrical items of any other make, the same needs to be approved from JMRC before installation.

- vii. Only Galvanized Cable tray, Conduit, Cable Ladder shall be allowed.
- viii. Internal wiring of luminaries (Light Fittings) and Signages in signage's panel shall also be FRLSZH in case of UG stations.

- ix. All Plastic accessories used in luminaries shall be non-flammable material, meeting all the NFPA requirements, preferable by UV and shall be suitable for application at UG station conforming to UL – 94 standards on flammability of material.

13. **Other Terms and Conditions:**

- 13.1. The Applicant shall pay for the energy so supplied and all other charges at the rates set out by JVVNL Tariff Schedule and the miscellaneous charges for supply as may be in force from time to time, including advance Electrical Security Deposit.
- 13.2. The electrical connection shall be applied & reLicensed in the name of Licensee only. In case Licensee has sub-let the premises/ space to any franchise/ sub-Licensee, the onus of payment of electricity bills etc. and adhering to the Rules & Guidelines of electrical safety & maintenance will be of Licensee only.
- 13.3. The Applicant shall have no objection for the DISCOMs to carry out Inspections of the Applicants' Meters & Equipments any Observation made by such Agencies, which are acceptable to JMRC, shall be binding on the Applicant for Attention/Compliance.
- 13.4. JMRC shall be entitled to disconnect the supply of energy by issuing a disconnection notice in writing, to the Applicant, if the Applicant is in default of payment of the due charges.
- 13.5. The applicant shall pay the full amount mentioned in the Monthly/Bi-monthly Consumption Bill as raised by JMRC before the last date mentioned in such Monthly./Bi-monthly Bill.
- 13.6. All or any taxes/duties, as may be levied on the supply of electricity to the Applicant by JMRC, shall be paid and borne by the Applicant.
- 13.7. The Applicant agrees that JMRC would accept an application from the Applicant for reduction in load only after one years from the original sanction. All applications for load enhancement by the Applicant would be dealt with by JMRC as a new connection and JMRC would follow the procedure as in the case of a new connection.
- 13.8. JMRC shall have the right to recover the fixed charges due as per applicable tariff for the remaining contracted period in case the contract is terminated prior to the expiry of the contracted period.
- 13.9. If there is any harm/loss to the property of JMRC or to any other third party due to fault in the electrical work, outlets or apparatus within the premises of the applicant, all the loss shall be borne by the Applicant.
- 13.10. The Total Demand Load& Total Connected load shall be treated as same. Applicant will have to pay applicable demand charges as per the Total Connected Load Only.
- 13.11. Applicant shall use Energy efficient lighting & shall provide proper Lighting fixtures, Lamps, Electronic Ballast etc. Applicant shall provide uniform & good



illumination level.

- 13.12. Applicant shall provide proper Earthing connection as per the applicable standards and shall terminate the same to the JMRC's Distribution Board or to any other place as directed by the JMRC. Installation Test Report issued by licensed electrical wiring contractor in the prescribed format (available with the application form) and countersigned by the applicant shall be submitted by the Applicant. Every shop/ property Development area must have enough Fire Extinguishers as stipulated.
- 13.13. Applicant will not be allowed to provide Room Heating appliance of any kind in the Licensed/ licensed area.
- 13.14. In case, the Applicant is found misusing Electricity or tampering with the Energy meter, a token penalty of Rs. 1000/- will be charged from him along with disconnection of power supply. Reconnection of power supply will be done only after charging Rs. 2000/- as reconnection fee and clearance of all dues duly obtaining approval of Competent Authority of JMRC.
- 13.15. The applicant shall not cause a demand more than sanctioned load. In case he causes a demand more than sanctioned load in a particular month, apart from being disconnected, he shall be required to pay an extra charge equal to the same percentage of the fixed and energy charges by which percentage the excess demand has actually been caused. In case, the power requirement in addition to the sanctioned load is felt by Licensee, the same shall be applied to GM (Tr./E&M). On payment of demand charges and sanction of additional load only, the Licensee shall be entitled to use additional load.
- 13.16. The Applicant shall have no objection at any time to the rights of JMRC to supply energy to any other consumer from the service line or apparatus installed by JMRC inside/ adjacent to applicant's premises.
- 13.17. The supply shall be used for the purpose that it has been sanctioned by JMRC and shall not be misused in any way to serve any other purposes.
- 13.18. The power supply shall not be extended/ sublet to any other licensee/ user.
- 13.19. JMRC shall be at liberty to adjust the electricity consumption charges along with any other charges against the consumption deposit paid by the Applicant, in the event of termination of the agreement prior to the expiry of the contracted period or in case of any contractual default.
- 13.20. JMRC shall be at liberty to transfer the dues remaining unpaid by the Applicant, after adjusting the advance electrical security deposit, to other service connections(s) that may stand in the Applicant's name.
- 13.21. The applicant shall allow clear and unencumbered access to the meters for the purpose of meter reading, maintenance, inspection, checking, testing etc. in case the same is installed inside the Licensed/ licensed premises.
- 13.22. JMRC shall be entitled to disconnect the service connection under reference in the event of any default and /or non-compliance of statutory requirements and/or in consequence of legally binding order by statutory authority (ies)/court of Law, without prejudice to the JMRC's rights to exercise its rights



under law including that of getting its due payments as on the date of connection. The Applicant undertakes to pay penalty imposed by JMRC on its own discretion for the damages caused to the Licensed property on account of any default or non-compliance of any statutory requirements.

- 13.23. The applicant acknowledges and accepts that the relationship of the applicant with JMRC is not that of a consumer and Service provider but that of a commercial arrangement where the applicant has taken on License/license premises of JMRC and the Electricity connection is being provided as a part of the above arrangement.
- 13.24. Licensee shall ensure that all electrical wiring, power outlets and gadgets are used and maintained properly, for guarding against short circuits / fires. The instructions in this regard by the JMRC Electrical Inspector/ authorized representative must be complied with. Any cost/s associated with implementation of such instruction shall be borne solely by the Applicant. The Applicant voluntarily and unequivocally agrees not to seek any claims, damages, compensation or any other consideration whatsoever on account of implementing the instruction issued by JMRC Fire Officer, Electrical Inspector, Security Officer or their authorized representative from time to time.
- 13.25. At the end of the contract (pre-mature surrender/termination, natural completion, etc.) all cable, pre/post-paid meter, connected software, etc. which are installed by JMRC, shall be sole property of JMRC. The Licensee shall leave the premises without any damage to JMRC's electrical installation after expiry of the contract.
- 13.26. The Licensee shall be at liberty on termination of his License/ contract to remove or take away such fixtures, fittings and electrical appliances installed by it, leaving the Licensed premises, as far as possible, in the same conditions structurally, reasonable wear and tear and acts of God and nature excepted.

**APPENDIX TO ANNEXURE-XI**

**Format of Application for Permanent/Temporary Power Supply**

**To,**

Executive Director (Traction/E&M)  
Jaipur Metro Rail Corporation

Dear Sir,

Kindly provide electricity connection for ..... purpose at ..... Jaipur Metro Rail Station, as per following details:-

<b>SN</b>	<b>Item</b>	<b>Details</b>
1.	Name of the Applicant	
2.	Station	
3.	Location	
4.	Reference to allotment letter (Copy to be attached)	
5.	Load Requirement (KW)	
6.	Details of submission of Electrical Security Deposited as per load demand	
7.	Details of submission of one time lump-sum amount as per load demand	
8.	Details of Cable installed/ to be installed along with earthing (Make, rating and specification)	
9.	Details of MCCB/MCB installed/ to be installed (make, rating and	

SN	Item	Details
	specification)	
10.	Details of ELCB installed/ to be installed (make, rating and specification)	
11.	Attach cable layout plan of Licensed space	
12.	Attach electrical installation test reports (L Form) signed from electrical contractor holding valid license/ qualified diploma/ degree Electrical Engineer. (In case of Permanent Connection)	

All details furnished in the application are true to the Applicant's knowledge. If any information is found incorrect at a later date, JMRC will have the right to withhold/disconnect supply, as the case may be, and forfeit the Electrical Security deposit. We further agree to abide by all the Rules & Guidelines of JMRC for reLicense, upkeep & maintenance of electrical power.

Signature of Applicant

**Encl:**

1. Copy of letter of acceptance.
2. Copy of Notice to proceed.

**Note:** After receiving application along with all relevant papers/submission of all required amount from Licensee, the Traction/ E&M Department of JMRC shall reLicense electrical connection after verification and inspection of site.

**ANNEXURE-XII (I)**

**INDICATIVE DRAWING OF METRO PILLAR**

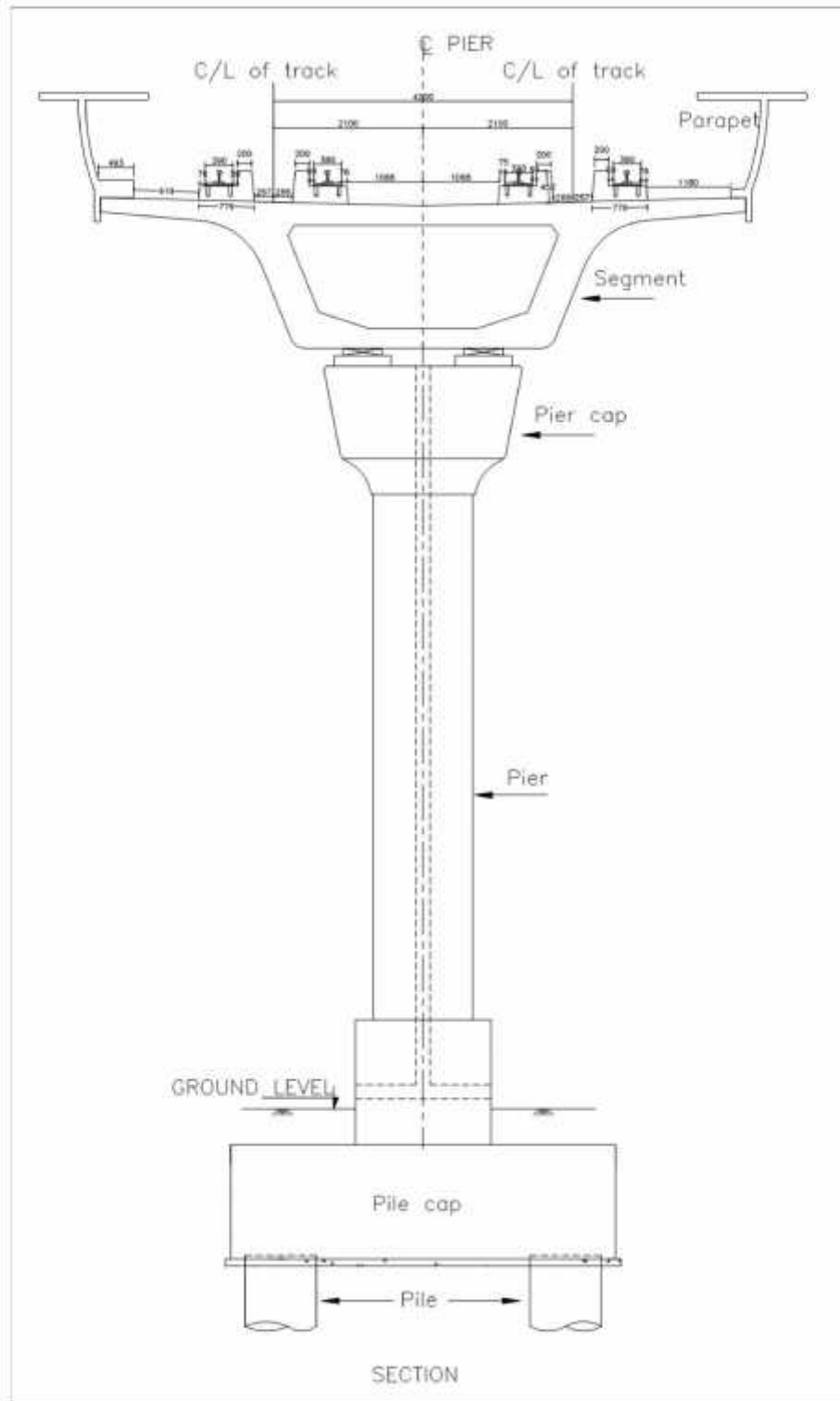

**ANNEXURE-XII (II)**

**INDICATIVE PHOTOGRAPHS OF METRO PILLARS WITH MICRO CELL EQUIPMENT**

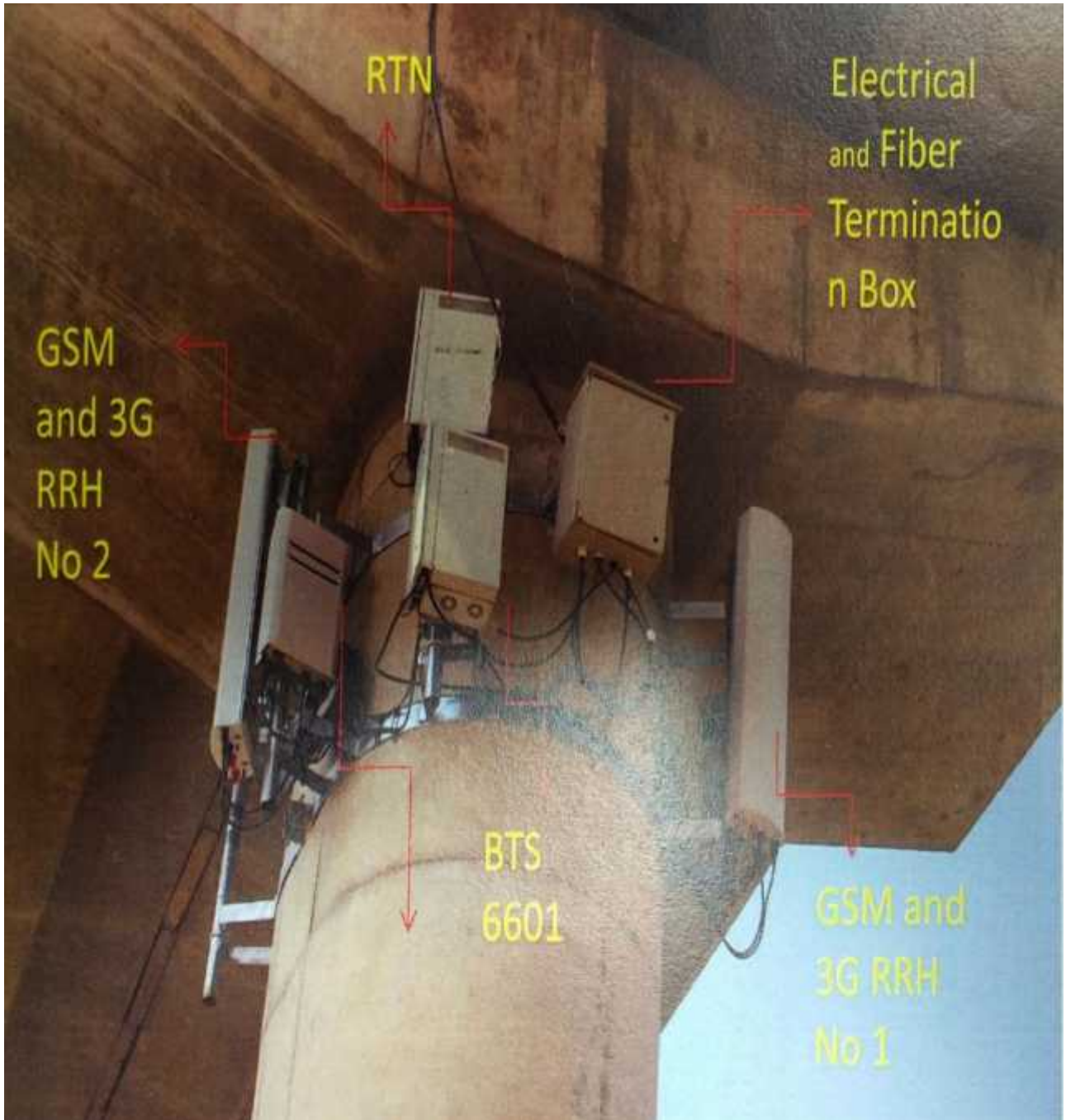

**ANNEXURE-XIII**

**FORMAT FOR INTIMATION FOR DEPOSITION OF PAYMENTS VIA RTGS/NEFT/ECS**

1. Name and address of Client/Licensee\_\_\_\_\_
2. Contract Name\_\_\_\_\_
3. Contract Detail/Number/Space/Package name\_\_\_\_\_
4. Invoice No. and Date\_\_\_\_\_
5. Period of Invoice\_\_\_\_\_
6. Head/item wise details of payment to be submitted as described in the invoice:

Item No.	Description/Head details	Period	Amount (in rupee)
1.	License Fee		
2.	Interest		
3.	Penalty		
4.	GST		
5.	Any other		
Gross amount			
Less statutory deductions such as TDS, Service Tax etc.			
Net amount deposited			
<b>Payment Details : (NEFT/ RTGS/ ECS)</b>			
Licensee's Bank name & IFSC Code			
Transaction ID/Reference ID			
Date & Time of transfer			
JMRC's Bank name, Branch & IFSC Code			

7. GST Registration No. of Licensee \_\_\_\_\_

Signature, Name and designation of  
authorized representative of Licensee.

---

**TO BE FILLED BY JMRC**

The Licensee has sent above details for License Fee Paid. This is for reconciliation at your end. Any discrepancy may be intimated pLicense.

**Signature**  
(Representative of Non-Fare Revenue Department/JMRC)

**Sr. EO (Accounts), Jaipur Metro Rail Corporation Limited (JMRC)**