

Bid Price: Rs. 1180/-

JMRC/O&S/RS/2023-24/NIB/026

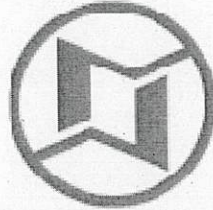

JAIPUR METRO

JAIPUR METRO RAIL CORPORATION LTD.

Directorate of Operations & Systems
Mansarovar metro train depot,
Bhrigu Path, Mansarovar Jaipur – 302020
Website: <http://transport.rajasthan.gov.in/jmrc>
Email: dos@jaipurmetrorail.in

PROCUREMENT OF SALOON DOOR ROLLERS COMPLETE

BID DOCUMENT

12/8/24

Check sheet for document submission by Bidders with Bid Document

S. No.	Documents	Enclosed Yes/No	Remarks
(A)	To be deposited Physically at JMRC up to last date of submission of bid (In Original)		
i.	DD/proof of fee deposition for Bid cost in favour of Jaipur Metro Rail Corporation Ltd, Jaipur		
ii.	Financial Instrument or Processing Fee payable in favor of MD, RISL, Jaipur		
iii.	Financial Instrument or EMD/Bid security amount in favour of Jaipur Metro Rail Corporation Ltd, Jaipur		
(B)	Through Online Mode on Eproc.rajasthan.gov.in (Signed & Scan copy)		
iv.	Complete, filled Bid document with seal and signed with any addendum/corrigendum/minutes of pre-bid meeting if issued.		
v.	Copy of GST Certificate & PAN Certificate with Seal and signed		
vi.	<u>Financial Standing (Annual Turnover):</u> Copy of annual turnover proof of applicant during last three audited financial years. To substantiate the Annual Turnover, Contractor needs to submit the Chartered Accountant (CA) Certificate.		
vii.	Cancelled Cheque for future payment reference(optional)		
viii.	Firm shall submit the copy of at least one year of satisfactory performance certificate of door rollers supply.		
ix.	Proof of board resolution/power of attorney, in vogue for signing of bid document (Refer form 'F' of bid)		
x.	Relevant forms mentioned in clause 6 to be filled and signed		
xi.	Any other document if bidder wants to submit.		

NOTE:

a. PRICES SHALL BE INDICATED ONLY IN THE FINANCIAL BID. Price bid should NOT be indicated at any place in the Technical Bid, otherwise the Proposal shall be summarily rejected.

b. The Financial Bid shall be submitted online through the prescribed website as per the instructions on the webpage therein. The prices shall be submitted online in the Financial Bid.

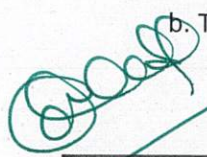

Signature of Authorized Signatory of Bid

TABLE OF CONTENTS

1. NOTICE INVITING BID(NIB)	4
2. INSTRUCTIONS TO BIDDER	7
2.1 GENERAL	7
2.2 BID DOCUMENTS	7
2.3 SUBMISSION OF BIDS	7
2.4 DOCUMENTS COMPRISING THE BID	8
2.5 EVALUATION OF BID	12
2.6 NEGOTIATION	12
2.7 AWARD OF CONTRACT & PERFORMANCE SECURITY DEPOSIT	13
2.8 Additional Performance Security:-	14
2.9 SIGNING OF AGREEMENT	14
2.10 GENERAL CONDITIONS OF CONTRACT	15
3 SPECIAL TERMS AND CONDITIONS OF BID & CONTRACT.....	16
3.1 Bidders to Bid for all Items	16
3.2 Variation	16
4 SCOPE OF WORK:.....	16
4.1 Terms & Conditions	16
5 Technical Specifications	19
6 FORMATS FORMING PART OF TECHNICAL BID	21
6.1 Form: A- DECLARATION	22
6.2 Form: B FORM OF BID	23
6.3 Form: C Format of Bank Guarantee for Performance Security	25
6.4 FORM D FORM OF BANK GUARANTEE FOR BID SECURITY	27
6.5 Form: E AGREEMENT	29
6.6 Form: F Power of Attorney for Signing of Bid	31
6.7 Form: G Form of Self Declaration	32
6.8 Form: H Compliance with the Code of Integrity and No Conflict of Interest	33
6.9 Form: I GENERAL INFORMATION	34
6.10 Form: J BANK DETAILS FOR E-PAYMENT	36
6.11 Form: K GRIEVANCE REDRESSAL DURING PROCUREMENT PROCESS	37
7 Financial Bid:	40



Signature of Authorized Signatory of Bid

1. NOTICE INVITING BID(NIB)

Jaipur Metro Rail Corporation (JMRC) Ltd. Invites online **open e-bids (Single- stage Two cover method)** bidding process for "PROCUREMENT OF SALOON DOOR ROLLERS COMPLETE"

KEY DETAILS:

a)	Designation and address of inviting authority	Director(O&S),JMRC JAIPUR
b)	UBN No.	
c)	NIB/Bid No	JMRC/O&S/RS/2023-24/NIB/026
d)	Name of Work	"Procurement of Saloon Door Rollers Complete"
e)	Approximate Estimated Cost of Work	Rs. 70,67,161.60/- (Including 18% GST)
f)	Cost of Bid Document (Non-Refundable)	Rs. 1180/- including 18% GST, By cash or by bank demand draft/banker's cheque in favour of Jaipur Metro Rail Corporation Ltd., Jaipur.
g)	Processing Fee	Rs.1500/- by Demand Draft / Bankers Cheque in favour of MD, RISL, Jaipur payable at Jaipur.
h)	Earnest Money Deposit (EMD) / Bid Security.	Bid Security shall be 2% (Rs. 1,41,344/-) of the estimated value by bank demand draft/banker's cheque/Bank Guarantee in favour of Jaipur Metro Rail Corporation Ltd., Jaipur. (Refer Clause 2.3).
i)	Performance security	(5% of LOA/PO Amount) in the form of Banker's Cheque/ Demand Draft/ Bank guarantee/FDR of a Scheduled Bank in favour of "Jaipur Metro Rail Corporation Ltd." payable at Jaipur. (REFER CLAUSE 2.7)
j)	Online Bid Document Availability Period	From 17:00 hrs of 27.08.2024 to 13:00 hrs of 27.09.2024
k)	Date and Place of Pre Bid Conference	On 05.09.2024 at 11:00 hrs. Conference Room-D10, Mansarovar Metro Train Depot, Workshop Building, Bhriugu path, Mansarovar Jaipur - 302020 Email: gmrs@jaipurmetrorail.in jgmrs@jaipurmetrorail.in
l)	Websites for downloading Bid Document and subsequent clarification/ modification, if any	http://transport.rajasthan.gov.in/jmrc www.sppp.rajasthan.gov.in https://eproc.rajasthan.gov.in
m)	Last date for receiving queries/clarifications BY Email/Post/hand	Up to 05.09.2024 at 17:00 hrs.
n)	Up loading of Remarks of Metro Administration to the Issues raised by Bidders by Email/Post	Up to 09.09.2024 at 17:00 hrs.
o)	On line submission start date & time	On 10.09.2024 at 09:00 hrs.
p)	Last Date & Time of online submission of Bid	On 27.09.2024 at 15:00 hrs.
q)	Venue and Last Date of Physical Submission of Bid Cost, Bid Security and Processing Fee.	On 27.09.2024 at 15:00 hrs. Room no. S09, DCOS Building, Metro Train Depot, Mansarovar, Jaipur -302020, Contact no. 7728895716

Signature of Authorized Signatory of Bid

r)	Time & Date of Opening of Online Technical Bid	On <u>27.09.2024</u> at <u>15:30</u> hrs.
s)	Date, time and Venue for opening of Financial Bid of Technically qualified bidders.	Date, time and Venue of Financial Bid opening will be intimated to the Technically qualified bidders through letter/e-mail/phone
t)	Validity of Bid	90 days from the last date of submission of Bid.
u)	Delivery of items	08 Months or earlier from the date of issue of "Purchase Order".
v)	Eligibility Conditions	<p>a) Bidder should have valid GST registration certificate issued by competent authority and shall enclose GST certificate along with bid submission.</p> <p>b) Applicant should have valid PAN certificate/ card issued by the Income Tax Dept. of GOI and enclose PAN certificate.</p> <p>c) The supplier shall have successfully supplied the Saloon Door Rollers to any Metro/Railway in last 03 years. (Similar work means "Supply of Door Rollers to Indian Metros/Indian Railway")</p> <p>d) <u>Financial Standing (Annual Turnover)</u>: The average annual turnover of applicant during last three audited financial years should not be less than 40% of estimated cost. To substantiate the Annual Turnover, Contractor needs to submit the Chartered Accountant (CA) Certificate.</p> <p>e) Firm shall not be blacklisted by Central Government, any State Government or any Government agency or Public sector undertaking (PSU). Firm shall submit an undertaking to this effect as per Form A.</p>
w)	Bank Account details should be attached with bid document by bidder on their letter-head duly signed and stamped or should be supported with one copy of cancelled cheque. (Form J: Bank details)	
x)	The complete bid document can be downloaded from the state e-procurement Website https://www.eproc.rajasthan.gov.in and interested bidders will have to submit their offer in electronic formats both for technical and financial proposal on this website with their digital signatures. The complete bid document can also be seen on Corporation's website http://transport.rajasthan.gov.in/jmrcand state procurement portal i.e., www.sppp.raj.nic.in	
	Bidders who wish to participate in this bidding process must register on https://eproc.rajasthan.gov.in . To participate in online bids, as per Information Technology Act, 2000, Bidders will have to obtain Digital signature Certificate (DSC) from any agency approved by Controller of Certifying Authorities (CCA). Bidders who already have a Valid Digital Signature Certificate need not to obtain a new Digital Signature Certificate. This DSC will be used to sign the bids submitted online by the bidder. Unsigned bids will not be entertained and will be rejected outright	
At any stage if it is found that bidder has not met any of the above eligibility criteria, his bid will be summarily rejected and action shall be taken as per terms and conditions of this bid documents.		

Note:

1. All bidders or their authorized representative may attend the opening of Bid.
2. Corrigendum, Addendums and subsequent clarifications on bid terms, if any, can be downloaded from the above mentioned websites. Intimation for change in the schedule of Bid

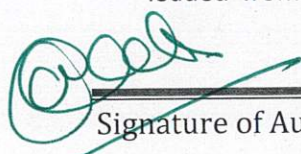

Signature of Authorized Signatory of Bid

opening etc. shall be published on above mentioned websites only. Keep visiting these websites for any subsequent clarifications & modifications.

3. If same firm/company quoted bid more than one at different branches for bidding process, all such that bid will be rejected as per Rule 81 of RTPPR, 2013.
4. In case of any further details/clarification required, the same can be collected/clarified from the office of General Manager(RS)

Office of GM (Rolling Stock),
Room no. D-01, Workshop Building,
Mansarovar metro train depot, Bhriugu path, Mansarovar, Jaipur-302020
Email: gms@jaipurmetrorail.in
Cont. No. +91- 9650093279

NOTE: - Approved GCC is uploaded and available on the JMRC website, By Signing the Bid document, firm agrees to accept the GCC.

The Contract is governed by latest RTPPR Rule, 2013. Bid has been prepared and submitted in accordance with the instructions given herein.



2. INSTRUCTIONS TO BIDDER

2.1 GENERAL

Online Bid is invited for the Bid No. JMRC/O&S/RS/2023-24/NIB/026 towards "PROCUREMENT OF SALOON DOOR ROLLERS COMPLETE" by Jaipur Metro Rail Corporation Limited hereinafter called the 'Employer', for Goods/Services/Works in accordance with this Bid Package. The Bid consist of the following documents, along with their Tables, appendices, addenda, corrigenda and errata if any.

- (i) Notice Inviting Bid
- (ii) Instructions To Bidder (ITB)
- (iii) Special Conditions of Contract (SCC) and Scope of Work
- (iv) Technical Specifications
- (v) Formats forming part of technical bid
- (vi) Financial Bid - Bill of Quantities(BOQ)

"The Rajasthan Transparency in Public Procurement Act, 2012 and the "The Rajasthan Transparency Public Procurement Rules, 2013" under the said Act have come into force which are available on the website of State Public Procurement Portal <https://sppp.rajasthan.gov.in>. The Bidders are advised to acquaint themselves with the provisions of the Act and the Rules before participating in the Bidding process. If there is any discrepancy between the provisions of the Act and the Rules and this Bidding Document, the provisions of the Act and the Rules shall prevail.

2.2 BID DOCUMENTS

CONTENTS OF BID DOCUMENTS

The Bidder is expected to examine carefully all the contents of the Bid documents including instructions, conditions, forms, terms, specifications and take them fully into account before submitting his offer. Failure to comply with the requirements as detailed in these documents shall be at the Bidder's own risk. Bids, which are not responsive to the requirements of the Bid documents, will be rejected.

2.3 SUBMISSION OF BIDS

COST OF BID DOCUMENT AND BID SECURITY /EMD

- 2.3.1 The BID should be submitted in the prescribed Bid document, which may be purchased, cost of bid document as specified in NIB by Cash or DD/Banker Cheque drawn in favour of Jaipur Metro Rail Corporation Ltd., payable at Jaipur. The complete bid document can also be downloaded from the website <http://transport.rajasthan.gov.in/jmrcor> or www.sppp.rajasthan.gov.in or www.eproc.rajasthan.gov.in. In case the bid document is downloaded from website, the cost of bid document is to be submitted in the form of DD/Banker's Cheque along with the Bid document submitted. The cost of the Bid document is non-refundable. Bidding document shall be provided to the MSME of Rajasthan at 50% of the prescribed cost.
- 2.3.2 Bid security can be deposited in the form of Demand Draft/ Bankers Cheque/Bank Guarantee of amount defined in NIB key details "clause-h" drawn in favour of Jaipur Metro Rail Corporation Ltd., payable at Jaipur, shall form part of the bid.
- 2.3.3 Bid security shall be 2% of the estimated value of subject matter of procurement. In case of Small Scale Industries of Rajasthan it shall be 0.5% of the quantity offered for supply and in case of sick industries other than Small Scale Industries, whose cases are pending with Board of Industrial and Financial Reconstruction; it shall be 1% of the value of bid. (Please refer rule 42 of RTPPR i.e. Rajasthan Transparency in Public Procurement Rules, 2013. Proof of such exemption has to be submitted with the bid document.

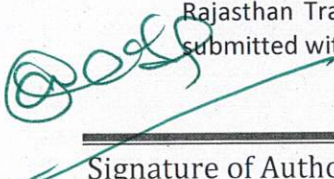
Signature of Authorized Signatory of Bid

2.3.4 Bid security, if submitted in the form of Bank Guarantee shall be executed on stamp paper of minimum 0.25% of value of B.G under Rajasthan stamp act.

Bank Details of JMRC are as below:

Account holder name: Jaipur Metro Rail Corporation

Account no. : 678605111973

IFSC code : ICIC0006786

2.3.5 The Bid Security of unsuccessful bidders shall be refunded soon after final acceptance of successful bid and submitting performance security.

2.3.6 The Bid Security taken from a bidder shall be forfeited, including the interest, if any, in the following cases, namely: -

- a) When the bidder withdraws or modifies its bid after opening of bids;
- b) When the Bidder fails to commence the supply of the goods or service or execute work as per supply/ work order within the time specified;
- c) When the Bidder does not deposit the performance security within specified period after the supply/ work order is placed; and
- d) If the Bidder breaches any provision of code of integrity, prescribed for bidders, specified in the bidding document.

2.3.7 Notice will be given to the Bidder with reasonable time before Bid Security (EMD) deposited is forfeited.

2.3.8 No interest shall be payable on the Bid Security (EMD).

2.3.9 In case of the successful Bidder, the amount of Bid Security may be adjusted in arriving at the amount of the Performance Security, or refunded if the successful Bidder furnishes the full amount of performance security.

2.3.10 The procuring entity shall promptly return the Bid Security of the successful Bidder after the earliest of the following events, namely:-

- a) The expiry of validity of Bid Security;
- b) Issue of LOA for procurement and performance security is furnished by the successful Bidder;
- c) The cancellation of the procurement process; or
- d) The withdrawal of bid prior to the deadline for presenting bids, unless the bidding documents stipulate that no such withdrawal is permitted.

2.4 DOCUMENTS COMPRISING THE BID

2.4.1 BID PACKAGE

An on line single- stage two cover selection procedure shall be adopted. The Bid is divided into two parts, viz. Technical Bid and Financial Bid:

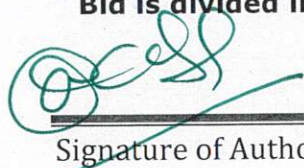

Signature of Authorized Signatory of Bid

2.4.1.1 **TECHNICAL BID (1st Cover)**: This Part should contain the Technical Bid consisting of a pdf copy of this Bid Document with each page digitally signed by the Bidder in acceptance of the terms and conditions therein, along with scanned copy of all the required documents, comprising the following:

1. Bid cost, Bid Security/EMD and processing fee

- a. These original Instruments should be submitted as per venue and date defined in NIB key details with forwarding letter mentioning the NIB No., Name of Work and particulars of these financial instruments.
- b. At the backside of every instrument, firm needs to mention Name of Firm, NIB No. and Mobile No. of authorized signatory of the firm.
- c. Scanned copy of Bid cost, Bid Security/EMD and Processing Fee Instruments need to be submitted with the online Bid and these original instruments are to be submitted as per schedule.
- d. If firm fails to submit the original instruments in the desired form and amount by the stipulated date and time then its Technical and Financial Bids shall not be opened and it shall be summarily rejected.
- e. If scanned copy of or all of these instruments (i.e. Cost of Bid Form, Processing Fee and Bid Security/EMD) Submitted with Technical Bid does not match with the original instruments submitted by the firm then Technical and Financial Bids Submitted by the firm shall be liable for rejection.

2. **Copy of the Bid Document** - The bidder shall enclose digitally signed and stamped, (lead member in case of Consortium) copy of the Bid Document except the Financial Bid (BOQ). Bids, digitally signed without any of the information desired in the prescribed formats will not be considered. Besides this all other associated / required documents shall be submitted duly numbered and digitally signed/ stamped by the bidders.

Documents as listed below:

- (i.) Notice Inviting Bid
- (ii.) Instructions To Bidder (ITB)
- (iii.) Special Conditions of Contract (SCC) and Scope of Work
- (iv.) Technical Specifications
- (v.) Formats forming part of technical bid

All such Annexure should be duly filled, signed & scanned (in pdf format) and digitally signed on each page and to be submitted online as part of technical bid.

**NOTE: PRICES SHALL BE INDICATED ONLY IN THE FINANCIAL BID (2nd cover).
Price bid should NOT be indicated at any place in the Technical Bid, otherwise
the Proposal shall be summarily rejected.**

1. **FINANCIAL BID (2nd cover) – BILL OF QUANTITIES (BOQ) in XLS Format**

The Financial Bid shall be submitted online through the prescribed website as per the

Signature of Authorized Signatory of Bid

instructions on the webpage therein. The prices shall be submitted online in the Financial Bid Format as per Sample Format of Financial Bid (BILL OF QUANTITIES) of Bid enclosed.

These prices should include all costs associated with the contract.

2. Utmost care is taken to upload Financial Bid. Any change in the format of Financial Bid file shall render it unfit for bidding. Following Steps may be followed in submission of Financial Bid:
 - a. Download format of financial bid in XLS format (Password protected file).
 - b. This XLS file is password protected file. Don't unprotect the file. Price has to be filled in this file and the same has to be uploaded.
 - c. Fill Bidder Name, Item rate (Less/ Excess) to the estimated cost in down loaded Financial Bid format as specified (in XLS format only) in green back ground cells. Don't fill in any other back ground cells.
3. Save filled copy of downloaded financial bid file in your computer and remember its name & location for uploading correct file (duly filled in) when required.
 - a. Documents to be submitted by the bidder under bid package have been described under the respective Clause. This list of documents has been prepared mainly for the convenience of the bidder and any omission on the part of the Employer shall not absolve the bidder of his responsibility of going through the various clauses in the bid Documents including the specifications and to submit all the details specifically called for (or implied) in those clauses.

2.4.2 SUBMISSION OF PROPOSAL

2.4.2.1 PREPARATION FOR ONLINE SUBMISSION:

1. Online bids will have to be digitally signed and submitted in time on the website <http://eproc.rajasthan.gov.in>.
2. To participate in online bidding process, bidders must procure a Digital Signature Certificate as per Information Technology Act-2000 using which they can digitally sign their electronic bids. Bidders can procure the same from any CCA approved certifying agency, i.e. TCS, safe crypt, N code, etc. Bidders who already have a valid Digital Signature Certificate (DSC) need not procure a new DSC.
3. The bidder should get him registered on procurement portal (<https://eproc.rajasthan.gov.in>) and create users and assign roles on this portal. Further to this, bidder shall download Notice Inviting Bids (NIB) and copy of Bid Document from this site.
4. Deadline for Submission of Bids: - Bids shall be received online on website <http://eproc.rajasthan.gov.in> with uploading of all relevant documents not later than the time and date communicated by the department or extended date thereof.
5. The bids will be submitted online only at web site <http://eproc.rajasthan.gov.in>. In no case bid will be submitted physically.

Signature of Authorized Signatory of Bid

2.4.2.2 ON LINE SUBMISSION:-

1. Bidder shall submit their bid in electronic format digitally signing the same. Bidder (authorized signatory) shall submit their offer on-line in Electronic formats both for Technical and financial Bid. The Technical Bid should also contain scanned copy of Financial Instruments (Cost of Bid Form, E-bid Processing Fee and Bid Security Amount. However, the original financial instrument for Cost of Bid Form, E-bid Processing Fee and Bid Security/EMD should be submitted in a sealed envelope physically/by post at the following address of JMRC by the scheduled date and time as per NIB.
**Office of Manager, Rolling Stock – Room no. 509,
DCOS Building, Metro Train Depot,
Mansarovar, Jaipur – 302020
Email id: mgrs2@jaipurmetrorail.com
Contact No.:- 7728895705**
2. All pages of the bid document and the addendums/amendments uploaded by the JMRC on the website <http://eproc.rajasthan.gov.in> shall be deemed to have been initialed and accepted by the persons signing the bid when they submit their electronic bid.
3. The documents listed in ITB along with the addenda uploaded till the date of bid submission, shall be filled by the bidder to bind the bidder to the contract. All the pages of the bid and documents shall be digitally signed.
4. The uploaded documents for technical-bid or bid fee or processing fee or any other document required for e-bidding cannot be changed after closing date of bid and same documents are to be produced in original physical form in the office whenever asked to do so.
5. Utmost care to be taken to name the files /documents to be uploaded on portal. There should not be any special character or space in the name of file, only underscores are permissible. All Bids in which any of the prescribed conditions are not fulfilled or which have been vitiated by errors in calculations, totaling or other discrepancies or which contain overwriting in figures or words or corrections not digitally initialed and dated, may be liable to rejection.
6. Bids sent telegraphically or through other means of transmission (Email, Tele-fax etc.), which cannot be delivered in a sealed envelope, shall be treated as defective, invalid and shall stand rejected.
7. The uploaded documents for e-bidding cannot be changed after closing date of bid and same documents are to be produced in original physical form in the office whenever asked to do so.

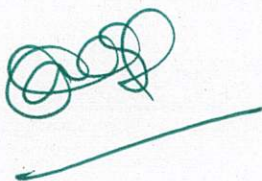

2.5 EVALUATION OF BID

2.5.1 The bid will be opened online on website at the time and date as per schedule specified in the Notice Inviting Bid in the presence of Bidder's or their authorized representative's who may choose to be present at the time of bid opening, if the bidder wishes. Participating bidders can view and access the outcome of technical bid online also.

2.5.2 The bids shall be opened in two part/cover. In first part/cover, the technical bid shall be opened and evaluated. In second part/cover, Financial Bid of all technically qualified bidders, who qualify the technical evaluation will be opened on the date and time intimated to all such bidders separately by email. Bidders are also advised to keep abreast of the website for announcement of the date.

2.5.3 Preliminary Examination of Bids

a. The contents of the documents of the individual bids will be examined summarily in order to assess their formal conformity and agreement with the instructions and guidance to the Bidders and the completeness as per eligibility criteria and technical responsiveness. Any bid not conforming to any of these requirements may be disqualified forthwith at the discretion of Jaipur Metro Rail Corporation.

b. The ranking of L1, L2, L3 etc, will be done on basis of least Cost for overall items of financial BOQ.

2.6 NEGOTIATION

2.6.1 Except in case of procurement by method of single source procurement or procurement by competitive negotiations, to the extent possible, no negotiations shall be conducted after the pre-bid stage. All clarifications needed to be sought shall be sought in the pre-bid stage itself

2.6.2 Negotiations may, however, be undertaken only with the lowest or most advantageous bidder under the following circumstances-

a) When ring prices have been quoted by the bidders for the subject matter of procurement;
or

b) When the rates quoted vary considerably and considered much higher than the prevailing market rates.

2.6.3 The bid evaluation committee shall have full powers to undertake negotiations. Detailed reasons and results of negotiations shall be recorded in the proceedings.

2.6.4 The lowest or most advantageous bidder shall be informed in writing either through messenger or by registered letter and email (if available). A minimum time of seven days shall be given for calling negotiations. In case of urgency the bid evaluation committee, after recording reasons, may reduce the time, provided the lowest or most advantageous bidder has received the intimation and consented to regarding holding of negotiations.

2.6.5 Negotiations shall not make the original offer made by the bidder inoperative. The bid evaluation committee shall have option to consider the original offer in case the bidder decides to increase rates originally quoted or imposes any new terms or conditions.

2.6.6 In case of non-satisfactory achievement of rates from lowest or most advantageous bidder, the bid evaluation committee may choose to make a written counter offer to the lowest or most advantageous bidder and if this is not accepted by him, the committee may decide to reject and re-invite bids or to make the same counter-offer first to the second lowest or most advantageous bidder, then to the third lowest or most advantageous bidder and soon in the

order of their initial standing and work / supply order be awarded to the bidder who accepts the counter-offer. This procedure should be used in exceptional cases only.

- 2.6.7 In case the rates even after the negotiations are considered very high, fresh bids shall be invited.

2.7 AWARD OF CONTRACT & PERFORMANCE SECURITY DEPOSIT

- 2.7.1 Prior to delivery of items and Performance security shall be solicited from successful Bidder except the departments of the State Government and undertakings, corporations, autonomous bodies, registered societies, co-operative societies which are owned or controlled or managed by the State Government and undertakings of the Central Government. However, a performance security declaration shall be taken from them. The State Government may relax the provision of performance security in particular procurement or any class of procurement.
- 2.7.2 The amount of performance security shall be 5% of the amount of supply order/ Purchase order/LOA in case of procurement of goods and services. In case of small scale industries of Rajasthan it shall be one percent of the amount of quantity ordered for supply of goods and in case of sick industries, other than Small Scale Industries, whose cases are pending before the Board of Industrial and Financial Reconstruction (BIFR), it shall be two percent of the amount of supply order.
- 2.7.3 Amount to be paid of performance security will be informed to successful bidder at the time of Purchase order/LOA.
- 2.7.4 Performance security shall be furnished in any one of the following forms: -
- Bank Draft or Banker's Cheque of a scheduled bank;
 - Bank guarantee/s of a scheduled bank. It shall be got verified from the issuing bank. Other conditions regarding bank guarantee shall be same as mentioned in the bidding document for Bid Security. If submitted in the form of Bank Guarantee shall be executed on stamp paper of minimum 0.25% of value of B.G under Rajasthan stamp act.
 - Fixed Deposit Receipt (FDR) of a scheduled bank. It shall be in the name of procuring entity on account of Bidder and discharged by the Bidder in advance. The procuring entity shall ensure before accepting the FDR that the Bidder furnishes an undertaking from the bank to make payment/ premature payment of the FDR on demand to the procuring entity without requirement of consent of the Bidder concerned. In the event of forfeiture of the performance security, the Fixed Deposit shall be forfeited along with interest earned on such Fixed Deposit.
- 2.7.5 Performance security shall be valid for a period of 60 days beyond the completion of all contractual obligations.
- 2.7.6 Performance security will have to be deposited within 30 days from the date of issue of Purchase order/LOA.
- 2.7.7 Performance Security amount in full or part may be forfeited, including interest, if any, in the following cases:-
- When any terms and condition of the contract is breached.

- b. When the Bidder fails to make complete supply satisfactorily.
- c. If the Bidder breaches any provision of code of integrity, prescribed for Bidders, specified in the bidding document.

2.7.8 Notice will be given to the Bidder with reasonable time before Performance Security deposited is forfeited.

2.7.9 No interest shall be payable on the Performance Security Deposit.

2.8 Additional Performance Security:-

- a. In addition to Performance Security as specified in rule 75, an Additional Performance Security shall also be taken from the successful bidder in case of unbalanced bid. The Additional Performance Security shall be equal to fifty percent of Unbalanced Bid Amount. The Additional Performance Security shall be deposited in lump sum by the successful bidder before execution of Agreement. The Additional Performance Security shall be deposited through e-Grass, Demand Draft, Banker's Cheque, Government Securities or Bank Guarantee.

Explanation: For the purpose of this rule,-

- i. Unbalanced Bid means any bid below more than fifteen percent of Estimated Bid Value.
 - ii. Estimated Bid Value means value of subject matter of procurement mention in bidding documents by the Procuring Entity.
 - iii. Unbalanced Bid Amount means positive difference of eighty five percent of Estimated Bid Value minus Bid Amount Quoted by the bidder.
- b. The Additional Performance Security shall be refunded to the contractor after satisfactory completion of the entire work. The Additional Performance Security shall be forfeited by the Procuring Entity when work is not completed within stipulated period by the contractor. Provision for 'Unbalanced Bid' and 'Additional Performance Security' shall be mentioned in the Bidding Documents by the Procuring Entity."
 - c. All other terms for additional performance security will be as per clause 2.7 of bid document.

2.9 SIGNING OF AGREEMENT

2.9.1 Successful bidder shall prepare the Agreement on non-judicial stamp as per stamp act, in the Performance, included in this Document, duly incorporating all the terms of agreement between the two parties. Within 30 days from the date of issue of the letter of acceptance/PO, the successful bidder will be required to execute the Contract Agreement. One copy of the Agreement duly signed by the Employer and the contractor through their authorized signatories will be supplied by the Employer to the Contractor.

2.9.2 Stamp duty for agreement will be born by Successful bidder.

2.9.3 Prior to signing of the Contract Agreement, the successful bidder shall submit the following documents within a period of 30 days from the date of issue of the Letter of Acceptance/PO:

- a. Performance Security.
- b. Detailed Consortium or Joint Venture Agreement (duly signed and executed)
Incorporating (if applicable):
 - i. Percentage Participation of each member/partner.
 - ii. Joint and several liability of the partners



Signature of Authorized Signatory of Bid

2.10 GENERAL CONDITIONS OF CONTRACT

2.10.1 Contract Documents:

Subject to the order of precedence set forth in the Agreement, all documents forming the Contract (and all parts thereof) are intended to be correlative, complementary, and mutually explanatory.

2.10.2 Scope of Supply

Subject to the provisions in the bidding document and contract, the execution of complete scope of work shall be executed as specified in the purchase order/LOA which will be issued by JMRC to the successful bidder.

2.10.3 Termination

1. Termination for Default

The Bid sanctioning authority of JMRC may, without prejudice to any other remedy for breach of contract, by a written notice of default of at least 30 days sent to the supplier/ Contractor, terminate the contract in whole or in part: -

- a. If the supplier/ Contractor fails to deliver any or all quantities of the service within the time period specified in the contract, or any extension thereof granted by JMRC; or
- b. If the supplier/ Contractor fails to perform any other obligation under the contract within the specified period of delivery of service or any extension granted thereof; or
- c. If the supplier/ Contractor, in the judgment of the Purchaser, is found to be engaged in corrupt, fraudulent, collusive, or coercive practices in competing for or in executing the contract.
- d. If the supplier/ Contractor commits breach of any condition of the contract.

2. If JMRC terminates the contract in whole or in part, amount of Performance Security Deposit may be forfeited.

3. Before cancelling a contract and taking further action, advice of senior most finance person available in the office and of legal adviser or legal assistant posted in the office, if there is one, may be obtained.

Note: In addition to the conditions specified above, the approved GCC are applicable and available on the JMRC website. The successful bidder shall submit a declaration for acceptance of the terms and conditions mentioned the GCC.

2.10.4 Transportation:

The rate quoted in BOQ shall include the cost of transport of item including all incidental arrangements for safe transport of items.

2.10.5 Price Fall Clause:

- i. The prices under a rate contract shall be subject to price fall clause. A clause regarding price fall shall be incorporated in the terms and conditions of rate contract. Price fall clause is a price safety mechanism in rate contracts and it provides that if the rate contract holder quotes / reduces its price to render similar goods, works or services at a price lower than the rate contract price to anyone in the State at anytime during the currency of the rate contract,

the rate contract price shall be automatically reduced with effect from the date of reducing or quoting lower price, for all delivery of the subject matter of procurement under that rate contract and the rate contract shall be amended accordingly.

- ii. The firms holding parallel rate contracts shall also be given opportunity to reduce their price by notifying them the reduced price giving those fifteen days time to intimate their acceptance to the revised price. Similarly, if a parallel rate contract holding firm reduces its price during currency of the rate contract, its reduced price shall be conveyed to other parallel rate contract holding firms and the original rate contract holding firm for corresponding reduction in their prices. If any rate contract holding firm does not agree to the reduced price, further transaction with it, shall not be conducted.

3 SPECIAL TERMS AND CONDITIONS OF BID & CONTRACT

3.1 Bidders to Bid for all Items

Bidder must quote for all the items mentioned in the BOQ (Bill of Quantities), in case, a Bidder does not quote for any item, the bid shall be summarily rejected.

3.2 Variation

- 3.2.1 Procuring entity has the right to vary the quantity/period as per RTPPR-2013
- 3.2.2 If the procuring entity does not procure any subject matter of procurement or procures less than the quantity specified in the bidding documents due to change in circumstances, the bidder shall not be entitled for any claim or compensation except otherwise provided in the bidding documents.
- 3.2.3 Repeat orders for extra items or additional quantities may be placed, on the rates and conditions given in the contract. Delivery or completion period may also be proportionately increased. The limits of repeat order shall be as under-
 - (a) 50% of the quantity of the individual items and 50% of the value of original contract in case of works; and
 - (b) 50% of the value of goods or services of the original contract.

4 SCOPE OF WORK:

4.1 Terms & Conditions

4.1.1 Scope of Supply

Subject to the provisions in the bidding document and contract, the goods and related services to be supplied shall be as specified in the purchase order.

4.1.2 Delivery

- a. Subject to the conditions of the contract, materials should be delivered within days as specified in NIB from the Date of P.O or earlier.

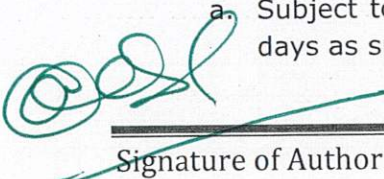
Signature of Authorized Signatory of Bid

- b. If national holiday is being declared on bid due date then bid will be opened on next suitable working day.
- c. The above material shall be delivered at JMRC Custody Store section, Room no. D20, Workshop building, Train maintenance Depot, Mansarovar -Jaipur-302020.
- d. The Contractor shall arrange supplies within the stipulated time period.

4.1.3 Inspection

- a. The Purchase Officer or his duly authorized representative shall inspect the material. During inspection, material/Items should be compatible with system of RS08 metro train of JMRC.
- b. Technical suitability of other than OEM or equivalent make will be given after successfully completion of performance check of 03 months operation of rollers on saloon door in RS 08 Trains.

4.1.4 Rejection

- a. Materials not approved during inspection or testing shall be rejected and will have to be replaced by the Contractor at his own cost within the time fixed by the Purchase Officer.
- b. If, however, due to exigencies of work, such replacement either in whole or in part, is not considered feasible, the Purchase Officer after giving an opportunity to the Contractor of being heard shall for reasons to be recorded, deduct a suitable amount from the approved rates. The deduction so made shall be final.
- c. The rejected articles shall be removed by the supplier/ Bidder/ Contractor within 15 days of intimation of rejection, after which Purchase Officer shall not be responsible for any loss, shortage or damage and shall have the right to dispose of such articles as he thinks fit, at the Contractor's risk and on his account.

4.1.5 Penalty

- a. If material not supplied within contract period as mentioned in NIB, then contractor shall be held responsible for liquidated damages. The liquidated damages is compensation of loss on account of late delivery (actually incurred as well as notional) where loss is pre-estimated and mutually agreed to procuring entity may recover from the contractor, as agreed, the liquidated damages a sum equivalent to 0.5 (one half) percent of the prices of any portion of stores delivered late, for each week or part thereof of delay. The total damages shall not exceed 10(Ten) percent of the value of delayed goods. However decision of procuring entity shall be final in this regard. The offer shall be unconditional and duly signed. Delivery period may be extended with or without penalty if approved by competent authority on request of contractor.

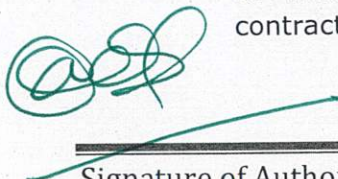

4.1.6 Warranty:

- a. Warranty to repair or replace free of cost such material which may develop defect due to defective material/workmanship within 18 months from the supply of material or 12 months from the installation in train whichever is earlier.

4.1.7 Payment Terms and Schedule

- a. Payment schedule: - Payment against item of P.O. would be made to the Contractor, after receipt and acceptance of material on part payment/delivery basis.
- b. Part payment will be made after receipt and acceptance of material against item wise quantity supplied of material against Purchase order.
- c. The currency or currencies in which payments shall be made to the supplier/ Contractor under this Contract shall be Indian Rupees (INR) only.
- d. All remittance charges will be borne by the supplier/ Contractor.
- e. Bills, correct in all respect, shall be submitted in the favour of JMRC, Jaipur with bank details in duplicate along with the acceptance certificate and relevant documents, if any, for arranging payment.

4.1.8 Other Special Terms

- i. The rates quoted of items shall be for final receipt of material at JMRC custody store, JMRC office, Mansarovar Metro Depot, Jaipur-302020 inclusive of all expenses i.e. all taxes (excluding GST), and Freight charges, transportation/freight charges, packing & forwarding charges, insurance and all other statutory duties etc; no other charges shall be paid by JMRC.
- ii. Consignee: JE/RS/Custody Store, Mansarovar Train maintenance Depot, Jaipur-Rajasthan.
- iii. JMRC's General conditions of contract shall be applicable.
- iv. In case the Bidder fails to supply the final deliverables within stated timelines, the Penalty as per clause "Penalty" would be applicable.
- v. In case of any errors/ inaccuracies remain in supply and services even after the final approval of design from the purchaser then the Contractor has to take corrective actions on Bidders part (including all related expenditure on any such measures). In such cases, due to delay in delivery schedule, the Penalty as per clause "Penalty" would be applicable.



Signature of Authorized Signatory of Bid

5 Technical Specifications

(A) Technical specifications

- i) All items must be compatible with the JMRC RS-08 metro Trains Saloon Door system.

S. No	Item Details	Quantity	Make
1.	<p>(i) Roller Complete Centric (KB Part no: 3T410101R07) or equivalent, Qty-640 (in no's) Material: Polyoxymethylene. Hardness : Shore D 82 Bearing Model : 6003DU, Bearing Mask : NSK</p> <p>Secure screw with Loctite 2701 Temperature range from +10 degree C to +60 degree C Max. Humidity 96% Radial load carrying capacity approx. 750N Axial load carrying capacity approx. 500N Resistance to detergent of wash plant Possible low swelling behaviour under above listed conditions</p>	640	M/s KBI or Equivalent
2.	<p>(ii) Roller Complete Eccentric (KB Part no: 3T410101R08) or equivalent, Qty-640 (in no's) Material: Polyoxymethylene. Hardness : Shore D 82 Bearing Model : 6003DU, Bearing Mask : NSK</p> <p>Secure screw with Loctite 2701 Temperature range from +10 degree C to +60 degree C Max. Humidity 96% Radial load carrying capacity approx. 750N Axial load carrying capacity approx. 500N Resistance to detergent of wash plant Possible low swelling behaviour under above listed conditions</p>	640	

Note: Drawing of Roller Complete Centric and Eccentric is attached at Annexure "A" below.

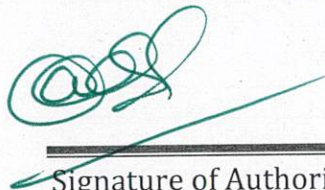

Signature of Authorized Signatory of Bid

Annexure "A"

a. Centric Roller

(All dimensions in mm)

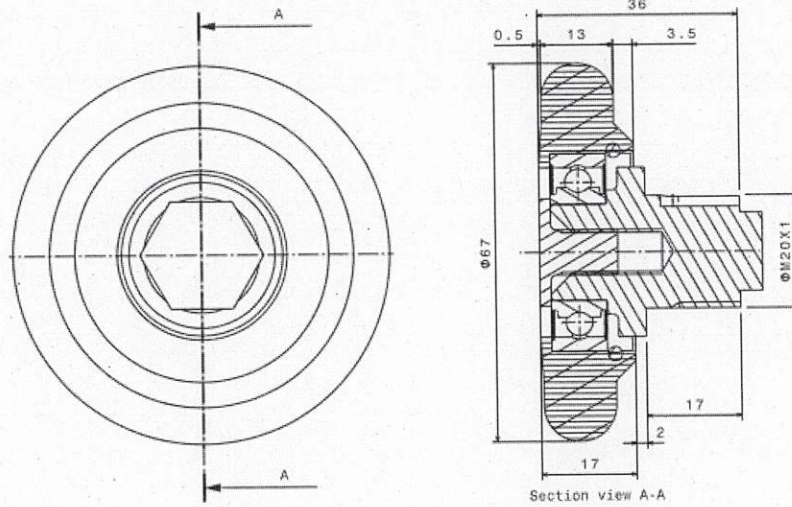

b. Eccentric Roller

(All dimensions in mm)

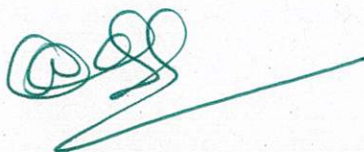
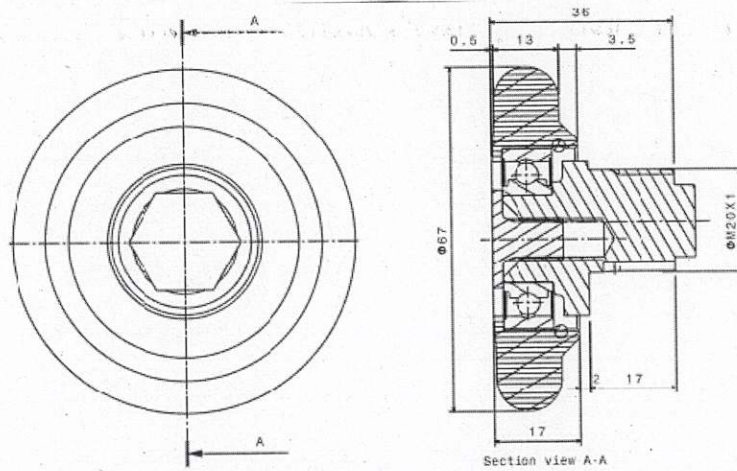

(B) Testing & Suitability

- i) Items should be compatible with the system of RS-08 Metro Trains of JMRC.
- ii) Material will be fitted in the train and suitability of other than OEM or equivalent make will be given after 03 months of successful operation of door rollers.
- iii) Test certificate for material hardness and load carrying capacity.

6 FORMATS FORMING PART OF TECHNICAL BID

INDEX	FORM
Declaration	A
Form of Bid	B
Format of Bank Guarantee for Performance Security	C
Form of Bank Guarantee for Bid Security	D
Form of Agreement	E
Form of Power of Attorney	F
Form of Self declaration	G
Form of Code of Integrity	H
General Information	I
Bank Details for E- Payment	J
Grievance Redressal During Procurement Process	K

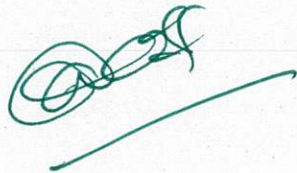

6.1 Form: A- DECLARATION

FORMAT FOR DECLARATION TO BE SUBMITTED BY BIDDER ALONG WITH THE BID DOCUMENT

I (Name and designation)** Appointed as attorney/authorized signatory of the Bidder (including its constituents), M/s (hereinafter called the Bidder) for the purpose of the Bid documents for the work of as per the Bid No..... of Jaipur Metro Rail Corporation Ltd., do hereby solemnly affirm and state on the behalf of Bidder including its constituents as under:

1. I/We the Bidder(s) am/ are signing this document after carefully reading the contents.
2. I/We the Bidder(s) also accept all the conditions of the Bid and have signed all the pages in confirmation thereof.
3. I/We hereby declare that I/We have downloaded the Bid document from Jaipur Metro Rail Corporation Ltd. website sppp.rajasthan.gov.in and printed the same. I/we have verified the contents of the printed document from the website and there is no addition, on deletion or no alteration to the contents of the Bid document in case of any discrepancy noticed at the stage i.e.; evaluation of Bids, execution of work or final payment of the contract, the master copy available with the JMRC administration shall be final and binding upon me/us.
4. I/ we declare and certify that I/We have not made any misleading or false representation in the forms, statements and attachments in proof of the qualification requirements.
5. I/we also understand that my/our offer will be evaluated based on the documents/ credentials submitted along with the offer and same shall be binding upon me/us.
6. I/ we certify that I/ we are not blacklisted by Central Government, any State Government or any Government agency or Public sector undertaking (PSU).
7. I/we declare that the information and documents submitted along with the Bid by me/us are correct and I/we are fully responsible for the correctness of the information and documents submitted by us.
8. I/we understand that any of the certificates regarding eligibility criteria submitted by us are found to be forged/false or incorrect at any time during process for evaluation of Bids, it shall lead to forfeiture of Bid EMD besides suspending of business for one year. Further, I /we (insert name of the Bidder) **and all my/our constituents understand that my/our offer shall be summarily rejected.
9. I/we also understand that if any of the certificates submitted by us are found to be false/forged or incorrect at any time the award of the contract, it will lead to termination of the contract, along with forfeiture of EMD and Performance guarantee besides any other action provided in the contract.

DEPONENT

SEAL AND SIGNATURE
OF THE BIDDER
VERIFICATION

I/we above named Bidder do hereby solemnly affirm and verify that the contents of my above affidavit are true and correct. Nothing has been concealed and no part of it is false.

DEPONENT

SEAL AND SIGNATURE
OF THE BIDDER

Place:

Date:

**The contents in italics are only for guidance purpose. Details as appropriate are to be fill in suitably by Bidder.



6.2 Form: B FORM OF BID

Note:

- I. The Appendix forms part of the Bid.
- II. Bidder is required to fill up all the blank spaces in this Form of Bid and Appendix.

Name of Work: **PROCUREMENT OF SALOON DOOR ROLLERS COMPLETE**

To

Director (O&S),
Jaipur Metro Rail Corporation Ltd.,
Admin Building, Train Maintenance Depot,
Bhrigu path, Mansarovar, Jaipur – 302020
Email: dos@jaipurmetrorail.in

1. Having visited the site and examined the General Conditions of Contract as well as Special Conditions of Contract, Specifications, Instructions to Bidders, for the execution of above named works, we the undersigned, offer to execute and complete such works and remedy defects therein in conformity with the said Conditions of Contract, Specifications, and Addenda.
2. We acknowledge that the Appendix forms an integral part of the Bid.
3. We undertake, if our Bid is accepted, to deliver the material within time limit as prescribed in NIB.
4. If our Bid is accepted, we will furnish at our option a Bank Guarantee for Performance as security for the due performance of the Contract. The amount and form of such guarantee or bond will be in accordance with the General Conditions of the Contract and as indicated in the Appendix.
5. We have independently considered the amount as per the General Conditions of Contract as liquidated damages and agree that they represent a fair estimate of the damages likely to be suffered by you in the event of the work not being completed in time.
6. We agree to abide by this Bid for a minimum period of 90 days from the date fixed for receiving the same and it shall remain binding upon us and may be accepted at any time before the expiry of that period or any extended period mutually agreed to.
7. We declare that the submission of this Bid confirms that no agent, middleman or any intermediary has been, or will be engaged to provide any services, or any other item of work related to the award and performance of this Contract. We further confirm and declare that no agency commission or any payment, which may be construed as an agency commission has been, or will be, paid and that the bid price does not include any such amount.
8. We acknowledge the right of the Employer, if he finds to the contrary, to declare our Bid to be non-compliant and if the Contract has been awarded to declare the Contract null and void.
9. We understand that you are not bound to accept the lowest or any bid you may receive.

Signature of Authorized Signatory of Bid

10. If our Bid is accepted we understand that we are to be held solely responsible for the due performance of the Contract.

Dated this.....day of..... 2024

Signature

Name..... in the capacity of

Duly authorized to sign Bids for and on behalf of.....

Address

Date _____

Name _____

Place _____

Address _____

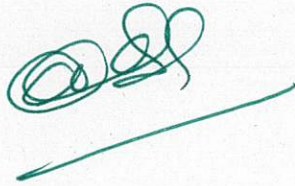

6.3 Form: C Format of Bank Guarantee for Performance Security

On minimum stamp paper value of 0.25% of BG amount

(On any state stamp paper after issue of PO/LOA)

This deed of Guarantee made this day of _____ between Bank of _____ (hereinafter called the "Bank") of the one part, and Jaipur Metro Rail Corporation Limited (hereinafter called "the Employer") of the other part.

Whereas Jaipur Metro Rail Corporation Limited has awarded the contract for "**PROCUREMENT OF SALOON DOOR ROLLERS COMPLETE**" Bid No. JMRC/O&S/RS/2023-24/NIB/026 (here in after called "the contract") to M/s (Name of the Contractor) (here in after called "the Contractor").

AND WHEREAS the Contractor is bound by the said Contract to submit to the Employer a Performance Security for a total amount of Rs. (TO BE FILLED AT THE TIME OF SUBMISSION) (Amount in figures and words).

Now we the Undersigned _____ (Name of the Bank) being fully authorized to sign and to incur obligations for and on behalf of and in the name of _____ (Full name of Bank), hereby declare that the said Bank will guarantee the Employer the full amount of Rs. (TO BE FILLED AT THE TIME OF SUBMISSION) (Amount in figures and Words) as stated above.

After the Contractor has signed the aforementioned Contract with the Employer, the Bank is engaged to pay the Employer, any amount up to and inclusive of the aforementioned full amount upon written order from the Employer to indemnify the Employer for any liability of damage resulting from any defects or shortcomings of the Contractor or the debts he may have incurred to any parties involved in the Works under the Contract mentioned above, whether these defects or shortcomings or debts are actual or estimated or expected. The Bank will deliver the money required by the Employer immediately on demand without delay without reference to the Contractor and without the necessity of a previous notice or of judicial or administrative procedures and without it being necessary to prove to the Bank the liability or damages resulting from any defects or shortcomings or debts of the Contractor. The Bank shall pay to the Employer any money so demanded notwithstanding any dispute/disputes raised by the Contractor in any suit or proceedings pending before any Court, Tribunal or Arbitrator/s relating thereto and the liability under this guarantee shall be absolute and unequivocal.

At any time during the period in which this Guarantee is still valid, if the Employer agrees to grant a time extension to the Contractor or if the Contractor fails to complete the Works within the time of completion as stated in the Contract, or fails to discharge himself of the liability or damages or debts as stated under above para, it is understood that the Bank will extend this Guarantee under the same conditions for the required time on demand by the Employer and at the cost of the Contractor.

The Guarantee hereinbefore contained shall not be affected by any change in the Constitution of the Bank or of the Contractor.



Signature of Authorized Signatory of Bid

The neglect or forbearance of the Employer in enforcement of payment of any moneys, the payment whereof is intended to be hereby secured or the giving of time by the Employer for the payment hereof shall in no way relieve the bank of their liability under this deed.

The expressions "the Employer", "the Bank" and "the Contractor" hereinbefore used shall include their respective successors and assigns.

In witness whereof I/We of the bank have signed and sealed this guarantee on the _____ day of _____ (Month) 2024 being herewith duly authorized.

For and on behalf of the _____ Bank.

Signature of authorized Bank official

Name:

Designation :

I.D. No. :

Stamp/Seal of the Bank:

Signed, sealed and delivered for and on behalf of the Bank by the above named _____

In the presence of:

Witness 1.

Signature

Name

Address

Witness 2.

Signature

Name

Address

- Bank details of JMRC are as below :
 Account Holder Name: Jaipur Metro Rail Corporation
 Account No.: 678605111973, IFSC code: ICIC0006786

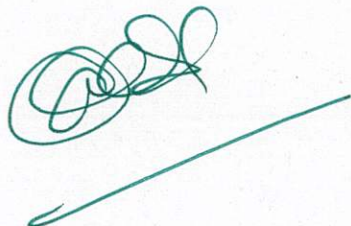

6.4 FORM D FORM OF BANK GUARANTEE FOR BID SECURITY

On minimum stamp paper value of 0.25% of BG amount (On any state stamp paper)

Know all men by these presents that we _____ (Name of Bank) having our registered office at _____ (Address and Name of company) (hereinafter called "the Bank") are bound unto Jaipur Metro Rail Corporation Limited (hereinafter called "the Employer") in the sum of Rs. _____ for which payment will and truly to be made to the said Employer, the Bank binds itself, its successors and assigns by these presents.

Whereas _____ (name of Bidder) (hereinafter called "the Bidder") has submitted its Bid dated _____ for contract for PROCUREMENT OF SALOON DOOR ROLLERS COMPLETE hereinafter called "the Bid".

And whereas the Bidder is required to furnish a bank guarantee for the sum of Rs. _____ (Rupees _____) as Bid security against the Bidder's offer as aforesaid. And whereas _____ (name and address of the bank) have, at the request of the Bidder, agreed to give this guarantee as hereinafter contained.

We further agree as follows:

- a. That the Employer may without affecting this guarantee grant time or other indulgence to or negotiate further with the Bidder in regard to the conditions contained in the said Bid and thereby modify these conditions or add thereto any further conditions as may be mutually agreed upon between the Employer and the Bidder.
- b. That the guarantee herein before contained shall not be affected by any change in the constitution of our Bank or in the constitution of the Bidder.
- c. That any account settled between the Employer and the Bidder shall be conclusive evidence against us of the amount due hereunder and shall not be questioned by us.
- d. That this Guarantee commences from the date hereof and shall remain in force till(Date up to which Guarantee is valid i.e. 120 days from the last date of Bid submission.
- e. That the expression 'the Bidder' and 'the Bank' herein used shall, unless such an interpretation is repugnant to the subject or context, include their respective successors and assigns.

THE CONDITIONS OF THIS OBLIGATION ARE:

- a. If the Bidder withdraws his Bid during the period of Bid validity specified in the Form of Bid, or
- b. If the Bidder having been notified of the acceptance of his Bid by the Employer during the period of Bid validity:
 - i. Fails or refuses to furnish the Performance Security
 - ii. Fails or refuses to enter into a Contract within the time limit.

We undertake to pay to the Employer up to the above amount upon receipt of his first written demand, without the Employer having to substantiate his demand provided that in his demand the Employer will note that the amount claimed by him is due to him owing to

the occurrence of any one or more of the conditions (a) and (b) mentioned above, specifying the occurred condition or conditions.

Signature of the witness	Signature of Authorized of the Bank Official
Name of the Witness	Name of Official	Designation
Address of the Witness	I.D. No.	Stamp/Seal of the Bank

- Bank details of JMRC are as below :
Account Holder Name: Jaipur Metro Rail Corporation
Account No.: 678605111973, IFSC code: ICIC0006786



6.5 Form: E AGREEMENT

6.5.1 This Agreement is made on the _____ day of _____ 2024 Between Director (O&S), JAIPUR METRO RAIL CORPORATION LTD, 4th Floor, Admin Building, Train Maintenance Depot, Bhriгу path Mansarovar Depot, Jaipur- 302020 herein after called "the Employer" of the one part and _____ (Name and Address of Contractor) hereinafter called "the Contractor" of the other part. Whereas the Employer is desirous that (certain Goods and Services should be provided and) certain Works should be executed, viz Contract No. "JMRC/O&S/RS/2023-24/NIB/026" contract for "PROCUREMENT OF SALOON DOOR ROLLERS COMPLETE" of Rail/Metro Corridor of Jaipur MRTS Project hereinafter called "the Works" and has accepted a Bid by the Contractor for the execution and completion of such works (** as well as guarantee of such works) and the remedying of defects therein.

NOW THIS AGREEMENT WITNESSED as follows:

6.5.2 In this Agreement words and expression shall have the same meanings as are respectively assigned to them in the Conditions of Contract hereinafter referred to.

6.5.3 The following documents shall be deemed to form and be read and construed as part of this Agreement, viz:

- (a) Letter of acceptance
- (b) General Conditions of Contract
- (c) Special Conditions of Contract
- (d) Notice Inviting Bid and Scope of Work
- (e) Bill of Quantities
- (f) Form of Bid with Appendix
- (g) Addendums, if any
- (h) Other conditions agreed to and documented as listed below:
 - (i) Bidder's Work Schedule as amended if required.
 - (ii) Statement of deviations (if applicable)
 - (iii) Any other item as applicable

6.5.4 In consideration of the payments to be made by the Employer to the Contractor as hereinafter mentioned, the Contractor hereby covenants with the Employer to execute and complete deliver the works/material by ___** and remedy any defects therein in conformity in all respects with the provisions of the Contract.

The Employer hereby covenants to pay the Contractor in consideration of the execution and completion of the works and the remedying of defects therein, the Contract Price of **Rs(to be filled at the time of agreement) being the sum stated in the letter of acceptance subject to such additions thereto or deductions there from as may be made under the provisions of the Contract at the times and in the manner prescribed by the Contract.

OBLIGATION OF THE CONTRACTOR

6.5.5 The contractor shall ensure full compliance with tax laws of India with regard to this contract and shall be solely responsible for the same. The contractor shall submit copies of acknowledgements evidencing filing of returns every year and shall keep the Employer fully

indemnified against liability of tax, interest, penalty etc. of the contractor in respect thereof, which may arise.

JURISDICTION OF COURT

The Courts at Jaipur/Jaipur shall have the exclusive jurisdiction to try all disputes arising out of this agreement between the parties.

IN WITNESS WHEREOF the parties hereto have caused their respective Common Seals to be hereunto affixed / (or have hereunto set their respective hands and seals) the day and year first above written.

For and on behalf of the Contractor

For and on behalf of the Employer

Signature of the authorized official

Signature of the authorized official

Name of the official

Name of the official

Stamp/Seal of the Contractor

Stamp/Seal of the Employer

SIGNED, SEALED AND DELIVERED

By the said

By the said

Name: _____

Name: _____

on behalf of the Contractor in the presence of:

on behalf of the Employer in the presence of:

Witness _____

Witness _____

Name _____

Name _____

Address _____

Address _____

Note: To be made out by the Employer at the time of finalization of the Form of Agreement.

****** Blanks to be filled by the Employer at the time of finalization of the Form of Agreement.

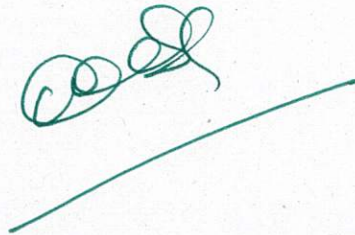

6.6 Form: F Power of Attorney for Signing of Bid

Know all men by these presents, We.....(name of the firm and address of the registered office) do here by irrevocably constitute, nominate, appoint and authorize Mr./Ms.(name)..... Son/daughter/wife of..... and presently residing at....., who is presently employed with us and holding the position of.....as our true and lawful attorney (hereinafter referred to as the "Attorney")to do in our name and on our behalf, all such acts, deeds and things as are necessary or required in connection with or incidental to submission of our Bid no. JMRC/O&S/RS/2023-24/NIB/026 for qualification and submission of our Bid for the works, including but not limited to signing and submission of all Bids, bids and other documents and writings, and other conferences and providing information/ responses to JMRC, representing us in all matters before JMRC, signing and execution of all contracts including the Contract and undertakings consequent to acceptance of our bids, and generally dealing with the JMRC in all matters in connection with or relating to or arising out of our Bid for the said Projects and/or upon award thereof thousand /or till the entering into of the Contracts with JMRC.

AND we hereby agree to ratify and confirm and do hereby ratify and confirm all acts, deeds and things lawfully done or caused to be done by our said Attorney pursuant to and in exercise of the powers conferred by this Power of Attorney and that all acts, deeds and things done by our said Attorney in exercise of the powers hereby conferred shall and shall always be deemed to have been done by us. IN WITNESS WHEREOF WE ,THE ABOVE NAMED PRINCIPAL HAVE EXECUTED THIS POWER OF ATTORNEY ON THISDAY OF.....,2024.

For (Signature)

(Name, Title and Address) Witnesses:

Accepted

.....Signature)
(Name, Title and Address of the Attorney)

(Notarized)

Notes:

The mode of execution of the Power of Attorney should be in accordance with the procedure, if any, laid down by the applicable law and the charter documents of the executants(s) and when it is so required, the same should be under common seal affixed in accordance with the required procedure. Also, wherever required, the Applicant should submit for verification the extract of the charter documents and documents such as a resolution/power of attorney in favors of the person executing this Power of Attorney for the delegation of power hereunder on behalf of the Applicant.

* **Note:** If any Board resolution/Power of attorney in vogue for bidding on behalf of company is also accepted. Copy of same is to be attached.

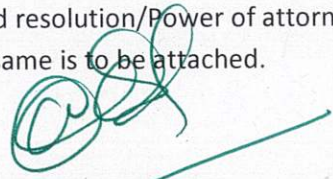

6.7 Form: G Form of Self Declaration

To,

Director (O&S),
Jaipur Metro Rail Corporation Ltd.,
Admin Building, Train Maintenance Depot,
Bhrigu path, Mansarovar, Jaipur – 302020
Email: dos@jaipurmetrorail.in

In response to the NIB Ref. No. _____ dated _____ for {Project Title}, as an Owner/ Partner/ Director/ Auth. Sign. of _____, I/ We hereby declare that presently our Company/ firm _____, at the time of bidding, :-

- a) possess the necessary professional, technical, financial and managerial resources and competence required by the Bidding Document issued by the Procuring Entity;
- b) have fulfilled my/ our obligation to pay such of the taxes payable to the Union and the State Government or any local authority as specified in the Bidding Document;
- c) is having unblemished record and is not declared ineligible for corrupt & fraudulent practices either indefinitely or for a particular period of time by any State/ Central government/ PSU/ UT.
- d) does not have any previous transgressions with any entity in India or any other country during the last three years
- e) does not have any debarment by any other procuring entity
- f) is not insolvent in receivership, bankrupt or being wound up, not have its affairs administered by a court or a judicial officer, not have its business activities suspended and is not the subject of legal proceedings for any of the foregoing reasons;
- g) does not have, and our directors and officers not have been convicted of any criminal offence related to their professional conduct or the making of false statements or misrepresentations as to their qualifications to enter into a procurement contract within a period of three years preceding the commencement of the procurement process, or not have been otherwise disqualified pursuant to debarment proceedings;
- h) Does not have a conflict of interest as mentioned in the bidding document which materially affects the fair competition.
- i) Will comply with the code of integrity as specified in the bidding document.

If this declaration is found to be incorrect then without prejudice to any other action that may be taken as per the provisions of the applicable Act and Rules thereto prescribed by GoR, my/ our security may be forfeited in full and our bid, to the extent accepted, may be cancelled.

Thanking you,

Name of the Bidder: -

Authorized Signatory: - Seal of the Organization: -

Date: _____

Place: _____

6.8 Form: H Compliance with the Code of Integrity and No Conflict of Interest

Any person participating in a procurement process shall -

- (a) Not offer any bribe, reward or gift or any material benefit either directly or indirectly in exchange for an unfair advantage in procurement process or to otherwise influence the procurement process;
- (b) Not misrepresent or omit that misleads or attempts to mislead so as to obtain a financial or other benefit or avoid an obligation;
- (c) Not indulge in any collusion, Bid rigging or anti-competitive behavior to impair the transparency, fairness and progress of the procurement process;
- (d) Not misuse any information shared between the procuring Entity and the Bidders with an intent to gain unfair advantage in the procurement process;
- (e) Not indulge in any coercion including impairing or harming or threatening to do the same, directly or indirectly, to any party or to its property to influence the procurement process;
- (f) Not obstruct any investigation or audit of a procurement process;
- (g) Disclose conflict of interest, if any; and
- (h) Disclose any previous transgressions with any Entity in India or any other country during the last three years or any debarment by any other procuring entity.

Conflict of Interest:-

The Bidder participating in a bidding process must not have a Conflict of Interest. A Conflict of Interest is considered to be a situation in which a party has interests that could improperly influence that party's performance of official duties or responsibilities, contractual obligations, or compliance with applicable laws and regulations.

- i. A Bidder may be considered to be in Conflict of Interest with one or more parties in abiding process if, including but not limited to:
 - a. have controlling partners/ shareholders in common; or
 - b. receive or have received any direct or indirect subsidy from any of them; or
 - c. have the same legal representative for purposes of the Bid; or
 - d. have a relationship with each other, directly or through common third parties, that puts them in a position to have access to information about or influence on the Bid of another Bidder, or influence the decisions of the Procuring Entity regarding the bidding process; or
 - e. The Bidder participates in more than one Bid in a bidding process. Participation by a Bidder in more than one Bid will result in the disqualification of all Bids in which the Bidder is involved. However, this does not limit the inclusion of the same subcontractor, not otherwise participating as a Bidder, in more than one Bid; or
 - f. the Bidder or any of its affiliates participated as a consultant in the preparation of the design or technical specifications of the Goods, Works or Services that are the subject of the Bid; or
 - g. Bidder or any of its affiliates has been hired (or is proposed to be hired) by the Procuring Entity as engineer-in-charge/consultant for the contract.

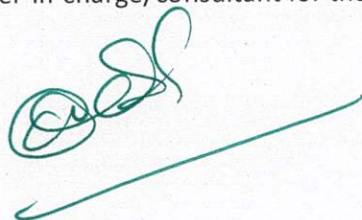

6.9 Form: I GENERAL INFORMATION

Notes:

- I. Attach an attested photocopy of Certificate of Registration and ownership as well as of Constitution and legal status.*
- II. In case of Joint Venture / Consortium, attach an attested photocopy of Agreement indicating inter alia distribution of responsibilities among the members / constituents.*

1. Bidder Company details (in case of consortium, details of Lead Partner)

- (a) Name of Bidder Company:
- (b) Address of the corporate headquarters and its branch office(s), if any, in India:

- (c) Date of incorporation and/ or commencement of business:

2. Particulars of the Authorised Signatory of the Applicant:

- (a) Name:
- (b) Designation:
- (c) Address:
- (d) Phone Number:
- (e) Fax Number:

3. PAN Number (attach photocopy):

4. GST Reg. No (attach copy of the registration certificate):

5. Bank Account Details (for purpose of receiving payment from JMRC) :

- a. Name of the Account Holder:
- b. Name of the Bank:
- c. Branch Address:
- d. 9-digit MICR Code:
- e. Account type (SB, Current, Cash Credit A/c, etc.):
- f. Account No:
- g. IFSC Code:

(Yes/No)

6. In the case of a consortium:

a. Names of participating members / constituents

(a)

(b)

(c)

b. Address, telephone, Tele-fax and email of each members / constituent.

Registered Office

Office for correspondence

(a) _____

(b) _____

(c) _____

c. Distribution of responsibilities among partners / constituents. (Among other details, specify the sub-items of works for which each of the partners / constituents would be responsible).

d. Date and place of joint Venture/ Consortium Agreement.

e. Names and Addresses of Bankers to the Joint Venture/ Consortium

f. Names and Addresses of Associated Companies to be involved in the Project and whether Parent / subsidiary/ others.

g. If the company is subsidiary, what involvement, if any, will the Parent Company have in the Project?



6.10 Form: J BANK DETAILS FOR E-PAYMENT

Beneficiary name :

Beneficiary Address :

Line-1:	
Line-2:	
District/City:	State:
Pin Code:	Tele/Fax:
Mobile alert:	

Bank Details:

Bank Name:	
Branch Name and Address:	
Beneficiary A/C No.	Beneficiary A/C Type (Saving/Current):
Beneficiary A/c Name:	
Nine - Digit branch MICR Code:	
IFSC Code of the branch:	

Stamp & Signature of Authorized Signatory



6.11 Form: K GRIEVANCE REDRESSAL DURING PROCUREMENT PROCESS

The designation and address of the First Appellate Authority is MD, JAIPUR METRO RAIL CORPORATION, JAIPUR.

The designation and address of the Second Appellate Authority is Chairman, JAIPUR METRO RAIL CORPORATION, JAIPUR.

(1) Filing an appeal

If any Bidder or prospective bidder is aggrieved that any decision, action or omission of the Procuring Entity is in contravention to the provisions of the Act or the Rules or the Guidelines issued there under, he may file an appeal to First Appellate Authority, as specified in the Bidding Document within a period of ten days from the date of such decision or action, omission, as the case may be, clearly giving the specific ground or grounds on which he feels aggrieved:

Provided that after the declaration of a Bidder as successful the appeal may be filed only by a Bidder who has participated in procurement proceedings:

Provided further that in case a Procuring Entity evaluates the Technical Bids before the opening of the Financial Bids, an appeal related to the matter of Financial Bids may be filed only by a Bidder whose Technical Bid is found to be acceptable.

- (2) The officer to whom an appeal is filed under Para (1) shall deal with the appeal as expeditiously as possible and shall endeavor to dispose it within thirty days from the date of the appeal.
- (3) If the officer designated under para (1) fails to dispose of the appeal filed within the period specified in para (2), or if the Bidder or prospective bidder or the Procuring Entity is aggrieved by the order passed by the First Appellate Authority, the Bidder or prospective bidder or the Procuring Entity, as the case may be, may file a second appeal to Second Appellate Authority specified in the Bidding Document in this behalf within fifteen days from the expiry of the period specified in para (2) or of the date of receipt of the order passed by the First Appellate Authority, as the case may be.

(4) Appeal not to be in certain cases

No appeal shall lie against any decision of the Procuring Entity relating to the following matters, namely:-

- (a) determination of need of procurement;
- (b) provisions limiting participation of Bidders in the Bid process;
- (c) the decision of whether or not to enter into negotiations;
- (d) cancellation of a procurement process;
- (e) Applicability of the provisions of confidentiality.

(5) Form of Appeal

- (a) An appeal under para (1) or (3) above shall be in the annexed Form along with as many copies as there are respondents in the appeal.

- (b) Every appeal shall be accompanied by an order appealed against, if any, affidavit verifying the facts stated in the appeal and proof of payment of fee.
- (c) Every appeal may be presented to First Appellate Authority or Second Appellate Authority, as the case may be, in person or through registered post or authorized representative.

(6) Fee for filing appeal

- (a) Fee for first appeal shall be rupees two thousand five hundred and for second appeal shall be rupees ten thousand, which shall be non-refundable.
- (b) The fee shall be paid in the form of bank demand draft or banker's cheque of a Scheduled Bank in India payable in the name of Appellate Authority concerned.

(7) Procedure for disposal of appeal

- (a) The First Appellate Authority or Second Appellate Authority, as the case may be, upon filing of appeal, shall issue notice accompanied by copy of appeal, affidavit and documents, if any, to the respondents and fix date of hearing.
- (b) On the date fixed for hearing, the First Appellate Authority or Second Appellate Authority, as the case may be, shall,-
 - (i) Hear all the parties to appeal present before him; and
 - (ii) Peruse or inspect documents, relevant records or copies thereof relating to the matter.
- (c) After hearing the parties, perusal or inspection of documents and relevant records or copies thereof relating to the matter, the Appellate Authority concerned shall pass an order in writing and provide the copy of order to the parties to appeal free of cost.
- (d) The order passed under sub-clause (c) above shall also be placed on the State Public Procurement Portal

Memorandum of Appeal under the Rajasthan Transparency in Public Procurement Act, 2012

Appeal No. of

Before the (First / Second Appellate Authority)

1. Particulars of appellant:

- (i) Name of the appellant:
- (ii) Official address, if any:
- (iii) Residential address:

2. Name and address of the respondent(s):

- (i)
- (ii)
- (iii)

3. Number and date of the order appealed against and name and designation of the officer / authority who



passed the order (enclose copy), or a statement of a decision, action or omission of the Procuring Entity in contravention to the provisions of the Act by which the appellant is aggrieved:

4. If the Appellant proposes to be represented by a representative, the name and postal address of the representative:

5. Number of affidavits and documents enclosed with the appeal:

6. Grounds of appeal:

.....
.....(Supported by an affidavit)

7. Prayer:

.....

Place

Date

Signature

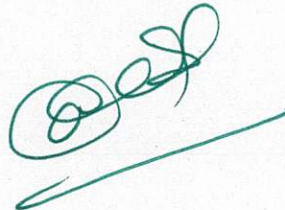

7 Financial Bid:

BOQ (Bill Of Quantity)

Validate Print Help **BoQ**

Tender Inviting Authority: DIRECTOR (O &S)

Name of Work: Procurement of Saloon Door Rollers Complete

Contract No: JMRC/O&S/RS/2023-24/NIB/026

Name of the Bidder/ Bidding Firm / Company :	
--	--

PRICE SCHEDULE

(DOMESTIC TENDERS - RATES ARE TO GIVEN IN RUPEES (INR) ONLY)

1. This BOQ template must not be modified/replaced by the bidder and the same should be uploaded after filling the relevant columns, else the bidder is liable to be rejected for this tender. Bidders are allowed to enter the Bidder Name and Values only
2. The rates quoted above shall be inclusive of all taxes, Freight charges, packing charges etc; no other charges shall be paid by JMRC. GST will be paid at rate applicable at the time of billing.)
3. Fill applicable GST rate without % age sign.

NUMBER #	TEXT #	NUMBER #	TEXT #	NUMBER #	NUMBER	NUMBER #	NUMBER #	TEXT #
Sl. No.	Item Description	Quantity	Units	BASIC RATE In Figures To be entered by the Bidder In (INR)	GST Rate Applicable(%age)	TOTAL AMOUNT Without Taxes(INR)	TOTAL AMOUNT With Taxes (INR)	TOTAL AMOUNT In Words
1	Particulars:							
1.01	Roller Complete Centric (KB Part no: 3T410101R07) or Equivalent	640.00	Nos			0.00	0.00	INR Zero Only
1.02	Roller Complete Eccentric (KB Part no: 3T410101R08) or Equivalent	640.00	Nos			0.00	0.00	INR Zero Only
Total in Figures						0.00	0.00	INR Zero Only
Quoted Rate in Words						INR Zero Only		

(Handwritten Signature)
 12/8/24